



## *Service Manual*

**Lexmark™ T650, T650n, T652dn,  
T654dn & T656dne Printer**

---

**4062-XXX**

- ***Table of contents***
- ***Start diagnostics***
- ***Safety and notices***
- ***Trademarks***
- ***Index***

**LEXMARK™**

*Lexmark and Lexmark with diamond design are trademarks of Lexmark International, Inc., registered in the United States and/or other countries.*

**Edition: September 17, 2009**

**The following paragraph does not apply to any country where such provisions are inconsistent with local law:** LEXMARK INTERNATIONAL, INC. PROVIDES THIS PUBLICATION "AS IS" WITHOUT WARRANTY OF ANY KIND, EITHER EXPRESS OR IMPLIED, INCLUDING, BUT NOT LIMITED TO, THE IMPLIED WARRANTIES OF MERCHANTABILITY OR FITNESS FOR A PARTICULAR PURPOSE. Some states do not allow disclaimer of express or implied warranties in certain transactions; therefore, this statement may not apply to you.

This publication could include technical inaccuracies or typographical errors. Changes are periodically made to the information herein; these changes will be incorporated in later editions. Improvements or changes in the products or the programs described may be made at any time.

Comments may be addressed to Lexmark International, Inc., Department D22X/002-1, 740 West New Circle Road, Lexington, Kentucky 40550, U.S.A or e-mail at [ServiceInfoAndTraining@Lexmark.com](mailto:ServiceInfoAndTraining@Lexmark.com). Lexmark may use or distribute any of the information you supply in any way it believes appropriate without incurring any obligation to you.

References in this publication to products, programs, or services do not imply that the manufacturer intends to make these available in all countries in which it operates. Any reference to a product, program, or service is not intended to state or imply that only that product, program, or service may be used. Any functionally equivalent product, program, or service that does not infringe any existing intellectual property right may be used instead. Evaluation and verification of operation in conjunction with other products, programs, or services, except those expressly designated by the manufacturer, are the user's responsibility.

Lexmark, Lexmark with diamond design, and MarkNet are trademarks of Lexmark International, Inc., registered in the United States and/or other countries.

PCL® is a registered trademark of the Hewlett-Packard Company.

All other trademarks are the property of their respective owners.

© 2008 Lexmark International, Inc.  
**All rights reserved.**

#### **UNITED STATES GOVERNMENT RIGHTS**

This software and any accompanying documentation provided under this agreement are commercial computer software and documentation developed exclusively at private expense.

# Table of contents

<b>Table of contents</b> .....	<b>iii</b>
<b>Notices and safety information</b> .....	<b>xv</b>
Laser notice .....	xv
Lithium warning .....	ii-xxi
Safety information .....	xxi
<b>Preface</b> .....	<b>xxiv</b>
Conventions .....	xxiv
<b>General information</b> .....	<b>1-1</b>
Maintenance approach .....	1-1
Options .....	1-2
Available internal options .....	1-2
Media handling options .....	1-2
Printer configurations .....	1-3
Basic model .....	1-3
Fully configured model .....	1-4
Supported paper sizes, types, and weights .....	1-6
Paper sizes supported by the printer .....	1-6
Paper types and weights supported by the printer .....	1-7
Paper types and weights supported by the output bins .....	1-7
Tools required .....	1-8
Acronyms .....	1-9
<b>Diagnostic information</b> .....	<b>2-1</b>
Start .....	2-1
Confirm the installation status .....	2-2
Power-on Reset sequence .....	2-2
Entering Diagnostics mode .....	2-2
User attendance messages .....	2-3
Error code table 1 .....	2-14
Service checks .....	2-126
Sensor (input) service check .....	2-126
Sensor (fuser output) service check .....	2-126
Sensor (narrow media) service check .....	2-127
Sensor (duplex input) service check .....	2-127
Sensor (duplex input) service check (external duplex only) .....	2-128
Sensor (duplex exit) service check (external duplex only) .....	2-128
Sensor (pass through) service check .....	2-129
Sensor (envelope feeder empty) service check .....	2-129
Sensor (input) late jam service check .....	2-129
Sensor (input) lingering jam service check .....	2-132
Sensor (input) early jam service check .....	2-133
Sensor (input) static jam service check .....	2-135
Sensor (fuser output) late jam service check .....	2-135
Sensor (fuser output) lingering jam service check .....	2-137
Sensor (fuser output) static jam service check .....	2-138
Sensor (narrow media) late jam service check .....	2-139
Sensor (narrow media) static jam service check .....	2-140
Sensor (duplex input) late jam service check .....	2-141
Sensor (duplex input) lingering jam service check .....	2-142
Sensor (duplex input) static jam service check .....	2-144
Sensor (pass through) late jam service check .....	2-145

Sensor (pass through) lingering jam service check .....	2-146
Sensor (pass through) static jam service check .....	2-147
Sensor (stapler pass through) late jam service check .....	2-148
Sensor (stapler pass through) lingering jam service check .....	2-149
Sensor (stapler pass through) static jam service check .....	2-149
Sensor (output pass through) late jam service check .....	2-150
Sensor (output pass through) lingering jam service check .....	2-151
Sensor (output pass through) static jam service check .....	2-152
Sensor (mailbox empty) late jam service check .....	2-153
Sensor (mailbox empty) lingering jam service check .....	2-154
Sensor (mailbox empty) static jam service check .....	2-154
Sensor (toner empty) service check .....	2-155
NVRAM mismatch failure (950.00 through 950.29) service check .....	2-155
.....	2-156
<b>Image quality trouble</b> .....	2-157
<b>Printer Related Troubleshooting</b> .....	2-157
Image quality symptoms .....	2-157
<b>Image Quality</b> .....	2-158
Faint print (Low contrast) .....	2-158
Blank print (no print) .....	2-160
Solid black .....	2-162
Vertical lines and bands (process direction) .....	2-163
Horizontal white stripes or bands (side to side direction) .....	2-164
Vertical stripes (process direction) .....	2-165
Horizontal stripes (side to side direction) .....	2-166
Partial lack .....	2-168
Spots .....	2-169
After image .....	2-171
Background (fog) .....	2-172
Skew .....	2-173
Media damage .....	2-174
No fuse .....	2-176
<b>Network service check</b> .....	2-177
<b>Diagnostic aids</b> .....	<b>3-1</b>
<b>Understanding the printer control panel (models T650, T652, and T654)</b> .....	<b>3-1</b>
<b>Accessing service menus (models T650, T652, and T654)</b> .....	<b>3-2</b>
<b>Diagnostics mode (models T650, T652, and T654)</b> .....	<b>3-3</b>
<b>Entering Diagnostics mode (models T650, T652, and T654)</b> .....	<b>3-3</b>
<b>Available tests</b> .....	<b>3-3</b>
<b>Exiting Diagnostics mode (models T650, T652, and T654)</b> .....	<b>3-5</b>
<b>REGISTRATION</b> .....	<b>3-5</b>
Quick Test .....	3-6
<b>PRINT TESTS</b> .....	<b>3-7</b>
Input source tests .....	3-7
Print quality pages (Prt Quality Pgs) .....	3-7
<b>HARDWARE TESTS</b> .....	<b>3-8</b>
Panel Test .....	3-8
Button Test .....	3-8
DRAM Test .....	3-8
USB HS Test Mode .....	3-9
RFID Option Test .....	3-10
<b>DUPLEX TESTS</b> .....	<b>3-12</b>
Quick Test (duplex) .....	3-12
Top Margin (duplex) .....	3-13
Sensor Test (duplex) .....	3-13
Motor Test (duplex) .....	3-14
Duplex Feed 1 .....	3-14
Duplex Feed 2 .....	3-14



<b>INPUT TRAY TESTS</b> .....	<b>3-14</b>
Feed Tests (input tray) .....	3-15
Sensor Test (input tray) .....	3-15
<b>OUTPUT BIN TESTS</b> .....	<b>3-15</b>
Feed Tests (output bins) .....	3-15
Feed To All Bins .....	3-16
Sensor Test (standard output bin) .....	3-16
Sensor Test (Output Expander) .....	3-17
Sensor Test (high capacity output stacker) .....	3-17
Sensor Tests (5-bin mailbox) .....	3-18
Deflector Test .....	3-18
<b>StapleSmart FINISHER TESTS</b> .....	<b>3-18</b>
Staple Test .....	3-18
Feed Tests (finisher) .....	3-18
Sensor Test (finisher) .....	3-18
<b>BASE SENSOR TEST</b> .....	<b>3-19</b>
<b>PRINTER SETUP</b> .....	<b>3-19</b>
Defaults .....	3-19
Printed Page Count .....	3-19
Perm Page Count (permanent page count) .....	3-20
Serial Number .....	3-20
Engine Setting 1 through 16 .....	3-20
Model Name .....	3-20
Configuration ID .....	3-20
Edge to Edge .....	3-21
<b>EP SETUP</b> .....	<b>3-21</b>
EP Defaults .....	3-21
Fuser Temperature (Fuser Temp) .....	3-21
Fuser Page Count .....	3-21
Warm Up Time .....	3-21
Transfer .....	3-21
Print Contrast .....	3-22
Charge Roll .....	3-22
Gap Adjust .....	3-22
Auto Dark Adj .....	3-22
<b>REPORTS</b> .....	<b>3-23</b>
<b>EVENT LOG</b> .....	<b>3-23</b>
Display Log .....	3-23
Print Log .....	3-23
Clear Log .....	3-24
<b>EXIT DIAGNOSTICS (models T650, T652, and T654)</b> .....	<b>3-24</b>
<b>Configuration menu (CONFIG MENU) (models T650, T652, and T654)</b> .....	<b>3-25</b>
<b>Entering Configuration Menu (models T650, T652, and T654)</b> .....	<b>3-25</b>
<b>Available menus</b> .....	<b>3-25</b>
<b>Maintenance page count (Maint Cnt Value)</b> .....	<b>3-25</b>
<b>Maintenance page counter reset (Reset Cnt)</b> .....	<b>3-26</b>
<b>Print quality pages (Prt Quality Pgs)</b> .....	<b>3-26</b>
<b>Reports</b> .....	<b>3-26</b>
<b>SIZE SENSING</b> .....	<b>3-27</b>
<b>Panel Menus</b> .....	<b>3-27</b>
<b>PPDS Emulation</b> .....	<b>3-27</b>
<b>Demo Mode</b> .....	<b>3-27</b>
<b>Factory Defaults</b> .....	<b>3-28</b>
<b>LES Applications</b> .....	<b>3-28</b>
<b>Energy Conserve</b> .....	<b>3-28</b>
<b>Paper Prompts</b> .....	<b>3-28</b>
<b>Env Prompts</b> .....	<b>3-28</b>
<b>Action for Prompts</b> .....	<b>3-28</b>
<b>Font Sharpening</b> .....	<b>3-28</b>

Wiper Messages .....	3-28
Clear Custom Status .....	3-28
Best Speed .....	3-29
Exit Config Menu (models T650, T652, and T654) .....	3-29
Understanding the printer control panel (model T656) .....	3-29
Accessing service menus (model T656) .....	3-30
Diagnostics Menu (model T656) .....	3-31
Entering Diagnostics Menu (model T656) .....	3-31
Available tests .....	3-31
Registration (printer) .....	3-33
Quick Test .....	3-34
<b>PRINT TESTS .....</b>	<b>3-35</b>
Input source tests .....	3-35
Printing Quality Pages .....	3-35
<b>HARDWARE TESTS .....</b>	<b>3-36</b>
Panel Test .....	3-36
Button Test .....	3-36
DRAM Test .....	3-37
USB HS Test Mode .....	3-37
<b>DUPLEX TESTS .....</b>	<b>3-38</b>
Quick Test (duplex) .....	3-38
Top Margin (duplex) .....	3-38
Left Margin (duplex) .....	3-39
Sensor Test (duplex) .....	3-39
Motor Test (duplex) .....	3-39
Duplex Feed 1 .....	3-40
Duplex Feed 2 .....	3-40
<b>INPUT TRAY TESTS .....</b>	<b>3-40</b>
Feed Tests (input tray) .....	3-40
Sensor Test (input tray) .....	3-41
<b>OUTPUT BIN TESTS .....</b>	<b>3-41</b>
Feed Tests (output bins) .....	3-41
Sensor Test (standard output bin) .....	3-41
<b>BASE SENSOR TEST .....</b>	<b>3-42</b>
<b>DEVICE TESTS .....</b>	<b>3-43</b>
Quick Disk Test .....	3-43
Disk Test/Clean .....	3-43
<b>PRINTER SETUP .....</b>	<b>3-44</b>
Defaults .....	3-44
Printed Page Count .....	3-44
Permanent Page Count .....	3-44
Serial Number .....	3-44
Engine Settings 1 through 16 .....	3-44
Model Name .....	3-44
Configuration ID .....	3-45
Edge to Edge .....	3-45
<b>EP SETUP .....</b>	<b>3-45</b>
EP Defaults .....	3-46
Fuser Temperature (Fuser Temp) .....	3-46
Fuser Page Count .....	3-46
Warm Up Time .....	3-46
Transfer .....	3-46
Print Contrast .....	3-46
Charge Roll .....	3-46
Gap Adjust .....	3-47
Auto Dark Adjust .....	3-47
<b>REPORTS .....</b>	<b>3-47</b>
Menu Settings Page .....	3-47
<b>EVENT LOG .....</b>	<b>3-47</b>

Display Log .....	3-47
Print Log .....	3-48
Clear Log .....	3-48
<b>Configuration menu (CONFIG MENU) (model T656) .....</b>	<b>3-49</b>
<b>Entering Configuration Menu (model T656) .....</b>	<b>3-49</b>
<b>Available menus .....</b>	<b>3-49</b>
<b>Maintenance Counter Value .....</b>	<b>3-49</b>
<b>Reset Maintenance Counter .....</b>	<b>3-50</b>
<b>Print Quality Pages .....</b>	<b>3-51</b>
<b>Reports .....</b>	<b>3-51</b>
Menu Settings Page .....	3-51
Event Log .....	3-51
<b>SIZE SENSING .....</b>	<b>3-52</b>
<b>Panel Menus .....</b>	<b>3-52</b>
<b>PPDS Emulation .....</b>	<b>3-52</b>
<b>Factory Defaults .....</b>	<b>3-54</b>
<b>Energy Conserve .....</b>	<b>3-54</b>
<b>Paper Prompts .....</b>	<b>3-55</b>
<b>Envelope Prompts .....</b>	<b>3-55</b>
<b>Action for Prompts .....</b>	<b>3-55</b>
<b>Jobs On Disk .....</b>	<b>3-55</b>
<b>Disk Encryption .....</b>	<b>3-56</b>
<b>Wipe Disk .....</b>	<b>3-57</b>
<b>Font Sharpening .....</b>	<b>3-57</b>
<b>Require Standby .....</b>	<b>3-57</b>
<b>LES Applications .....</b>	<b>3-58</b>
<b>Key Repeat Initial Delay .....</b>	<b>3-58</b>
<b>Key Repeat Rate .....</b>	<b>3-58</b>
<b>Wiper Message .....</b>	<b>3-58</b>
<b>Clear Custom Status .....</b>	<b>3-58</b>
<b>USB speed .....</b>	<b>3-59</b>
<b>Exit Configuration Menu (model T656) .....</b>	<b>3-59</b>
<b>Printer overview .....</b>	<b>3-60</b>
Basic model .....	3-60
<b>Printer theory .....</b>	<b>3-61</b>
<b>Model T650 with duplex, paper path, rolls, and sensors .....</b>	<b>3-61</b>
<b>Models T652 and T654 paper path rolls and sensors .....</b>	<b>3-62</b>
<b>Functions of main components .....</b>	<b>3-62</b>
Media tray assembly .....	3-62
Rear media guide .....	3-62
Side guide .....	3-63
Wear strips .....	3-63
<b>Media tray assembly .....</b>	<b>3-63</b>
Detection of media size .....	3-63
Pick arm assembly .....	3-64
Switch (media size) .....	3-65
Sensor (media empty) .....	3-65
Sensor (media low) .....	3-65
<b>Multi-purpose feeder (MPF) .....</b>	<b>3-65</b>
MPF feed roll .....	3-65
MPF pick solenoid .....	3-65
Sensor (MPF media empty) .....	3-65
<b>Supported paper sizes, types, and weights .....</b>	<b>3-66</b>
Paper sizes supported by the printer .....	3-66
<b>Registration .....</b>	<b>3-67</b>
Sensor (input) .....	3-67
Aligner assembly .....	3-67
<b>Transfer .....</b>	<b>3-68</b>
Transfer roll assembly .....	3-68

<b>Polygon printhead assembly</b> .....	<b>3-69</b>
<b>Oscillating printhead assembly</b> .....	<b>3-71</b>
<b>Fuser</b> .....	<b>3-72</b>
<b>Fuser components</b> .....	<b>3-72</b>
Heat roll .....	3-73
Pressure roll .....	3-73
Heater lamp .....	3-73
Thermal cutoff .....	3-73
Thermistor .....	3-73
Sensor (fuser output) .....	3-73
Sensor (narrow media) .....	3-73
<b>Fuser unit assembly (type 1 and type 2)</b> .....	<b>3-73</b>
Type 1 fuser unit assembly .....	3-73
Type 2 fuser unit assembly .....	3-74
<b>Exit</b> .....	<b>3-74</b>
Sensor (standard bin full) .....	3-74
<b>Drive</b> .....	<b>3-75</b>
Main drive motor assembly .....	3-75
Redrive motor assembly .....	3-75
<b>Electrical components and controller</b> .....	<b>3-76</b>
Switch (printer front door interlock) .....	3-76
Main cooling fan .....	3-76
Print cartridge cooling fan .....	3-76
Duplex cooling fan .....	3-76
LVPS card assembly .....	3-76
HVPS card assembly .....	3-76
System card assembly .....	3-77
<b>Control</b> .....	<b>3-77</b>
<b>Printhead control</b> .....	<b>3-77</b>
Rotation of printhead motor .....	3-77
Determination of printhead ready .....	3-77
Printhead reference value .....	3-77
<b>Fuser control</b> .....	<b>3-77</b>
Fuser control method .....	3-77
Fuser lamp on/off control .....	3-77
Fuser warm-up .....	3-78
<b>Xerographic and print cartridge components</b> .....	<b>3-78</b>
Charge .....	3-79
Exposure .....	3-79
Development .....	3-80
Transfer .....	3-81
Cleaning .....	3-82
Auto density sensing .....	3-83
<b>High Capacity Input Tray (HCIT) tray assembly</b> .....	<b>3-84</b>
<b>250-sheet/550-sheet tray assembly</b> .....	<b>3-85</b>
Media size sensing .....	3-85
Media level sensing .....	3-86
Pick arm assembly .....	3-86
Switch (media size) .....	3-87
Sensor (media empty) .....	3-87
Sensor (media low) .....	3-87
Sensor (pass-thru) .....	3-87
Media transport path .....	3-89
<b>Model T650 paper path, rolls, and sensors</b> .....	<b>3-89</b>
<b>Models T652 and T654 paper path, rolls, and sensors</b> .....	<b>3-90</b>
Functions of main components .....	3-90
Media tray assembly .....	3-90
Rear media guide .....	3-90
Side guide .....	3-90

Wear strips	3-91
<b>Media tray assembly</b>	<b>3-91</b>
Detection of media size	3-91
Pick arm assembly	3-91
Switch (media size)	3-91
Sensor (media empty)	3-91
Sensor (media low)	3-92
<b>Duplex</b>	<b>3-93</b>
Layout of media transport path	3-93
<b>Model T650 duplex paper path</b>	<b>3-93</b>
<b>Models T652 and T654 duplex paper path</b>	<b>3-94</b>
Functions of main components	3-94
Sensor (duplex input)	3-94
Duplex drive motor assembly	3-95
<b>Understanding jam numbers and locations</b>	<b>3-96</b>
<b>200 and 201 paper jams</b>	<b>3-96</b>
<b>202 and 203 paper jams</b>	<b>3-97</b>
<b>230 paper jam</b>	<b>3-98</b>
Rear paper jams	3-98
Front paper jams	3-99
<b>231-239 paper jams (optional external duplex unit)</b>	<b>3-100</b>
Rear paper jams	3-100
Front paper jams	3-100
<b>241–245 paper jams</b>	<b>3-101</b>
<b>250 paper jam</b>	<b>3-102</b>
<b>260 paper jam</b>	<b>3-103</b>
<b>271–279 paper jams</b>	<b>3-103</b>
<b>280 paper jam</b>	<b>3-104</b>
<b>281 paper jam</b>	<b>3-105</b>
<b>282 paper jam</b>	<b>3-105</b>
<b>283 staple jam</b>	<b>3-106</b>
<b>Security Reset Jumper</b>	<b>3-108</b>
Security Reset Jumper	3-108
<b>Repair Information</b>	<b>4-1</b>
<b>Handling ESD-sensitive parts</b>	<b>4-1</b>
<b>Adjustments</b>	<b>4-2</b>
<b>Polygon and Oscillating printhead mechanical registration adjustment</b>	<b>4-2</b>
<b>Oscillating printhead assembly electronic adjustment</b>	<b>4-3</b>
Alignment assembly adjustment	4-4
Fuser solenoid adjustment	4-6
Gap adjustment	4-6
<b>Removals</b>	<b>4-7</b>
Replacement note: To replace a removed part, reverse the order of removal unless noted otherwise.	4-7
Access door removal (T650, T652, T654)	4-8
Alignment assembly removal (T650, T652, T654)	4-8
Connection access cover, rear removal (T650, T652, T654)	4-11
Connection bezel assembly, rear removal (T650)	4-11
Connection bezel assembly, rear removal (T652, T654)	4-12
Cover assembly, rear lower removal (T650)	4-13
Cover assembly, rear lower (T652, T654)	4-13
Charge roll assembly removal (T650, T652, T654)	4-14
Door assembly, rear removal (T650, T652, T654)	4-15
Duplex guide assembly, rear removal (T652, T654)	4-15
Duplex assembly removal (T652, T654)	4-16
Duplex cooling fan removal (T652, T654)	4-18
Duplex drive motor assembly removal (T652, T654)	4-19
Duplex input sensor assembly removal (T652, T654)	4-20

Duplex guide assembly, front removal (T652, T654)	4-21
Fuser access door assembly removal (T650, T652, T654)	4-22
Fuser drive release linkage removal (T650, T652, T654)	4-23
Fuser unit assembly removal (T650, T652, T654)	4-23
Fuser wiper cover assembly removal (T650, T652, T654)	4-24
HVPS card assembly removal (T650, T652, T654)	4-24
Inner deflector removal (T650, T652, T654)	4-25
Laser cover removal (T650, T652, T654)	4-27
LCD screen bezel removal (T650, T652, T654)	4-28
LVPS card assembly removal (T650)	4-29
LVPS card assembly removal (T652, T654)	4-31
Main cooling fan removal (T650, T652, T654)	4-32
Main drive motor assembly removal (T650, T652, T654)	4-34
Media out actuator removal (T650, T652, T654)	4-35
Media support removal (T650, T652, T654)	4-36
Media turn guide removal (T650, T652, T654)	4-36
MPF cam gear removal (T650, T652, T654)	4-37
MPF lift plate assembly removal (T650, T652, T654)	4-37
MPF media out actuator removal (T650, T652, T654)	4-38
MPF pick roll assembly removal (T650, T652, T654)	4-38
MPF pick solenoid assembly removal (T650, T652, T654)	4-39
MPF tray door assembly removal (T650, T652, T654)	4-41
Operator panel latch assembly removal (T650, T652, T654)	4-43
Operator panel door assembly removal (T650, T652, T654)	4-44
Operator panel hinge assembly, left removal (T650, T652, T654)	4-45
Operator panel hinge assembly, right removal (T650, T652, T654)	4-47
Operator panel door assembly removal (models X651, X652, X654, and X656)	4-49
Operator panel cover latch assembly removal (models X651, X652, X654, and X656)	4-52
Option drive shaft removal (T650, T652, T654)	4-52
Output cover assembly removal (T650, T652, T654)	4-54
Pick arm assembly removal (T650, T652, T654)	4-54
Pick roll assembly removal (T650, T652, T654)	4-57
Print cartridge cooling fan removal (T650, T652, T654)	4-57
Print cartridge clamp assembly removal (T650, T652, T654)	4-58
Print cartridge ID connector assembly removal (T650, T652, T654)	4-59
Printhead assembly removal (T650)	4-60
Printhead assembly removal (T652, T654)	4-61
Redrive assembly removal (T650, T652, T654)	4-62
Redrive motor assembly removal (T652, T654)	4-63
Side cover, left removal (T650)	4-65
Side cover, left removal (T652 and T654)	4-66
Side cover, right removal (T650)	4-67
Side cover, right removal (T652, T654)	4-68
Sensor (duplex input) removal (T652, T654)	4-68
Sensor (media level) removal (T650, T652, T654)	4-70
Sensor (media out) removal (T650, T652, T654)	4-70
Sensor (toner empty) removal (T650, T652, T654)	4-71
Sensor (input) removal (T650, T652, T654)	4-71
Sensor shield assembly removal (T650, T652, T654)	4-72
Sensor (standard bin exit) removal (T650, T652, T654)	4-73
Sensor (toner density) removal (T650, T652, T654)	4-73
Standard bin actuator assembly removal (T650, T652, T654)	4-73
Switch (media size) assembly removal (T650, T652, T654)	4-74
System card assembly removal (T650, T652, T654, T656)	4-76
Transfer roll assembly removal (T650, T652, T654)	4-78
Transfer roll bracket assembly, left removal (T650, T652, T654)	4-79
Transfer roll bracket assembly, right removal (T650, T652, T654)	4-80
Transfer deflector removal (T650, T652, T654)	4-80
Tray roller catch assembly removal (T650, T652, T654)	4-81

Option removals .....	4-83
5-bin mailbox rear door assembly removal .....	4-84
5-bin mailbox left outer cover removal .....	4-85
5-bin mailbox left inner cover removal .....	4-85
5-bin mailbox right outer cover removal .....	4-86
5-bin mailbox right inner cover removal .....	4-87
5-bin mailbox top cover removal .....	4-88
5-bin mailbox media bin full actuator removal .....	4-89
5-bin mailbox sensor (pass through) removal .....	4-90
5-bin mailbox sensor (media bin empty) removal .....	4-91
5-bin mailbox controller card assembly removal .....	4-92
5-bin mailbox static brush mylar assembly removal .....	4-93
5-bin mailbox media bin fifth deflector removal .....	4-94
5-bin mailbox media bin first through fourth deflector removal .....	4-95
5-bin mailbox media bin extension assembly removal .....	4-96
5-bin mailbox deflector gate solenoid removal .....	4-96
5-bin mailbox transport solenoid removal .....	4-98
5-bin mailbox sensor (deflector gate HP) removal .....	4-99
250-sheet option tray assembly .....	4-101
250-sheet media tray assembly removal .....	4-101
250-sheet pick arm bracket assembly removal .....	4-102
250-sheet media out actuator removal .....	4-104
250-sheet frame assembly removal .....	4-104
250-sheet controller card assembly removal .....	4-106
550-sheet option tray assembly .....	4-107
550-sheet media tray assembly removal .....	4-107
550-sheet pick arm bracket assembly removal .....	4-108
550-sheet bellcrank recoil spring removal .....	4-109
550-sheet frame assembly removal .....	4-109
550-sheet controller card assembly removal .....	4-111
550-sheet option drive shaft with spring removal .....	4-113
Anti-tip latch assembly removal .....	4-113
High capacity input tray (HCIT) .....	4-114
High capacity input tray (HCIT) media tray assembly removal .....	4-115
High capacity input tray (HCIT) tray cover, front removal .....	4-116
High capacity input tray (HCIT) cover, rear removal .....	4-118
High capacity input tray (HCIT) cover, right removal .....	4-120
High capacity input tray (HCIT) cover, left removal .....	4-122
High capacity input tray (HCIT) anti-tip latch assembly removal .....	4-123
High capacity input tray (HCIT) drawer slide assembly removal .....	4-124
High capacity input tray (HCIT) tray lift drive motor assembly removal .....	4-125
High capacity input tray (HCIT) controller card assembly removal .....	4-126
High capacity input tray (HCIT) media size actuator assembly removal .....	4-127
High capacity input tray (HCIT) pick arm bracket assembly removal .....	4-130
High capacity input tray (HCIT) tray closed latch with spring removal .....	4-132
High capacity stacker rear door assembly removal .....	4-132
High capacity stacker right cover removal .....	4-134
High capacity stacker left cover removal .....	4-135
High capacity stacker media output bin assembly removal .....	4-136
High capacity stacker controller card cover panel removal .....	4-137
High capacity stacker switch (media bin HP) removal .....	4-138
High capacity stacker sensor (media bin full) assembly removal .....	4-139
High capacity stacker sensor (media bin full) bracket assembly removal .....	4-139
High capacity stacker controller card assembly (upper and lower) removal .....	4-140
High capacity stacker right frame removal .....	4-141
High capacity stacker left frame removal .....	4-142
High capacity stacker upper deflector gate removal .....	4-143
High capacity stacker sensor (pass through) removal .....	4-144
High capacity stacker left mounting bracket removal .....	4-146

High capacity stacker sensor (deflector gate HP) removal	4-147
Installing / Removing the RFID UHF option	4-148
Lower interface cable assembly removal	4-156
Media size actuator removal	4-157
Media tray catch spring removal	4-158
Media out actuator removal (models T652 and T654)	4-158
Media size actuator removal	4-159
Media tray catch spring removal	4-159
Media tray roller catch assembly removal	4-159
Output expander rear door assembly removal	4-161
Output expander left outer cover removal	4-161
Output expander left inner cover removal	4-162
Output expander right outer cover removal	4-162
Output expander right inner cover removal	4-163
Output expander media bin latch (left and right) removal	4-163
Output expander media output bin assembly removal	4-164
Output expander media bin full actuator removal	4-164
Output expander sensors (media bin full) assembly removal	4-165
Output expander sensor (media bin full) bracket assembly removal	4-166
Output expander controller card cover panel removal	4-166
Output expander controller card removal	4-168
Output expander sensor (pass through) removal	4-169
Output expander deflector gate removal	4-170
Output expander sensor (deflector gate HP) removal	4-171
SFP stapler assembly rear door assembly removal	4-172
SFP stapler assembly right cover removal	4-172
SFP stapler assembly left cover removal	4-173
SFP stapler assembly top cover removal	4-174
SFP stapler assembly handle cover removal	4-175
SFP stapler assembly LED sensor cover removal	4-176
SFP stapler assembly sensor (finisher bin media present) removal	4-177
SFP stapler assembly standard output bin LED and LED clear lens removal	4-178
SFP stapler assembly tamper drive belt removal	4-179
SFP stapler assembly tamper drive motor assembly removal	4-180
SFP stapler assembly media stack flap and media stack flap actuator removal	4-181
SFP stapler assembly stapler unit assembly removal	4-182
SFP stapler assembly paddle drive motor assembly removal	4-183
SFP stapler assembly sensor (media stack) removal	4-184
SFP stapler assembly sensor (paddle HP) removal	4-185
SFP stapler assembly sensor (stapler access door interlock) removal	4-186
SFP stapler assembly sensor (tamper HP left and right) removal	4-187
SFP stapler assembly sensor (bin full send) removal	4-188
SFP stapler assembly sensor (bin full receive) removal	4-189
SFP stapler assembly sensor (media in stapler) removal	4-189
SFP stapler assembly sensor (deflector HP) removal	4-190
Stapler/stacker controller card assembly removal	4-192
Sensor (HCIT tray raised HP) with cable assembly removal	4-192
Sensor (HCIT pass through) with cable removal	4-195
Sensor (pass through) with cable removal	4-196
Sensor (pass through) with cable removal	4-196
Tray roller catch assembly removal	4-196
Tray roller catch assembly removal	4-197
Upper interface cable assembly removal	4-197
<b>Connector locations and connections</b>	<b>5-1</b>
Connections	5-1
<b>Preventive maintenance</b>	<b>6-1</b>
Safety inspection guide	6-1



Lubrication specifications .....	6-1
Individual maintenance part expected life .....	6-1
Scheduled maintenance .....	6-2
Maintenance kit .....	6-2
<b>Parts catalog .....</b>	<b>7-1</b>
How to use this parts catalog .....	7-1
Assembly 1: Covers .....	7-2
Assembly 2: T650, T652, and T654 Operator panel .....	7-4
Assembly 3: T656dne Operator panel, MPF and smart card .....	7-6
Assembly 4: Drive motor assemblies and duplex .....	7-8
Assembly 5: Media path and ducts .....	7-10
Assembly 6: Printhead, charge, and transfer .....	7-12
Assembly 7: Pick arm assembly, trays, and MPF .....	7-14
Assembly 8: LVPS, fuser and electrical cables 1 .....	7-16
Assembly 9: HVPS, system card, and electrical cables 2 .....	7-18
Assembly 10: 250 Sheet option tray assembly .....	7-20
Assembly 11: 550 Sheet option tray assembly .....	7-22
Assembly 12: HCIT Sheet option tray assembly .....	7-24
Assembly 13: SFP stapler assembly #1 .....	7-26
Assembly 14: SFP stapler assembly #2 .....	7-28
Assembly 15: SFP stapler assembly #3 .....	7-30
Assembly 16: SFP stapler assembly #4 .....	7-32
Assembly 17: 5-bin mailbox #1 .....	7-34
Assembly 18: 5-bin mailbox #2io .....	7-36
Assembly 19: High capacity stacker .....	7-38
Assembly 20: Output expander .....	7-40
Assembly 21: Envelope feeder and external duplex .....	7-42
Assembly 22: RFID UHF Option assembly .....	7-44
Assembly 23: Miscellaneous .....	7-45
Assembly 24: Power cords .....	7-47
Assembly 25: Universal trays and accessories .....	7-48
<b>Index .....</b>	<b>I-1</b>
<b>Part number index .....</b>	<b>I-5</b>



---

## Notices and safety information

The following laser notice labels may be affixed to this printer.

---

### Laser notice

The printer is certified in the U.S. to conform to the requirements of DHHS 21 CFR Subchapter J for Class I (1) laser products, and elsewhere is certified as a Class I laser product conforming to the requirements of IEC 60825-1.

Class I laser products are not considered to be hazardous. The printer contains internally a Class IIIb (3b) laser that is nominally a 5 milliwatt gallium arsenide laser operating in the wavelength region of 770-795 nanometers. The laser system and printer are designed so there is never any human access to laser radiation above a Class I level during normal operation, user maintenance, or prescribed service condition.

---

### Laser

Der Drucker erfüllt gemäß amtlicher Bestätigung der USA die Anforderungen der Bestimmung DHHS (Department of Health and Human Services) 21 CFR Teil J für Laserprodukte der Klasse I (1). In anderen Ländern gilt der Drucker als Laserprodukt der Klasse I, der die Anforderungen der IEC (International Electrotechnical Commission) 60825-1 gemäß amtlicher Bestätigung erfüllt.

Laserprodukte der Klasse I gelten als unschädlich. Im Inneren des Druckers befindet sich ein Laser der Klasse IIIb (3b), bei dem es sich um einen Galliumarsenlaser mit 5 Milliwatt handelt, der Wellen der Länge 770-795 Nanometer ausstrahlt. Das Lasersystem und der Drucker sind so konzipiert, daß im Normalbetrieb, bei der Wartung durch den Benutzer oder bei ordnungsgemäßer Wartung durch den Kundendienst Laserbestrahlung, die Klasse I übersteigen würde, Menschen keinesfalls erreicht.

---

### Avis relatif à l'utilisation de laser

Pour les Etats-Unis : cette imprimante est certifiée conforme aux provisions DHHS 21 CFR alinéa J concernant les produits laser de Classe I (1). Pour les autres pays : cette imprimante répond aux normes IEC 60825-1 relatives aux produits laser de Classe I.

Les produits laser de Classe I sont considérés comme des produits non dangereux. Cette imprimante est équipée d'un laser de Classe IIIb (3b) (arséniure de gallium d'une puissance nominale de 5 milliwatts) émettant sur des longueurs d'onde comprises entre 770 et 795 nanomètres. L'imprimante et son système laser sont conçus pour impossible, dans des conditions normales d'utilisation, d'entretien par l'utilisateur ou de révision, l'exposition à des rayonnements laser supérieurs à des rayonnements de Classe I.

---

### Avvertenze sui prodotti laser

Questa stampante è certificata negli Stati Uniti per essere conforme ai requisiti del DHHS 21 CFR Sottocapitolo J per i prodotti laser di classe 1 ed è certificata negli altri Paesi come prodotto laser di classe 1 conforme ai requisiti della norma CEI 60825-1.

I prodotti laser di classe non sono considerati pericolosi. La stampante contiene al suo interno un laser di classe IIIb (3b) all'arseniuro di gallio della potenza di 5mW che opera sulla lunghezza d'onda compresa tra 770 e 795 nanometri. Il sistema laser e la stampante sono stati progettati in modo tale che le persone a contatto con la stampante, durante il normale funzionamento, le operazioni di servizio o quelle di assistenza tecnica, non ricevano radiazioni laser superiori al livello della classe 1.

---

## Avisos sobre el láser

Se certifica que, en los EE.UU., esta impresora cumple los requisitos para los productos láser de Clase I (1) establecidos en el subcapítulo J de la norma CFR 21 del DHHS (Departamento de Sanidad y Servicios) y, en los demás países, reúne todas las condiciones expuestas en la norma IEC 60825-1 para productos láser de Clase I (1).

Los productos láser de Clase I no se consideran peligrosos. La impresora contiene en su interior un láser de Clase IIIb (3b) de arseniuro de galio de funcionamiento nominal a 5 milivatios en una longitud de onda de 770 a 795 nanómetros. El sistema láser y la impresora están diseñados de forma que ninguna persona pueda verse afectada por ningún tipo de radiación láser superior al nivel de la Clase I durante su uso normal, el mantenimiento realizado por el usuario o cualquier otra situación de servicio técnico.

---

## Declaração sobre Laser

A impressora está certificada nos E.U.A. em conformidade com os requisitos da regulamentação DHHS 21 CFR Subcapítulo J para a Classe I (1) de produtos laser. Em outros locais, está certificada como um produto laser da Classe I, em conformidade com os requisitos da norma IEC 60825-1.

Os produtos laser da Classe I não são considerados perigosos. Internamente, a impressora contém um produto laser da Classe IIIb (3b), designado laser de arseneto de potássio, de 5 milliwatts, operando numa faixa de comprimento de onda entre 770 e 795 nanómetros. O sistema e a impressora laser foram concebidos de forma a nunca existir qualquer possibilidade de acesso humano a radiação laser superior a um nível de Classe I durante a operação normal, a manutenção feita pelo utilizador ou condições de assistência prescritas.

---

## Laserinformatie

De printer voldoet aan de eisen die gesteld worden aan een laserproduct van klasse I. Voor de Verenigde Staten zijn deze eisen vastgelegd in DHHS 21 CFR Subchapter J, voor andere landen in IEC 60825-1.

Laserprodukten van klasse I worden niet als ongevaarlijk aangemerkt. De printer is voorzien van een laser van klasse IIIb (3b), dat wil zeggen een gallium arsenide-laser van 5 milliwatt met een golflengte van 770-795 nanometer. Het lasergedeelte en de printer zijn zo ontworpen dat bij normaal gebruik, bij onderhoud of reparatie conform de voorschriften, nooit blootstelling mogelijk is aan laserstraling boven een niveau zoals voorgeschreven is voor klasse 1.

---

## Lasermeddelelse

Printeren er godkendt som et Klasse I-laserprodukt, i overensstemmelse med kravene i IEC 60825-1.

Klasse I-laserprodukter betragtes ikke som farlige. Printeren indeholder internt en Klasse IIIB (3b)-laser, der nominelt er en 5 milliwatt galliumarsenid laser, som arbejder på bølgelængdeområdet 770-795 nanometer. Lasersystemet og printeren er udformet således, at mennesker aldrig udsættes for en laserstråling over Klasse I-niveau ved normal drift, brugervedligeholdelse eller obligatoriske servicebetingelser.

---

## Laserilmoitus

Tämä tulostin on sertifioitu Yhdysvalloissa DHHS 21 CFR Subchapter J -standardin mukaiseksi luokan I (1) -lasertuotteeksi ja muualla IEC 60825-1 -standardin mukaiseksi luokan I lasertuotteeksi.

Luokan I lasertuotteita ei pidetä haitallisina. Tulostimen sisällä on luokan IIIb (3b) laser, joka on nimellisteholtaan 5 mW:n galliumarsenidilaser ja toimii 770 - 795 nanometrin aallonpituuksilla. Laserjärjestelmä ja tulostin ovat rakenteeltaan sellaisia, että käyttäjä ei joudu alttiiksi luokkaa 1 suuremmalle säteilylle normaalin käytön, ylläpidon tai huollon aikana.

---

## Huomautus laserlaitteesta

Tämä kirjoitin on Yhdysvalloissa luokan I (1) laserlaitteiden DHHS 21 CFR Subchapter J -määrityksen mukainen ja muualla luokan I laserlaitteiden IEC 60825-1 -määrityksen mukainen.

Luokan I laserlaitteiden ei katsota olevan vaarallisia käyttäjälle. Kirjoittimessa on sisäinen luokan IIIb (3b) 5 milliwatin galliumarsenidilaser, joka toimii aaltoalueella 770 - 795 nanometriä. Laserjärjestelmä ja kirjoitin on suunniteltu siten, että käyttäjä ei altistu luokan I määräytyksiä voimakkaammalle säteilylle kirjoittimen normaalin toiminnan, käyttäjän tekemien huoltotoimien tai muiden huoltotoimien yhteydessä.

**VARO!** Avattaessa ja suojalukitus ohitettaessa olet alttiina näkymättömälle lasersäteilylle. Älä katso säteeseen.

**WARNING!** Osynlig laserstrålning när denna del är öppnad och spärren är urkopplad. Betrakta ej strålen.

---

## Laser-notis

Denna skrivare är i USA certifierad att motsvara kraven i DHHS 21 CFR, underparagraf J för laserprodukter av Klass I (1). I andra länder uppfyller skrivaren kraven för laserprodukter av Klass I enligt kraven i IEC 60825-1.

Laserprodukter i Klass I anses ej hälsovådliga. Skrivaren har en inbyggd laser av Klass IIIb (3b) som består av en laserenhet av gallium-arsenid på 5 milliwatt som arbetar i våglängdsområdet 770-795 nanometer. Lasersystemet och skrivaren är utformade så att det aldrig finns risk för att någon person utsätts för laserstrålning över Klass I-nivå vid normal användning, underhåll som utförs av användaren eller annan föreskriven serviceåtgärd.

---

## Laser-melding

Skriveren er godkjent i USA etter kravene i DHHS 21 CFR, underkapittel J, for klasse I (1) laserprodukter, og er i andre land godkjent som et Klasse I-laserprodukt i samsvar med kravene i IEC 60825-1.

Klasse I-laserprodukter er ikke å betrakte som farlige. Skriveren inneholder internt en klasse IIIb (3b)-laser, som består av en gallium-arsenlaserenhet som avgir stråling i bølgelengdeområdet 770-795 nanometer. Lasersystemet og skriveren er utformet slik at personer aldri utsettes for laserstråling ut over klasse I-nivå under vanlig bruk, vedlikehold som utføres av brukeren, eller foreskrevne serviceoperasjoner.

---

## Avís sobre el Làser

Segons ha estat certificat als Estats Units, aquesta impressora compleix els requisits de DHHS 21 CFR, apartat J, pels productes làser de classe I (1), i segons ha estat certificat en altres llocs, és un producte làser de classe I que compleix els requisits d'IEC 60825-1.

Els productes làser de classe I no es consideren perillosos. Aquesta impressora conté un làser de classe IIIb (3b) d'arseniür de gal.li, nominalment de 5 mil.liwats, i funciona a la regió de longitud d'ona de 770-795 nanòmetres. El sistema làser i la impressora han sigut concebuts de manera que mai hi hagi exposició a la radiació làser per sobre d'un nivell de classe I durant una operació normal, durant les tasques de manteniment d'usuari ni durant els serveis que satisfacin les condicions prescrites.

---

### レーザーに関するお知らせ

このプリンターは、米国ではDHHS 21 CFRサブチャプターJのクラスI(1)の基準を満たしたレーザー製品であることが証明されています。また米国以外ではIEC 825の基準を満たしたクラスIのレーザー製品であることが証明されています。

クラスIのレーザー製品には危険性はないと考えられています。このプリンターはクラスIIIb(3b)のレーザーを内蔵しています。このレーザーは、波長が770～795ナノメートルの範囲で、通常5ミリワットのガリウム砒化物を放射するレーザーです。このレーザーシステムとプリンターは、通常の操作、ユーザのメンテナンス、規定された修理においては、人体がクラスIのレベル以上のレーザー放射に晒されることのないよう設計されています。

---

### 注意：

本打印机被美国认证合乎 DHHS 21 CFR Subchapter J 对分类 I (1) 激光产品的标准，而在其他地区则被认证合乎 IEC 825 的标准。

分类 I 激光产品一般认为不具危险性，本打印机内部含有分类 IIIb (3b) 的激光，在操作过程中会产生 5 毫瓦含镓及砷的微量激光，其波长范围在 770-795 nm 之间。本激光系统及打印机的设计，在一般操作、使用者维护或规定内的维修情况下，不会使人体接触分类 I 以上等级的辐射。

---

본프린터는 1등급 레이저 제품들에 대한 DHHS 21 CFR Subchapter 3의 규정을 준수하고 있음을 미국에서 인증받았으며, 그외의 나라에서도 IEC 825 규정을 준수하는 1등급 레이저 제품으로서 인증을 받았습니다.

1등급 레이저 제품들은 안전한 것으로 간주됩니다. 본 프린터는 5 밀리와트 갈륨 아르세나이드 레이저로서 770-795 나노미터의 파장대에서 활동하는 Class III (3b) 레이저를 내부에 갖고 있습니다. 본 레이저 시스템과 프린터는 정상 작동 중이나 유지 보수 중 또는 규정된 서비스 상태에서 상기의 Class I 수준의 레이저 방출에 사람이 절대 접근할 수 없도록 설계되어 있습니다.

4062-XXX



## Lithium warning



### CAUTION

This product contains a lithium battery. THERE IS A RISK OF EXPLOSION IF THE BATTERY IS REPLACED BY AN INCORRECT TYPE. Discard used batteries according to the battery manufacturer's instructions and local regulations.

## Safety information

- The safety of this product is based on testing and approvals of the original design and specific components. The manufacturer is not responsible for safety in the event of use of unauthorized replacement parts.
- The maintenance information for this product has been prepared for use by a professional service person and is not intended to be used by others.
- There may be an increased risk of electric shock and personal injury during disassembly and servicing of this product. Professional service personnel should understand this and take necessary precautions.
-  **CAUTION:** When you see this symbol, there is a danger from hazardous voltage in the area of the product where you are working. Unplug the product before you begin, or use caution if the product must receive power in order to perform the task.

## Consignes de sécurité

- La sécurité de ce produit repose sur des tests et des agrégations portant sur sa conception d'origine et sur des composants particuliers. Le fabricant n'assume aucune responsabilité concernant la sécurité en cas d'utilisation de pièces de rechange non agréées.
- Les consignes d'entretien et de réparation de ce produit s'adressent uniquement à un personnel de maintenance qualifié.
- Le démontage et l'entretien de ce produit pouvant présenter certains risques électriques, le personnel d'entretien qualifié devra prendre toutes les précautions nécessaires.
-  **ATTENTION :** Ce symbole indique la présence d'une tension dangereuse dans la partie du produit sur laquelle vous travaillez. Débranchez le produit avant de commencer ou faites preuve de vigilance si l'exécution de la tâche exige que le produit reste sous tension.

## Norme di sicurezza

- La sicurezza del prodotto si basa sui test e sull'approvazione del progetto originale e dei componenti specifici. Il produttore non è responsabile per la sicurezza in caso di sostituzione non autorizzata delle parti.
- Le informazioni riguardanti la manutenzione di questo prodotto sono indirizzate soltanto al personale di assistenza autorizzato.
- Durante lo smontaggio e la manutenzione di questo prodotto, il rischio di subire scosse elettriche e danni alla persona è più elevato. Il personale di assistenza autorizzato deve, quindi, adottare le precauzioni necessarie.
-  **ATTENZIONE:** Questo simbolo indica la presenza di tensione pericolosa nell'area del prodotto. Scollegare il prodotto prima di iniziare o usare cautela se il prodotto deve essere alimentato per eseguire l'intervento.

---

## Sicherheitshinweise

- Die Sicherheit dieses Produkts basiert auf Tests und Zulassungen des ursprünglichen Modells und bestimmter Bauteile. Bei Verwendung nicht genehmigter Ersatzteile wird vom Hersteller keine Verantwortung oder Haftung für die Sicherheit übernommen.
- Die Wartungsinformationen für dieses Produkt sind ausschließlich für die Verwendung durch einen Wartungsfachmann bestimmt.
- Während des Auseinandernehmens und der Wartung des Geräts besteht ein zusätzliches Risiko eines elektrischen Schlags und körperlicher Verletzung. Das zuständige Fachpersonal sollte entsprechende Vorsichtsmaßnahmen treffen.
-  **ACHTUNG:** Dieses Symbol weist auf eine gefährliche elektrische Spannung hin, die in diesem Bereich des Produkts auftreten kann. Ziehen Sie vor den Arbeiten am Gerät den Netzstecker des Geräts, bzw. arbeiten Sie mit großer Vorsicht, wenn das Produkt für die Ausführung der Arbeiten an den Strom angeschlossen sein muß.

---

## Pautas de Seguridad

- La seguridad de este producto se basa en pruebas y aprobaciones del diseño original y componentes específicos. El fabricante no es responsable de la seguridad en caso de uso de piezas de repuesto no autorizadas.
- La información sobre el mantenimiento de este producto está dirigida exclusivamente al personal cualificado de mantenimiento.
- Existe mayor riesgo de descarga eléctrica y de daños personales durante el desmontaje y la reparación de la máquina. El personal cualificado debe ser consciente de este peligro y tomar las precauciones necesarias.
-  **PRECAUCIÓN:** este símbolo indica que el voltaje de la parte del equipo con la que está trabajando es peligroso. Antes de empezar, desenchufe el equipo o tenga cuidado si, para trabajar con él, debe conectarlo.

---

## Informações de Segurança

- A segurança deste produto baseia-se em testes e aprovações do modelo original e de componentes específicos. O fabricante não é responsável pela segurança, no caso de uso de peças de substituição não autorizadas.
- As informações de segurança relativas a este produto destinam-se a profissionais destes serviços e não devem ser utilizadas por outras pessoas.
- Risco de choques eléctricos e ferimentos graves durante a desmontagem e manutenção deste produto. Os profissionais destes serviços devem estar avisados deste facto e tomar os cuidados necessários.
-  **CUIDADO:** Quando vir este símbolo, existe a possível presença de uma potencial tensão perigosa na zona do produto em que está a trabalhar. Antes de começar, desligue o produto da tomada eléctrica ou seja cuidadoso caso o produto tenha de estar ligado à corrente eléctrica para realizar a tarefa necessária.

## Informació de Seguretat

- La seguretat d'aquest producte es basa en l'avaluació i aprovació del disseny original i els components específics.  
El fabricant no es fa responsable de les qüestions de seguretat si s'utilitzen peces de recanvi no autoritzades.
- La informació pel manteniment d'aquest producte està orientada exclusivament a professionals i no està destinada a ningú que no ho sigui.
- El risc de xoc elèctric i de danys personals pot augmentar durant el procés de desmuntatge i de servei d'aquest producte. El personal professional ha d'estar-ne assabentat i prendre les mesures convenients.
-  **PRECAUCIÓ:** aquest símbol indica que el voltatge de la part de l'equip amb la qual esteu treballant és perillós. Abans de començar, desendolieu l'equip o extremeu les precaucions si, per treballar amb l'equip, l'heu de connectar.

## 안전 사항

- 본 제품은 원래 설계 및 특정 구성품에 대한 테스트 결과로 안정성이 입증된 것입니다. 따라서 무허가 교체부품을 사용하는 경우에는 제조업체에서 안전에 대한 책임을 지지 않습니다.
- 본 제품에 관한 유지 보수 설명서는 전문 서비스 기술자용으로 작성된 것이므로, 비전문가는 사용할 수 없습니다.
- 본 제품을 해체하거나 정비할 경우, 전기적인 충격을 받거나 상처를 입을 위험이 커집니다. 전문 서비스 기술자는 이 사실을 숙지하고, 필요한 예방 조치를 취하도록 하십시오.
-  **주의:** 이 표시는 해당영역에서 고압전류가 흐른다는 위험 표시입니다. 시작전에 플러그를 뽑으시거나, 주의를 기울여 주시기 바랍니다.

## 安全信息

- 本产品的安全性以原来设计和特定产品的测试结果和认证为基础。万一使用未经许可的替换部件，制造商不对安全性负责。
- 本产品的维护信息仅供专业服务人员使用，并不打算让其他人使用。
- 本产品在拆卸、维修时，遭受电击或人员受伤的危险性会增高，专业服务人员对这点必须有所了解，并采取必要的预防措施。
-  **切记:** 当您看到此符号时，说明在您工作的产品区域有危险电压的存在。请在开始操作前拔掉产品的电源线，或者在产品必须使用电源来执行任务时，小心从事。

## Preface

This manual contains maintenance procedures for service personnel. It is divided into the following chapters:

1. **General information** contains a general description of the printer and the maintenance approach used to repair it. Special tools and test equipment, as well as general environmental and safety instructions, are discussed.
  2. **Diagnostic information** contains an error indicator table, symptom tables, and service checks used to isolate failing field replaceable units (FRUs).
  3. **Diagnostic aids** contains tests and checks used to locate or repeat symptoms of printer problems.
  4. **Repair information** provides instructions for making printer adjustments and removing and installing FRUs.
  5. **Connector locations** uses illustrations to identify the connector locations and test points on the printer.
  6. **Preventive maintenance** contains the lubrication specifications and recommendations to prevent problems.
  7. **Parts catalog** contains illustrations and part numbers for individual FRUs.
- Appendix A** contains service tips and information.  
**Appendix B** contains representative print samples.

---

## Conventions

**Note:** A note provides additional information.

**Warning:** A warning identifies something that might damage the product hardware or software.

There are several types of caution statements:

	<p><b>CAUTION</b></p> <p>A caution identifies something that might cause a servicer harm.</p>
---	---

	<p><b>CAUTION</b></p> <p>This type of caution indicates there is a danger from hazardous voltage in the area of the product where you are working. Unplug the product before you begin, or use caution if the product must receive power in order to perform the task.</p>
---	--

	<p><b>CAUTION</b></p> <p>This type of caution indicates a hot surface.</p>
---	--

	<p><b>CAUTION</b></p> <p>This type of caution indicates a tipping hazard.</p>
---	---

## 1. General information

The Lexmark™ laser printers are letter-quality page printers designed to attach to personal computers and to most computer networks.

The Lexmark laser printers are available in the following models:

Machine type	Model	Configuration
4062-01A	T650n	Network
4062-21A	T652n	Network
4062-23A	T652dn	Network
4062-41A	T654n	Network
4062-43A	T654dn	Network
4062-630	T656dne	Network

---

## Maintenance approach

The diagnostic information in this manual leads you to the correct field replaceable unit (FRU) or part. Use the service error codes, user status messages, user error messages, service checks, and diagnostic aids to determine the printer problem and repair the failure. After you complete the repair, perform tests as needed to verify the repair. See **“Start” on page 2-1**.

---

## Options

### Available internal options

- Memory cards
  - Printer memory
  - Flash memory
  - Fonts
- Firmware cards
  - Bar Code and Forms
  - IPDS and SCS/TNe
  - PrintCryption™
  - PRESCRIBE
- Printer hard disk
- Lexmark™ Internal Solutions Ports (ISP)
  - RS-232-C serial interface ISP
  - Parallel 1284-B interface ISP
  - MarkNet™ N8150 802.11 b/g/n Wireless ISP
  - MarkNet N8130 10/100 Thick Fiber ISP
  - MarkNet N8120 10/100/1000 Thick Ethernet ISP
- MarkNet N8110 v.34 Fax Card

The following options are available. Some options are not available in every country. Contact your point of purchase for options available in your country.

### Media handling options

- 250- and 550-sheet paper trays of A4, letter, A5, B5, Executive, folio, statement, and legal size
- 250-sheet universally adjustable tray
- 250- and 550-sheet paper drawers
- 2000-sheet high-capacity feeder
- Envelope feeder (Not for use with the T656dne)
- Duplex option—250-sheet (external)
- Duplex option—550-sheet (internal on duplex versions of T652 and T654)
- Output expander
- High-capacity output stacker
- StapleSmart™ Finisher
- 5-bin Mailbox
- Vertical Kiosk Presenter
- Horizontal Kiosk Presenter
- RFID UHF (only for T654)

# Printer configurations

## Basic model

The following illustration shows the basic printer model.

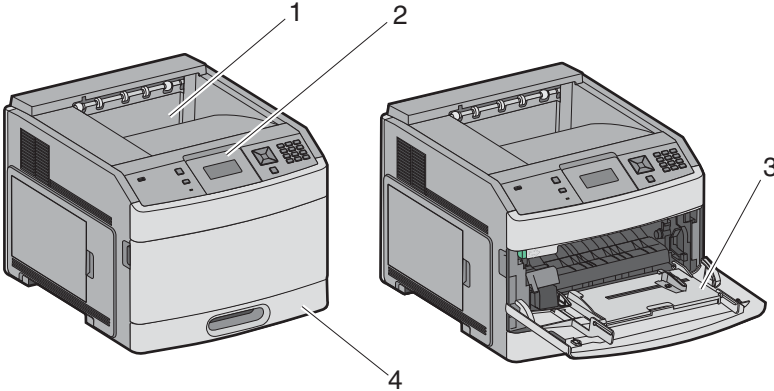

	<b>Feature</b>	<b>Paper Capacity<sup>1</sup></b>
<b>1</b>	Standard exit bin	250- or 550-sheet
<b>2</b>	Printer control panel	NA
<b>3</b>	Multipurpose feeder	100 sheets
<b>4</b>	Standard tray (Tray 1)	250- or 550-sheets

<sup>1</sup>Based on 75 g/m<sup>2</sup> (20 lb.) paper.

### Fully configured model

The following illustration shows the fully configured printer model.



**CAUTION:** —TIPPING HAZARD: Floor-mounted configurations require additional furniture for stability. You must use either a printer stand or printer base if you are using a 2000-sheet tray, a duplex unit, and an input option, or more than one input option.

For more information, see [www.lexmark.com/publications/furniture\\_safety](http://www.lexmark.com/publications/furniture_safety).

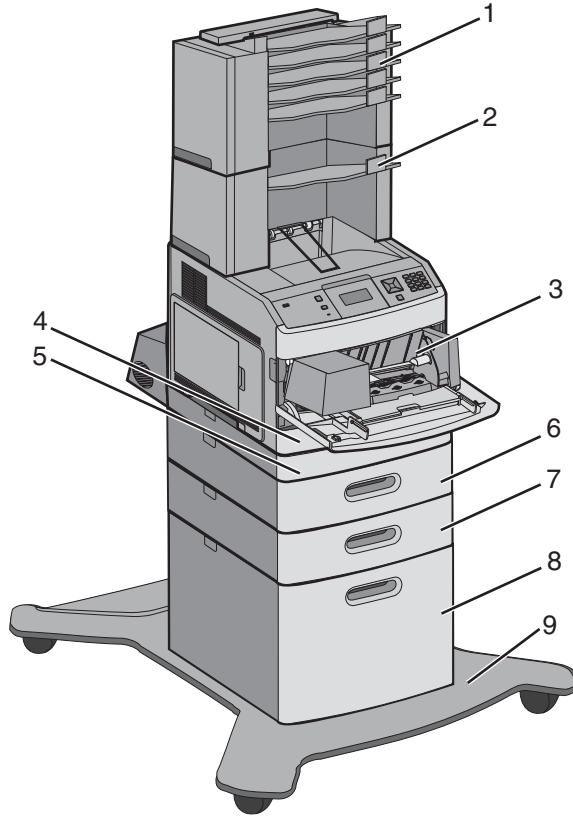



	Feature/Option	Paper Capacity <sup>1</sup>
1	5-bin mailbox <sup>2</sup>	500 sheets
2	Output expander <sup>3</sup>	550 sheets
3	Envelope feeder (Not for use with the T656dne)	85 envelopes
4	Standard tray (Tray 1)	250 or 550-sheets
5	Duplex unit <sup>4</sup>	Not applicable
6	Optional tray (Tray 2)	250- or 550-sheets
7	Optional tray (Tray 3)	250- or 550-sheets
8	Optional 2000-sheet tray (Tray 4)	2000 sheets
9	Caster base	Not applicable

<sup>1</sup> Based on 75 g/m<sup>2</sup> (20 lb.) paper.

<sup>2</sup> Up to two 5-bin mailbox units are supported.

<sup>3</sup> The printer supports up to three output expander units, or one output expander combined with one 5-bin mailbox, one high capacity output expander (not depicted), or one stapler unit (not depicted).

<sup>4</sup> Optional external duplex unit for the T650 model. All other models are available with or without internal duplex unit.



**CAUTION:** Floor-mounted configurations require furniture for stability. You must use either a printer stand or printer base if you are using a 2000-sheet drawer. Certain other configurations also must have a printer stand or printer base. More information is available at our Lexmark Web site at [www.lexmark.com/multifunction printers](http://www.lexmark.com/multifunctionprinters).

## Supported paper sizes, types, and weights

The following tables provide information on standard and optional paper sources and the types of paper they support.

**Note:** For an unlisted paper size, select the closest larger listed size.

### Paper sizes supported by the printer

Paper size	Dimensions	250-or 550-sheet trays (standard or optional)	Optional 2000-sheet tray	Multipurpose feeder	Duplex unit
A4	210 x 297 mm (8.3 x 11.7 in.)	<b>x</b>	<b>x</b>	<b>x</b>	<b>x</b>
A5	148 x 210 mm (5.8 x 8.3 in.)	<b>x</b>		<b>x</b>	<b>x</b>
A6 <sup>1,2</sup>	105 x 148 mm (4.1 x 5.8 in.)			<b>x</b>	
J15 B5	182 x 257 mm (7.2 x 10.1 in.)	<b>x</b>		<b>x</b>	<b>x</b>
Letter	216 x 279 mm (8.5 x 11 in.)	<b>x</b>	<b>x</b>	<b>x</b>	<b>x</b>
Legal	216 x 356 mm (8.5 x 14 in.)	<b>x</b>	<b>x</b>	<b>x</b>	<b>x</b>
Executive	184 x 267 mm (7.3 x 10.5 in.)	<b>x</b>		<b>x</b>	<b>x</b>
Oficio <sup>1</sup>	216 x 340 mm (8.5 x 13.4 in.)	<b>x</b>		<b>x</b>	<b>x</b>
Folio <sup>1</sup>	216 x 330 mm (8.5 x 13 in.)	<b>x</b>		<b>x</b>	<b>x</b>
Statement <sup>1</sup>	140 x 216 mm (5.5 x 8.5 in.)	<b>x</b>		<b>x</b>	
Universal <sup>3,4</sup>	138 x 210 mm (5.5 x 8.3 in.) up to 216 x 356 mm (8.5 x 14 in.)	<b>x</b>		<b>x</b>	
	70 x 127 mm (2.8 x 5 in.) up to 216 x 356 mm (8.5 x 14 in.)			<b>x</b>	
	148 x 182 mm (5.8 x 7.7 in.) up to 216 x 356 mm (8.5 x 14 in.)	<b>x</b>		<b>x</b>	<b>x</b>
7 3/4 Envelopes (Monarch)	98 x 191 mm (3.9 x 7.5 in.)			<b>x</b>	
9 Envelope	98 x 225 mm (3.9 x 8.9 in.)			<b>x</b>	
10 Envelope	105 x 241 mm (4.1 x 9.5 in.)			<b>x</b>	
DL Envelope	110 x 220 mm (4.3 x 8.7 in.)			<b>x</b>	

Paper size	Dimensions	250-or 550-sheet trays (standard or optional)	Optional 2000-sheet tray	Multipurpose feeder	Duplex unit
Other Envelope	98 x 162 mm (3.9 x 6.4 in.) to 176 x 250 mm (6.9 x 9.8 in.)			x	
<p><sup>1</sup>This size appears in the Paper Size menu only when the paper source does not support size sensing or when size sensing is turned off.</p> <p><sup>2</sup>Only the standard exit bin supports this size.</p> <p><sup>3</sup>This size setting formats the page for 216 x 356 mm (8.5 x 14 in.) unless the size is specified by the software application.</p> <p><sup>4</sup>To support duplexing, the Universal width must be between 148 mm (5.8 in) and 216 mm (8.5 in); Universal length must be between 182 mm (7.2 in) and 356 mm (14 in).</p>					

### Paper types and weights supported by the printer

Paper type	250-or 550-sheet trays (standard or optional)	Optional 2000-sheet tray	Multipurpose feeder	Duplex unit
Paper <ul style="list-style-type: none"> <li>• Plain</li> <li>• Bond</li> <li>• Colored</li> <li>• Custom</li> <li>• Letterhead</li> <li>• Light</li> <li>• Heavy</li> <li>• Preprinted</li> <li>• Rough/Cotton</li> <li>• Recycled</li> </ul>	x	x	x	x
Card stock	x	x	x	x
Envelopes			x	
Labels <sup>1</sup>	x	x	x	x
Transparencies	x	x	x	x
<p><sup>1</sup>Printing labels requires a special label fuser cleaner which prevents duplexing. The label fuser cleaner is included with the special cartridge required for label applications.</p>				

### Paper types and weights supported by the output bins

Use this table to determine the possible output destinations of print jobs which use supported paper types and weights. The paper capacity of each output bin is listed in parentheses. Paper capacity estimations are calculated based on 75 g/m<sup>2</sup> (20 lb) paper.

The finisher supports 60-176 g/m<sup>2</sup> (16-47 lb) paper weights.

Paper type	Standard exit bin (350 or 550 sheets)	Optional hardware		
		Output Expander (550 sheets) or High Capacity Output stacker (1850 sheets)	5-Bin Mailbox (500 sheets) <sup>1</sup>	StapleSmart II Finisher (500 sheets) <sup>2</sup>
Paper <ul style="list-style-type: none"> <li>• Plain</li> <li>• Bond</li> <li>• Colored</li> <li>• Custom</li> <li>• Letterhead</li> <li>• Light</li> <li>• Heavy</li> <li>• Preprinted</li> <li>• Rough/Cotton</li> <li>• Recycled</li> </ul>	<b>x</b>	<b>x</b>	<b>x</b>	<b>x</b>
Card stock	<b>x</b>	<b>x</b>		
Envelopes				
Labels <sup>1</sup>	<b>x</b>	<b>x</b>		
Transparencies	<b>x</b>	<b>x</b>		
<sup>1</sup> Supports 60-90 g/m <sup>2</sup> (16-24 lb) paper weights. <sup>2</sup> Maximum of 50 sheets of 75 g/m <sup>2</sup> (20 lb) paper per stapled packet. Results may vary with heavier paper.				

## Tools required

Flat-blade screwdrivers, various sizes  
 #1 Phillips screwdriver, magnetic  
 #2 Phillips screwdriver, magnetic  
 #2 Phillips screwdriver, magnetic short-blade  
 7/32 inch (5.5 mm) open-end wrench  
 7.0 mm nut driver  
 Needle nose pliers  
 Diagonal side cutters  
 Spring hook  
 Analog or digital multimeter  
 Flash light (optional)

---

## Acronyms

BLDC	Brushless DC motor
CRU	Customer Replaceable Unit
CSU	Customer setup
DIMM	Dual Inline Memory Module
DRAM	Dynamic Random Access Memory
DVM	Digital multimeter
EDO	Enhanced Data Out
EEPROM	Electrically Erasable Programmable Read-Only Memory
EP	Electrophotographic process
EPROM	Erasable Programmable Read-Only Memory
ESD	Electrostatic Discharge
FRU	Field Replaceable Unit
GB	Gigabyte
HCIT	High-capacity Input Tray
HVPS	High Voltage Power Supply
ITC	Internal Tray Card
LASER	Light Amplification by Stimulated Emission of Radiation
LCD	Liquid Crystal Display
LED	Light-Emitting Diode
LVPS	Low Voltage Power Supply
MPF	Multipurpose feeder
MROM	Masked Read Only Memory
MS	Microswitch
NVRAM	Nonvolatile Random Access Memory
OEM	Original Equipment Manufacturer
OPT	Optical Sensor
PC	Photoconductor
pel	Picture element
POR	Power-On Reset
POST	Power-On Self Test
PP	Parts Packet
PWM	Pulse Width Modulation
RFID	Radio Frequency Identification
RIP	Raster Imaging Processor
ROM	Read Only Memory
SDRAM	Synchronous Dynamic Random Access Memory
SIMM	Single Inline Memory Module
SRAM	Static Random Access Memory
UAT	Universally Adjustable Tray)
UPR	Used Parts Return
V ac	Volts alternating current
V dc	Volts direct current
VOM	Volt Ohmmeter



## 2. Diagnostic information

### Start



**CAUTION:**

Unplug the power cord from the electrical outlet before you connect or disconnect any cable electronic board or assembly.



**CAUTION:**

If the printer is kept on, never touch the conductive parts if not specifically required. The power switch and inlet of the low voltage power supply card (LVPS card) assembly is live even while the power supply is cut off. Never touch the live parts.



**CAUTION:**

Be careful to avoid burns by safely handling hot parts.



**CAUTION**

The printer weight is greater than 18kg (40 lbs) and requires two or more trained personnel to lift it safely. Use the hand holds on the side of the printer. Make sure your fingers are not under the printer when you lift or set the printer down.

**WARNING:** When operating the driving units using the diagnostics or other tools, be sure to keep them covered unless otherwise specified.

**WARNING:** When operating the driving units using the diagnostics or other tools, never touch the driving units. When operating the driving units using diagnostics or other tools, be sure to follow the procedures in this manual.

**WARNING:** Servicicers should wear a wrist band or the like to remove static electricity from their body, grounding their body while working. Go to **“Handling ESD-sensitive parts” on page 4-1**.

**Note:** There may be printer error messages that are not contained in this service manual. Call your next level support for assistance.

---

## Confirm the installation status

Be sure to check the following items before starting the troubleshooting procedures.

- With the power cord unplugged from the wall outlet, check that the cord is free from breakage, short-circuit, disconnected wire, or incorrect connection in the power cord.
- The printer is properly grounded. Check the power cord ground terminal.
- The printer is not installed at a place subjected to extreme temperature, extreme humidity or rapid changes in temperature.
- The printer is not installed close to water service, humidifier, heat generating unit, fire, in a very dusty place, or a place exposed to air flow from the air conditioning system.
- The printer is not installed in a place where volatile gas or inflammable gas is generated.
- The printer is not installed in direct sun.
- The printer is installed on a level and stable surface.
- Media meets specifications and is installed properly.
- Customer maintenance parts have been replaced at the specified intervals.
- Check all attached options for proper attachment and electrical connection.
- Refer to the *User's Guide* for proper installation.



---

## Power-on Reset sequence

The following is an example of the events that occur during the POR sequence:

1. Turn the machine on.
2. The Lexmark splash screen appears with a progress bar in the center until the code is loaded.
3. The fuser cooling fan turns on.
4. The fuser unit assembly lamps turn on.
5. The system card assembly cooling fan turns on.
6. Operator panel LED becomes solid.
7. The transport motor turns on.



### ***Entering Diagnostics mode***







1. Turn the printer off.
2. Press and hold  and .
3. Turn the printer on.
4. Release the buttons after 10 seconds.



## User attendance messages



Error code or message	Error contents	Description/Action	Possible repair actions
System Timeout	System Timeout	The system detects a firmware component that is no longer responding.	Turn the power off; wait a few seconds, and then turn the power back on.
30.XX	Invalid Refill Change Cartridge	Message is cleared when a new print cartridge is installed.	Install the proper print cartridge.
31.XX	Defective Cartridge	Error code 31 displays when the top front cover is closed and a defective print cartridge is detected. It may take the printer 10-20 seconds to determine if the print cartridge is defective.	<ol style="list-style-type: none"> <li>1. Install the proper print cartridge.</li> <li>2. Ensure the print cartridge ID connector assembly is properly connected.</li> <li>3. Replace the print cartridge ID connector assembly if problem remains. Go to <b>“Print cartridge ID connector assembly removal (T650, T652, T654)” on page 4-59.</b></li> </ol>
32.XX	Cartridge part number X unsupported by device	Error 32 displays when the top cover is closed and an unsupported print cartridge is detected. It may take the printer 10-20 seconds to determine if the print cartridge is supported.	Install the proper print cartridge.
34	Short Paper	The printer determines the paper length is too short to print the formatted data. This occurs when the printer does not know the actual paper size loaded in the tray. For auto-size sensing trays, this error occurs if the paper stop is in the incorrect position. Make sure the Paper Size setting is correct for the size paper that is being used.	<ol style="list-style-type: none"> <li>1. Ensure the media tray guides are properly set for the media being used.</li> <li>2. Ensure the Switch media size is properly connected.</li> <li>3. Replace the switch media size if problem remains. Go to <b>“Switch (media size) assembly removal (T650, T652, T654)” on page 4-74.</b></li> <li>4. Replace the media tray assembly if problem remains.</li> </ol>

Error code or message	Error contents	Description/Action	Possible repair actions
35	Res Save Off Deficient Memory	<p>This IR is displayed when the printer lacks sufficient memory to enable Resource Save. This message usually indicates the user has allocated too much memory for one or more of the printer's link buffers; however, modification of other printer settings which affect the amount of available memory may also create this condition. If the user desires to enable Resource Save after this message has been posted, it is recommended the user either install additional memory or set each link buffer back to the Auto value.</p> <p>Once all link buffers are returned to Auto, the user should exit the menus to activate the link buffer changes. Once the printer returns to the Ready state, the user may then enable Resource Save and then finally go back and modify the link buffers again. The user should note the reduction of available memory to the link buffers when Resource Save has been enabled as opposed to the memory available when Resource Save is disabled.</p>	<p>This message displays when the printer lacks sufficient memory to enable Resource Save. This message usually indicates the user has allocated too much memory for one or more of the printer link buffers; however, modification of other printer settings which affect the amount of available memory may also create this condition. If restoration of Resource Save is required after this message is received, the customer should install additional memory or set each link buffer to Auto. Once all link buffers are returned to Auto, you should exit the menu to activate the link buffer changes. Once the printer returns to the Ready state, you can enable Resource Save and go back and modify the link buffers again. Note the reduction of available memory to the link buffers when Resource Save has been enabled, and compare it to the memory available when Resource Save is disabled.</p> <ul style="list-style-type: none"> <li>• Press  to disable Resource Save and continue printing.</li> </ul> <p>To enable Resource Save after you get this message:</p> <ul style="list-style-type: none"> <li>- Make sure the link buffers are set to Auto, then exit the menus to activate the link buffer changes.</li> <li>- When Ready is displayed, enable Resource Save.</li> </ul> <ul style="list-style-type: none"> <li>• Install additional memory.</li> </ul>
37	Insufficient Collation Area	<p>This message displays when the printer memory is insufficient to perform the Flash Memory Defragment operation.</p> <p><b>Note:</b> This message is posted prior to the actual start of the defragment operation. The printer code determines if enough printer memory is available to complete the defragment operation. The user should not be concerned with losing resources stored in the flash option.</p>	<p>The following actions may be taken:</p> <ul style="list-style-type: none"> <li>• Press  to clear the message. To perform the defragment operation: <ul style="list-style-type: none"> <li>- Delete fonts, macros, and other data in RAM.</li> <li>- Install additional printer memory.</li> </ul> </li> <li>• Press  until Busy/Waiting appears. The following actions are available: <ul style="list-style-type: none"> <li>- Cancel Job</li> <li>- Reset Printer</li> <li>- Reset Active Bin</li> </ul> </li> </ul>





Error code or message	Error contents	Description/Action	Possible repair actions
37	Insufficient Memory	This message displays when the printer memory used to restore the Print and Hold jobs from the disk and found that some or all of the jobs could not be restored. The printer ran out of memory while attempting to restore the jobs.	<p>The following actions may be taken:</p> <ul style="list-style-type: none"> <li>• Press  to clear the message. Some of the Print and Hold jobs on the disk will not be restored. They remain on the disk, but cannot be accessed.</li> <li>• Press  until Busy/Waiting appears. The following functions may be available: <ul style="list-style-type: none"> <li>- Cancel Job</li> <li>- Reset Printer</li> </ul> </li> </ul> <p>Reset Active Bin</p>
38	Memory Full	This message displays when the printer is processing an incoming job and there is insufficient memory available to continue processing the job.	<p>The following actions may be taken:</p> <ul style="list-style-type: none"> <li>• Press  to clear the message. Perform the defragment operation: <ul style="list-style-type: none"> <li>- Perform the defragment operation</li> <li>- Delete fonts, macros, and other data in RAM</li> <li>- Install additional memory</li> </ul> </li> <li>• Press  to display Busy/Waiting. The following functions may be available: <ul style="list-style-type: none"> <li>- Cancel Job</li> <li>- Reset Printer</li> </ul> </li> </ul> <p>Reset Active Bin</p>
39	Complex Page	This message displays when the page is too complex to print. The following actions may be taken:	<p>The following actions may be taken:</p> <ul style="list-style-type: none"> <li>• Press  to clear the message and continue the job. Some data loss may occur. Simplify the print job and reprint, if necessary.</li> <li>• Press  until Busy/Waiting appears. The following selections are possible: <ul style="list-style-type: none"> <li>- Cancel Job</li> <li>- Reset Printer</li> </ul> </li> </ul> <p>Reset Active Bin</p>

Error code or message	Error contents	Description/Action	Possible repair actions
44.01	RFID Error	Bad tag error: a tag has failed to program, or the "Retry Count" has been exceeded. <b>Note:</b> This error is not a data parsing error, but indicates bad RFID media. It is posted only if the "Stop on Error" menu setting is set to "ON".	<ol style="list-style-type: none"> <li>1. Retest using new RFID media.</li> <li>2. Check the RFID firmware card, RFID interface card, RFID cable, and RFID option for correct installation. Go to "<b>High capacity input tray (HCIT) pick arm bracket assembly removal</b>" on page 4-130.</li> <li>3. Replace the RFID UHF option.</li> </ol>
44.11	RFID Error	Generic parse error	<ol style="list-style-type: none"> <li>1. These error codes most likely indicate a problem with the customer's datastream, and not the RFID Option itself. Ensure there is nothing wrong with the customer's datastream.</li> <li>2. Check the RFID firmware card, RFID interface card, RFID cable, and RFID option for correct installation. Go to "<b>High capacity input tray (HCIT) pick arm bracket assembly removal</b>" on page 4-130.</li> <li>3. Replace the RFID UHF option.</li> </ol>
44.12	RFID Error	Subcommand appears truncated	
44.13	RFID Error	Subcommand appears longer than expected	
44.14	RFID Error	Subcommand field value was invalid	
44.15	RFID Error	Invalid subcommand format (invalid magic byte)	
44.16	RFID Error	Subcommand format valid but not supported	
44.17	RFID Error	Illegal chars in subcommand for specified format	
44.18	RFID Error	Invalid op code	
44.19	RFID Error	Valid but unsupported op code	
44.20	RFID Error	Invalid protocol	
44.21	RFID Error	Valid but unsupported protocol	
44.22	RFID Error	Unsupported option supplied for operation	
44.23	RFID Error	Invalid ID length	
44.24	RFID Error	Invalid ID bit pattern	
44.25	RFID Error	Too many tags on page (too many means more than one)	

Error code or message	Error contents	Description/Action	Possible repair actions
44.26	RFID Error	Based on tag location parameters: tag is not compatible with printer	<ol style="list-style-type: none"> <li>1. These error codes most likely indicate a problem with the customer's datastream, and not the RFID Option itself. Ensure there is nothing wrong with the customer's datastream.</li> <li>2. Check the RFID firmware card, RFID interface card, RFID cable, and RFID option for correct installation. Go to <b>“High capacity input tray (HCIT) pick arm bracket assembly removal” on page 4-130.</b></li> <li>3. Replace the RFID UHF option.</li> </ol>
44.27	RFID Error	Unsupported SA Code	
44.28	RFID Error	Invalid Power setting	
44.29	RFID Error	Unsupported Feature	
44.31	RFID Error	Generic run-time reader error	
44.32	RFID Error	Reader response timeout	
44.33	RFID Error	Garbled or short response from reader	
44.34	RFID Error	Read/Verify operation failed (tag data from reader != expected value)	<ol style="list-style-type: none"> <li>1. Retest using new RFID media</li> <li>2. Check the RFID firmware card, RFID interface card, RFID cable, and RFID option for correct installation. Go to <b>“High capacity input tray (HCIT) pick arm bracket assembly removal” on page 4-130.</b></li> <li>3. Replace the RFID UHF option.</li> </ol>
44.35	RFID Error	Invalid RFID region	<ol style="list-style-type: none"> <li>1. Check the RFID firmware card, RFID interface card, RFID cable, and RFID option for correct installation. Go to <b>“High capacity input tray (HCIT) pick arm bracket assembly removal” on page 4-130.</b></li> <li>2. Replace the RFID UHF option.</li> </ol>

Error code or message	Error contents	Description/Action	Possible repair actions
44.36	RFID Error	Invalid X/Y Position	<ol style="list-style-type: none"> <li>1. This error code most likely indicates a problem with the customer's datastream, and not the RFID Option itself. Ensure there is nothing wrong with the customer's datastream.</li> <li>2. Check the RFID firmware card, RFID interface card, RFID cable, and RFID option for correct installation. Go to <b>“High capacity input tray (HCIT) pick arm bracket assembly removal” on page 4-130.</b></li> <li>3. Replace the RFID UHF option.</li> </ol>
42.XY	Cartridge Region Mismatch	<p>This IR is displayed when the printer detects that the installed cartridge has a region that differs from the below options. To clear this IR, the printer cartridge must be replaced with one that has a proper region.</p> <p>X and Y can have the following values:</p> <ul style="list-style-type: none"> <li>0 : Worldwide region or Undefined region</li> <li>1 : America</li> <li>2 : EMEA</li> <li>3 : Asia</li> <li>4 : Latin America</li> <li>9 : Invalid region</li> </ul>	Install a new toner cartridge that matches the correct regional specification.
50	PPDS Font Error	<p>This message displays when the PPDS interpreter has encountered a font error.</p> <p><b>Note:</b> This error may only occur when the printer is formatting PPDS print data.</p>	<p>The following actions may be taken:</p> <ul style="list-style-type: none"> <li>• Press  to clear the message and continue processing the job.</li> <li>• Press  until Busy/Waiting appears. The following are available: <ul style="list-style-type: none"> <li>- Cancel Job</li> <li>- Reset Printer</li> <li>- Reset Active Bin</li> </ul> </li> </ul>
51	Defective Flash	This message displays when the printer detects a defective flash. This error may occur at power on, or during flash format and write operations.	Press  to clear the message. The flash is marked as bad and normal operation continues. Flash operations are not allowed until the problem is resolved.

Error code or message	Error contents	Description/Action	Possible repair actions
52	Flash Full	This message displays when the printer detects an unformatted flash at power on.	Press <input checked="" type="checkbox"/> to clear the message. The flash is marked as bad and normal operation continues. Flash operations are not allowed until the flash is formatted.
54	Serial Option [x] Error	<p>This IR is displayed when a serial error (framing, parity or overrun) has been detected on the specified optional serial port. This usually indicates that the serial port has not been set up correctly.</p> <p>Once a host interface error has been displayed for the first time, reporting of further host interface errors for the associated port is suppressed until the interface parameters are changed for the associated, or the machine is powered off.</p>	Go to network service check. See <b>“Network service check” on page 2-177.</b>
54	Std Network Software Error	This error displays when a network port is detected, but the printer cannot establish communications with it.	<p>The following actions may be taken:</p> <ul style="list-style-type: none"> <li>• Press <input checked="" type="checkbox"/> to clear the message and continue printing. The job may not print correctly.</li> <li>• Program new firmware for the network interface. Reset the printer.</li> </ul>
54	Network [x] Software Error	This error displays when a network port is detected, but the printer cannot establish communications with it.	<p>The following actions may be taken:</p> <ul style="list-style-type: none"> <li>• Press <input checked="" type="checkbox"/> to clear the message and continue printing. The job may not print correctly.</li> <li>• Program new firmware for the network interface.</li> <li>• Reset the printer.</li> </ul>
55	Unsupported Option in Slot [x]	An unsupported option is installed in the specified solutions port. Power off the printer and remove the unsupported option in the specified slot.	Remove unsupported option.
56	Parallel Port [x] Disabled	This error displays when data is sent to the printer across an optional parallel port, but the port has been disabled. Once this message displays, reporting of further errors is suppressed until the menus are entered, or the printer is reset.	Go to network service check. See <b>“Network service check” on page 2-177.</b>

Error code or message	Error contents	Description/Action	Possible repair actions
56	Serial Port [x] Disabled	This error displays when data is sent to the printer across an serial port, but the port has been disabled. Once this message displays, reporting of further errors is suppressed until the menus are entered, or the printer is reset.	Go to network service check. See <b>“Network service check” on page 2-177.</b>
56	Standard USB Port Disabled	Displayed when status is requested over the USB port, but the port has been disabled. Once the error has been displayed for the first time, reporting of further errors is suppressed until the menus are entered or the printer is reset.	The following actions may be taken: <ul style="list-style-type: none"> <li>• Press  to clear the message. The printer discards any data received on the USB port.</li> <li>• Press  until Busy/Waiting appears. The following are available: <ul style="list-style-type: none"> <li>- Reset Printer</li> </ul> Reset Active Bin</li> </ul>
56	USB Port [x] Disabled	Displayed when status is requested over the USB port, but the port has been disabled. Once the error has been displayed for the first time, reporting of further errors is suppressed until the menus are entered or the printer is reset.	The following actions may be taken: <ul style="list-style-type: none"> <li>• Press  to clear the message. The printer discards any data received on the USB port.</li> <li>• Press  until Busy/Waiting appears. The following are available: <ul style="list-style-type: none"> <li>- Reset Printer</li> </ul> Reset Active Bin</li> </ul>
58	Invalid Tray Configuration	Either no input trays or there are optional trays above the RFID option.	<ol style="list-style-type: none"> <li>1. Ensure the RFID option is in first position under printer and that there is at least one input tray beneath the RFID option.</li> <li>2. Check the RFID firmware card, RFID interface card, RFID cable, and RFID option for correct installation. Go to <b>“High capacity input tray (HCIT) pick arm bracket assembly removal” on page 4-130.</b></li> <li>3. Replace the RFID UHF option.</li> </ol>
58	Too Many Bins Attached	This error code displays when too many bins are attached to the printer.	<ol style="list-style-type: none"> <li>1. Turn off and unplug the printer.</li> <li>2. Remove the excess bins.</li> <li>3. Plug in the printer, and turn it on.</li> </ol>



Error code or message	Error contents	Description/Action	Possible repair actions
58	Too Many Disks Installed	This error code displays when too many disks are attached to the printer.	<ol style="list-style-type: none"> <li>1. Turn off and unplug the printer.</li> <li>2. Remove the excess disks.</li> <li>3. Plug in the printer, and turn it on.</li> </ol>
58	Too Many Flash Options	<p>This error code displays when too many user flash memory options or too many optional firmware cards have been installed.</p> <p>User can power off and remove extra flash options.</p>	<ol style="list-style-type: none"> <li>1. Turn off and unplug the printer.</li> <li>2. Remove the excess flash memory.</li> <li>3. Plug in the printer, and turn it on.</li> </ol>
58	Too Many Trays Attached	<p>This error code displays when too many input trays are attached to the printer.</p> <p><b>Note:</b> With the RFID option attached, the maximum number of trays is three. Without the RFID option attached, the maximum number is four.</p>	<ol style="list-style-type: none"> <li>1. Turn off and unplug the printer.</li> <li>2. Remove the excess trays.</li> <li>3. Plug in the printer, and turn it on.</li> </ol>
59	Incompatible Duplex	<p>An incompatible duplex option is installed.</p> <p>Remove the incompatible duplex option and press <input checked="" type="checkbox"/> to clear the message.</p> <p><b>Note:</b> If the user installed the incompatible device to satisfy a Check Device Connections/reattach message, the user should reinstall an associated compatible option or hot unplug the option.</p>	<ol style="list-style-type: none"> <li>1. Turn off and unplug the printer.</li> <li>2. Remove the incompatible external duplex unit assembly.</li> <li>3. Plug in the printer, and turn it on.</li> </ol>
59	Incompatible Envelope Feeder	<p>An incompatible envelope feeder is installed.</p> <p>Remove the incompatible feeder and press <input checked="" type="checkbox"/> to clear the message.</p> <p><b>Note:</b> If the user installed the incompatible device to satisfy a Check Device Connections/reattach message, the user should reinstall an associated compatible option or hot unplug the option.</p>	<ol style="list-style-type: none"> <li>1. Turn off and unplug the printer.</li> <li>2. Remove the incompatible envelope feeder.</li> <li>3. Plug in the printer, and turn it on.</li> </ol>

Error code or message	Error contents	Description/Action	Possible repair actions
59	Incompatible Output Bin [x]	<p>An incompatible output bin is installed. For Output Bin x, x=1, 2, or 3.</p> <p>Remove the incompatible output bin and press <input checked="" type="checkbox"/> to clear the message.</p> <p><b>Note:</b> If the user installed the incompatible device to satisfy a Check Device Connections/reattach message, the user should reinstall an associated compatible option or hot unplug the option.</p>	<ol style="list-style-type: none"> <li>1. Turn off and unplug the printer.</li> <li>2. Remove the incompatible output option.</li> <li>3. Plug in the printer, and turn it on.</li> </ol>
59	Incompatible Tray [x]	<p>An incompatible tray is installed. For Tray x, x= 2, 3, 4, or 5.</p> <p>Remove the incompatible tray and press <input checked="" type="checkbox"/> to clear the message.</p> <p><b>Note:</b> If the user installed the incompatible device to satisfy a Check Device Connections/reattach message, the user should reinstall an associated compatible option or hot unplug the option.</p>	<ol style="list-style-type: none"> <li>1. Turn off and unplug the printer.</li> <li>2. Remove the incompatible trays.</li> <li>3. Plug in the printer, and turn it on.</li> </ol>
61	Defective Disk	<p>This error code displays when the printer detects a defective disk. This error may occur at power on or during disk format and write operations. While this message displays.</p>	<p>press <input checked="" type="checkbox"/> to clear the message. The disk is marked defective and normal printer operations continue. Disk operations are not allowed with a defective disk. The Format Disk menu is not shown.</p>
62	Disk Full	<p>This error code displays when there is not enough free space on the disk to hold the resources that have been requested to be written to the disk. This message displays for both resource and PostScript Disk operators when the disk is full.</p>	TBD
80	Routine Maintenance Needed	<p>The operator panel displays this message at each 300K page count interval. It is necessary to replace the fuser assembly, transfer roller, charge roll, and pick rolls at this interval to maintain the print quality and reliability of the printer. The parts are available as a maintenance kit. For more information, go to <b>“Scheduled maintenance” on page 6-2.</b></p>	<p>Scheduled maintenance required.</p> <p>Refer to chapter 6.</p> <p>Go to <b>“Preventive maintenance” on page 6-1.</b></p>

Error code or message	Error contents	Description/Action	Possible repair actions
88	Cartridge Low	This IR is displayed when cartridge low occurs and the cartridge low alarm is activated. If cartridge alarm is not activated, this is not an intervention condition.	Replace the print cartridge.
88	Cartridge Nearly Low	This IR is displayed when cartridge low occurs and the cartridge low alarm is activated. If cartridge alarm is not activated, this is not an intervention condition.	Replace the print cartridge.
88	Replace Cartridge	This IR is displayed when toner cartridge is exhausted/empty.	Replace the print cartridge.

## Error code table 1

Error code or message	Error contents	Description/Action	Possible repair actions
200.00	Sensor (input) area jam	The media is jammed in the sensor (input) area.	1. Fan the media and check for obstructions. 2. Go to sensor (input) service check. See <b>“Sensor (input) service check” on page 2-126.</b>
200.01	Sensor (input) lingering jam Source = MPF, duplex or envelope feeder	The media reached the sensor (input) but did not clear it within the specified time.	1. Fan the media and check for obstructions. 2. Go to sensor (input) lingering jam service check. See <b>“Sensor (input) lingering jam service check.” on page 2-132.</b>
200.02	Sensor (input) lingering jam	The media reached the sensor (input) but did not clear it within the specified time.	1. Fan the media and ensure it is properly installed. 2. Go to sensor (input) lingering jam service check. See <b>“Sensor (input) lingering jam service check.” on page 2-132.</b>
200.04	Sensor (input) early jam	The media reached the sensor (input) sooner than the specified time. Wrong config ID causes engine to assume 500 paper path on 250 model.	1. Fan the media and ensure it is properly installed. 2. Go to sensor (input) early jam service check. See <b>“Sensor (input) early jam service check” on page 2-133.</b>
200.06	Sensor (input) early jam	The sensor (input) rebounded once the trailing edge of the media passed.	Go to sensor (input) service check. See <b>“Sensor (input) service check” on page 2-126.</b>
200.07	Sensor (input) late jam Source = input option tray	The media is late reaching the sensor (input) within the specified time.	Go to sensor (input) late jam service check. See <b>“Sensor (input) late jam service check.” on page 2-129.</b>
200.08	Sensor (input) early jam	The media reaches the sensor (input) sooner than the specified time.	1. Fan the media and ensure it is properly installed. 2. Go to sensor (input) early jam service check. See <b>“Sensor (input) early jam service check” on page 2-133.</b>

Error code or message	Error contents	Description/Action	Possible repair actions
200.09	Printhead laser start failure	The printhead laser start process failed because it did not receive proper feedback signal from the printhead motor.	<ol style="list-style-type: none"> <li>1. Check all connections on the printhead.</li> <li>2. Check all connections on the main drive motor assembly.</li> <li>3. Replace the main drive motor assembly if problem remains. Go to <b>“Output cover assembly removal (T650, T652, T654)” on page 4-54.</b></li> </ol>
200.10	Printhead motor synchronization error	The printhead motor is not synchronized when media reaches the sensor (input).	<ol style="list-style-type: none"> <li>1. Remove all media present in media path.</li> <li>2. Check all connections on the printhead.</li> <li>3. Check all connections on the system card assembly.</li> <li>4. Replace the printhead if problem remains. Go to <b>“Printhead assembly removal (T650)” on page 4-60</b> or <b>“Printhead assembly removal (T652, T654)” on page 4-61.</b></li> </ol>
200.11	Printhead polygon mirror synchronization error	The printhead polygon mirror motor becomes un-synchronized when the media reaches the sensor (input).	<ol style="list-style-type: none"> <li>1. Remove all media present in media path.</li> <li>2. Check all connections on the printhead.</li> <li>3. Check all connections on the system card assembly.</li> <li>4. Replace the printhead if problem remains. Go to <b>“Printhead assembly removal (T650)” on page 4-60</b> or <b>“Printhead assembly removal (T652, T654)” on page 4-61.</b></li> </ol>
200.12	Laser power signal error	The printhead laser power signal has failed	<ol style="list-style-type: none"> <li>1. Remove all media present in media path.</li> <li>2. Check all connections on the printhead.</li> <li>3. Check all connections on the system card assembly.</li> <li>4. Replace the printhead if problem remains. Go to <b>“Printhead assembly removal (T650)” on page 4-60</b> or <b>“Printhead assembly removal (T652, T654)” on page 4-61</b></li> <li>5. Replace the system card if problem remains. Go to <b>“System card assembly removal (T650, T652, T654, T656)” on page 4-76.</b></li> </ol>

Error code or message	Error contents	Description/Action	Possible repair actions
200.13	Sensor (input) static jam	Media remains on the sensor (input) during the warm up sequence.	Go to sensor (input) static jam service check. See <b>“Sensor (input) static jam service check”</b> on page 2-135.
200.14	Sensor (input) early jam	The media reached the sensor (input) sooner than the specified time.	Go to sensor (input) early jam service check. See <b>“Sensor (input) early jam service check”</b> on page 2-133.
200.15	Laser power did not settle	Laser circuit failure on printhead or system card assembly.	<ol style="list-style-type: none"> <li>1. Remove all media present in media path.</li> <li>2. Check all connections on the printhead.</li> <li>3. Check all connections on the system card assembly.</li> <li>4. Replace the printhead if problem remains. Go to <b>“Printhead assembly removal (T650)”</b> on page 4-60 or <b>“Printhead assembly removal (T652, T654)”</b> on page 4-61</li> <li>5. Replace the system card if problem remains. Go to <b>“System card assembly removal (T650, T652, T654, T656)”</b> on page 4-76.</li> </ol>
200.16	Main drive motor assembly load error	The main drive motor assembly has failed or caused high mechanical load due to paper jam or bind.	<ol style="list-style-type: none"> <li>1. Remove all media present in media path.</li> <li>2. Check all connections on the main drive motor assembly.</li> <li>3. Check all connections on the system card assembly.</li> <li>4. Replace the main drive motor assembly if problem remains. Go to <b>“Output cover assembly removal (T650, T652, T654)”</b> on page 4-54.</li> </ol>
200.17	Sensor (input) lingering jam Source = Tray 1 Tray level= Not Low	The media reached the sensor (input) but did not clear it within the specified time.	Go to sensor (input) lingering jam service check. See <b>“Sensor (input) lingering jam service check.”</b> on page 2-132.
200.18	Sensor (input) lingering jam Source = Tray 1 Tray level = Low	The media reached the sensor (input) but did not clear it within the specified time.	Go to sensor (input) lingering jam service check. See <b>“Sensor (input) lingering jam service check.”</b> on page 2-132.

Error code or message	Error contents	Description/Action	Possible repair actions
200.19	Sensor (input) lingering jam Source = Tray 1 Tray level = Empty	The media reached the sensor (input) but did not clear it within the specified time.	Go to sensor (input) lingering jam service check. See <b>“Sensor (input) lingering jam service check.”</b> on page 2-132.
200.27	Sensor (input) lingering jam Source = Tray 2 Tray level = Not Low	The media reached the sensor (input) but did not clear it within the specified time.	Go to sensor (input) lingering jam service check. See <b>“Sensor (input) lingering jam service check.”</b> on page 2-132.
200.28	Sensor (input) lingering jam Source = Tray 2 Tray level = Low	The media reached the sensor (input) but did not clear it within the specified time.	Go to sensor (input) lingering jam service check. See <b>“Sensor (input) lingering jam service check.”</b> on page 2-132.
200.29	Sensor (input) lingering jam Source = Tray 2 Tray level = Empty	The media reached the sensor (input) but did not clear it within the specified time.	Go to sensor (input) lingering jam service check. See <b>“Sensor (input) lingering jam service check.”</b> on page 2-132.
200.32	Operator panel door assembly switch failure	Operator panel door assembly not fully closed. Interlock switch not functioning correctly.	<ol style="list-style-type: none"> <li>1. Ensure that the operator panel door assembly is fully closed.</li> <li>2. Check operator panel door assembly for damage.</li> <li>3. Check interlock switch (in left operator panel hinge) for damage.</li> <li>4. Check all connections on the system card assembly.</li> </ol>
200.33	Sensor (input) early jam	The media reached the sensor (input) sooner than the specified time. Wrong config ID causes engine to assume 500 paper path on 250 model.	<ol style="list-style-type: none"> <li>1. Fan the media and ensure it is properly installed.</li> <li>2. Go to sensor (input) early jam service check.</li> </ol> See <b>“Sensor (input) early jam service check”</b> on page 2-133.
200.34	Sensor (toner empty) failure	The sensor (toner empty) has failed or is not sensing the pulse wheel on the print cartridge.	<ol style="list-style-type: none"> <li>1. Inspect print cartridge pulse wheel for damage and replace if needed.</li> <li>2. Check the sensor (toner empty) for proper operation.</li> </ol> See <b>“Sensor (toner empty) service check”</b> on page 2-155.
200.37	Sensor (input) lingering jam Source = Tray 3 Tray level= Not Low	The media reached the sensor (input) but did not clear it within the specified time.	Go to sensor (input) lingering jam service check. See <b>“Sensor (input) lingering jam service check.”</b> on page 2-132.

Error code or message	Error contents	Description/Action	Possible repair actions
200.38	Sensor (input) lingering jam Source = Tray 3 Tray level = Low	The media reached the sensor (input) but did not clear it within the specified time.	Go to sensor (input) lingering jam service check. See <b>“Sensor (input) lingering jam service check.” on page 2-132.</b>
200.39	Sensor (input) lingering jam Source = Tray 3 Tray level = Empty	The media reached the sensor (input) but did not clear it within the specified time.	Go to sensor (input) lingering jam service check. See <b>“Sensor (input) lingering jam service check.” on page 2-132.</b>
200.47	Sensor (input) lingering jam Source = Tray 4 Tray level = Not Low	The media reached the sensor (input) but did not clear it within the specified time.	Go to sensor (input) lingering jam service check. See <b>“Sensor (input) lingering jam service check.” on page 2-132.</b>
200.48	Sensor (input) lingering jam Source = Tray 4 Tray level = Low	The media reached the sensor (input) but did not clear it within the specified time.	Go to sensor (input) lingering jam service check. See <b>“Sensor (input) lingering jam service check.” on page 2-132.</b>
200.49	Sensor (input) lingering jam Source = Tray 4 Tray level = Empty	The media reached the sensor (input) but did not clear it within the specified time.	Go to sensor (input) lingering jam service check. See <b>“Sensor (input) lingering jam service check.” on page 2-132.</b>
200.57	Sensor (input) lingering jam Source = Tray 5 Tray level = Not Low	The media reached the sensor (input) but did not clear it within the specified time.	Go to sensor (input) lingering jam service check. See <b>“Sensor (input) lingering jam service check.” on page 2-132.</b>
200.58	Sensor (input) lingering jam Source = Tray 5 Tray level = Low	The media reached the sensor (input) but did not clear it within the specified time.	Go to sensor (input) lingering jam service check. See <b>“Sensor (input) lingering jam service check.” on page 2-132.</b>
200.59	Sensor (input) lingering jam Source = Tray 5 Tray level = Empty	The media reached the sensor (input) but did not clear it within the specified time.	Go to sensor (input) lingering jam service check. See <b>“Sensor (input) lingering jam service check.” on page 2-132.</b>
201.00	Sensor (fuser output) area jam. Type 1 fuser	The media is jammed in the sensor (fuser output) area.	Go to sensor (fuser output) service check. See <b>“Sensor (fuser output) service check” on page 2-126.</b>



Error code or message	Error contents	Description/Action	Possible repair actions
201.01	Main drive motor assembly load error. Type 1 fuser	The main drive motor assembly has failed or caused high mechanical load due to paper jam or bind.	<ol style="list-style-type: none"> <li>1. Check all connections on the main drive motor assembly.</li> <li>2. Check all connections on the system card assembly.</li> <li>3. Replace the main drive motor assembly if problem remains. Go to <b>“Output cover assembly removal (T650, T652, T654)” on page 4-54.</b></li> </ol>
201.02	Sensor (fuser output) late jam. Type 1 fuser	The media is late reaching the sensor (fuser output) within the specified time.	<p>Go to sensor (fuser output) late jam service check.</p> <p>See <b>“Sensor (fuser output) late jam service check.” on page 2-135.</b></p> <p>If problem remains, a type 2 fuser can be installed.</p>
201.03	Image data did not start in time Type 1 fuser	Printhead write failure	<ol style="list-style-type: none"> <li>1. Check all connections on the printhead assembly</li> <li>2. Check all connections on the system card assembly.</li> <li>3. Replace the printhead assembly if problem remains.</li> <li>4. Replace the system card assembly if problem remains. Go to <b>“System card assembly removal (T650, T652, T654, T656)” on page 4-76.</b></li> </ol>
201.04	Sensor (narrow media) late jam Type 1 fuser	The expected wide media is late reaching the sensor (narrow media) within the specified time.	<p>Go to sensor (narrow media) late jam service check.</p> <p>See <b>“Sensor (narrow media) late jam service check.” on page 2-139.</b></p>
201.06	Sensor (narrow media) late jam Type 1 fuser	The expected wide media is late reaching the sensor (narrow media) within the specified time.	<p>Go to sensor (narrow media) late jam service check.</p> <p>See <b>“Sensor (narrow media) late jam service check.” on page 2-139.</b></p>
201.07	Sensor (fuser output) late jam Type 1 fuser	The media is late reaching the sensor (fuser output) within the specified time.	<p>Go to sensor (fuser output) late jam service check.</p> <p>See <b>“Sensor (fuser output) late jam service check.” on page 2-135.</b></p>
201.25	Sensor (fuser output) area jam. Type 2 fuser	The media is jammed in the sensor (fuser output) area.	<p>Go to sensor (fuser output) service check.</p> <p>See <b>“Sensor (fuser output) late jam service check.” on page 2-135.</b></p>

Error code or message	Error contents	Description/Action	Possible repair actions
201.26	Main drive motor assembly load error. Type 2 fuser	The main drive motor assembly has failed or caused high mechanical load due to paper jam or bind.	<ol style="list-style-type: none"> <li>1. Check all connections on the main drive motor assembly.</li> <li>2. Check all connections on the system card assembly.</li> <li>3. Replace the main drive motor assembly if problem remains. Go to <b>“Output cover assembly removal (T650, T652, T654)” on page 4-54.</b></li> </ol>
201.27	Sensor (fuser output) late jam. Type 2 fuser	The media is late reaching the sensor (fuser output) within the specified time.	<p>Go to sensor (fuser output) late jam service check.</p> <p>See <b>“Sensor (fuser output) late jam service check.” on page 2-135.</b></p> <p>If problem remains, a type 2 fuser can be installed.</p>
201.28	Image data did not start in time Type 2 fuser	Printhead write failure	<ol style="list-style-type: none"> <li>1. Check all connections on the printhead assembly</li> <li>2. Check all connections on the system card assembly.</li> <li>3. Replace the printhead assembly if problem remains.</li> <li>4. Replace the system card assembly if problem remains. Go to <b>“System card assembly removal (T650, T652, T654, T656)” on page 4-76.</b></li> </ol>
201.29	Sensor (narrow media) late jam Type 2 fuser	The expected wide media is late reaching the sensor (narrow media) within the specified time.	<p>Go to sensor (narrow media) late jam service check.</p> <p>See <b>“Sensor (narrow media) late jam service check.” on page 2-139.</b></p>
201.30	Operator panel door assembly interlock switch failure Type 2 fuser	The printer detected that the operator panel door interlock switch did not cycle prior to printer restart.	<ol style="list-style-type: none"> <li>1. Remove all media present in media path.</li> <li>2. Ensure that the operator panel door assembly is fully open then fully closed.</li> <li>3. Check operator panel door assembly for damage.</li> <li>4. Check interlock switch (in left operator panel hinge) for damage.</li> <li>5. Check all connections on the system card assembly.</li> </ol>
201.31	Sensor (narrow media) late jam Type 2 fuser	The expected wide media is late reaching the sensor (narrow media) within the specified time.	<p>Go to sensor (narrow media) late jam service check.</p> <p>See <b>“Sensor (narrow media) late jam service check.” on page 2-139.</b></p>

Error code or message	Error contents	Description/Action	Possible repair actions
201.32	Sensor (fuser output) late jam Type 2 fuser	The media is late reaching the sensor (fuser output) within the specified time.	Go to sensor (fuser output) late jam service check. See <b>“Sensor (fuser output) late jam service check.”</b> on page 2-135.
201.50	Sensor (fuser output) late jam Type 1 fuser Fuser page count has exceeded life.	The media is late reaching the sensor (fuser output) within the specified time.	Go to sensor (fuser output) service check. See <b>“Sensor (fuser output) service check”</b> on page 2-126.
201.51	Main drive motor assembly load error. Type 1 fuser Fuser page count has exceeded life.	The main drive motor assembly has failed or caused high mechanical load due to paper jam or bind.	<ol style="list-style-type: none"> <li>1. Check all connections on the main drive motor assembly.</li> <li>2. Check all connections on the system card assembly.</li> <li>3. Replace the main drive motor assembly if problem remains. Go to <b>“Output cover assembly removal (T650, T652, T654)”</b> on page 4-54.</li> </ol>
201.52	Sensor (fuser output) late jam Type 1 fuser Fuser page count has exceeded life.	The media is late reaching the sensor (fuser output) within the specified time.	Go to sensor (fuser output) late jam service check. See <b>“Sensor (fuser output) late jam service check.”</b> on page 2-135. If problem remains, a type 2 fuser can be installed.
201.53	Image data did not start in time Type 1 fuser Fuser page count has exceeded life	Printhead write failure	<ol style="list-style-type: none"> <li>1. Check all connections on the printhead assembly</li> <li>2. Check all connections on the system card assembly.</li> <li>3. Replace the printhead assembly if problem remains.</li> <li>4. Replace the system card assembly if problem remains. Go to <b>“System card assembly removal (T650, T652, T654, T656)”</b> on page 4-76.</li> </ol>
201.54	Sensor (narrow media) late jam Type 1 fuser Fuser page count has exceeded life	The media is late reaching the sensor (narrow media) within the specified time.	Go to sensor (narrow media) late jam service check. See <b>“Sensor (narrow media) late jam service check.”</b> on page 2-139.

Error code or message	Error contents	Description/Action	Possible repair actions
201.55	Operator panel door assembly interlock switch open failure Type 1 fuser Fuser page count has exceeded life	The printer detected that the switch (operator panel door interlock) did not cycle prior to printer restart.	<ol style="list-style-type: none"> <li>1. Remove all media present in media path.</li> <li>2. Ensure that the operator panel door assembly is fully open then fully closed.</li> <li>3. Check operator panel door assembly for damage.</li> <li>4. Check interlock switch (in left operator panel hinge) for damage.</li> <li>5. Check all connections on the system card assembly.</li> </ol>
201.56	Sensor (narrow media) late jam Type 1 fuser Fuser page count has exceeded life.	The media is late reaching the sensor (narrow media) within the specified time.	Go to sensor (narrow media) late jam service check. See <b>“Sensor (narrow media) late jam service check.”</b> on page 2-139.
201.57	Sensor (fuser output) late jam Type 1 fuser Fuser page count has exceeded life	The media is late reaching the sensor (fuser output) within the specified time.	Go to sensor (fuser output) late jam service check. See <b>“Sensor (fuser output) late jam service check.”</b> on page 2-135.
201.75	Sensor (fuser output) late jam Type 2 fuser Fuser page count has exceeded life.	The media is late reaching the sensor (fuser output) within the specified time.	Go to sensor (fuser output) late jam service check. See <b>“Sensor (fuser output) late jam service check.”</b> on page 2-135.
201.76	Main drive motor assembly load error. Type 2 fuser Fuser page count has exceeded life.	The main drive motor assembly has failed or caused high mechanical load due to paper jam or bind.	<ol style="list-style-type: none"> <li>1. Remove all media present in media path.</li> <li>2. Check all connections on the main drive motor assembly.</li> <li>3. Check all connections on the system card assembly.</li> <li>4. Replace the main drive motor assembly if problem remains. Go to <b>“Output cover assembly removal (T650, T652, T654)”</b> on page 4-54.</li> </ol>
201.77	Sensor (fuser output) late jam Type 2 fuser Fuser page count has exceeded life.	The media is late reaching the sensor (fuser output) within the specified time.	Go to sensor (fuser output) late jam service check. See <b>“Sensor (fuser output) late jam service check.”</b> on page 2-135.

Error code or message	Error contents	Description/Action	Possible repair actions
201.78	Image data did not start in time Type 2 fuser Fuser page count has exceeded life	Printhead write failure	<ol style="list-style-type: none"> <li>1. Check all connections on the printhead assembly</li> <li>2. Check all connections on the system card assembly.</li> <li>3. Replace the printhead assembly if problem remains.</li> <li>4. Replace the system card assembly if problem remains. Go to <b>“System card assembly removal (T650, T652, T654, T656)” on page 4-76.</b></li> </ol>
201.79	Sensor (narrow media) late jam Type 2 fuser Fuser page count has exceeded life	The media is late reaching the sensor (narrow media) within the specified time.	Go to sensor (narrow media) late jam service check. See <b>“Sensor (narrow media) late jam service check.” on page 2-139.</b>
201.80	Operator panel door assembly interlock switch open failure Type 2 fuser Fuser page count has exceeded life	The printer detected that the switch (operator panel door interlock) did not cycle prior to printer restart.	<ol style="list-style-type: none"> <li>1. Remove all media present in media path.</li> <li>2. Ensure that the operator panel door assembly is fully open then fully closed.</li> <li>3. Check operator panel door assembly for damage.</li> <li>4. Check interlock switch (in left operator panel hinge) for damage.</li> <li>5. Check all connections on the system card assembly.</li> </ol>
201.81	Sensor (narrow media) late jam Type 2 fuser Fuser page count has exceeded life.	The media is late reaching the sensor (narrow media) within the specified time.	Go to sensor (narrow media) late jam service check. See <b>“Sensor (narrow media) late jam service check.” on page 2-139.</b>
201.82	Sensor (fuser output) late jam Type 2 fuser Fuser page count has exceeded life	The media is late reaching the sensor (fuser output) within the specified time.	Go to sensor (fuser output) late jam service check. See <b>“Sensor (fuser output) late jam service check.” on page 2-135.</b>

Error code or message	Error contents	Description/Action	Possible repair actions
202.00	Paper jam around fuser exit or redrive area. Type 1 fuser	Page may be jammed in fuser exit or redrive area.	<ol style="list-style-type: none"> <li>1. Remove all media present in media path.</li> <li>2. Check media for proper installation.</li> <li>3. Check for obstructions in media path.</li> <li>4. Go to sensor (fuser output) service check. See <b>“Sensor (fuser output) service check” on page 2-126.</b></li> <li>5. Go to sensor (narrow media) service check. See <b>“Sensor (narrow media) service check” on page 2-127.</b></li> </ol>
202.01	Sensor (fuser output) lingering jam. Destination is standard bin. Type 1 fuser	Media reached the sensor (fuser output) but did not clear it in the specified time. and Media did not reach the sensor (narrow media)	Go to sensor (fuser output) lingering jam service check. See <b>“Sensor (fuser output) lingering jam service check.” on page 2-137.</b>
202.02	Sensor (fuser output) lingering jam. Type 1 fuser	Media reached the sensor (fuser output) but did not clear it in the specified time.	Go to sensor (fuser output) lingering jam service check. See <b>“Sensor (fuser output) lingering jam service check.” on page 2-137.</b>
202.03	Sensor (narrow media) static jam Type 1 fuser	Media remains on the sensor (narrow media) during the warm up sequence.	Go to sensor (narrow media) static jam service check. See <b>“Sensor (narrow media) static jam service check” on page 2-140.</b>
202.04	Sensor (fuser output) bounce Type 1 fuser	The sensor (fuser output) rebounded once the trailing edge of the media passed.	Go to sensor (fuser output) service check. See <b>“Sensor (fuser output) service check” on page 2-126.</b>
202.06	Sensor (fuser output) static jam Type 1 fuser	Media remains on the sensor (fuser output) during the warm up sequence.	Go to sensor (fuser output) static jam service check. See <b>“Sensor (fuser output) static jam service check” on page 2-138.</b>
202.07	Sensor (fuser output) lingering jam. Type 1 fuser	Media reached the sensor (fuser output) but did not clear it in the specified time.	Go to sensor (fuser output) lingering jam service check. See <b>“Sensor (fuser output) lingering jam service check.” on page 2-137.</b>
202.09	Sensor (fuser output) lingering jam. Type 1 fuser	Media reached the sensor (fuser output) but did not clear it in the specified time.	Go to sensor (fuser output) lingering jam service check. See <b>“Sensor (fuser output) lingering jam service check.” on page 2-137.</b>

Error code or message	Error contents	Description/Action	Possible repair actions
202.10	Sensor (fuser output) lingering jam. Destination is output option. Type 1 fuser	Media reached the sensor (fuser output) but did not clear it in the specified time. and Media did not reach the sensor (narrow media)	Go to sensor (fuser output) lingering jam service check. See <b>“Sensor (fuser output) lingering jam service check.”</b> on page 2-137.
202.11	Sensor (fuser output) lingering jam. Destination is standard bin. Type 1 fuser	Media reached the sensor (fuser output) but did not clear it in the specified time. and Media did reach the sensor (narrow media)	Go to sensor (fuser output) lingering jam service check. See <b>“Sensor (fuser output) lingering jam service check.”</b> on page 2-137.
202.12	Sensor (fuser output) lingering jam. Destination is output option. Type 1 fuser	Media reached the sensor (fuser output) but did not clear it in the specified time. and Media did reach the sensor (narrow media)	Go to sensor (fuser output) lingering jam service check. See <b>“Sensor (fuser output) lingering jam service check.”</b> on page 2-137.
202.13	Sensor (fuser output) static jam and Sensor (narrow media) static jam Type 1 fuser	Media remains on the sensor (fuser output) and the sensor (narrow media) during the warm up sequence.	<ol style="list-style-type: none"> <li>1. Go to sensor (fuser output) static jam service check. See <b>“Sensor (fuser output) static jam service check”</b> on page 2-138.</li> <li>2. Go to sensor (narrow media) static jam service check. See <b>“Sensor (narrow media) static jam service check”</b> on page 2-140.</li> </ol>
202.25	Paper jam around fuser exit or redrive area. Type 2 fuser	Page may be jammed in fuser exit or redrive area.	<ol style="list-style-type: none"> <li>1. Remove all media present in media path.</li> <li>2. Check media for proper installation.</li> <li>3. Check for obstructions in media path.</li> <li>4. Go to sensor (fuser output) service check.</li> <li>5. See <b>“Sensor (fuser output) service check”</b> on page 2-126.</li> <li>6. Go to sensor (narrow media) service check. See <b>“Sensor (narrow media) service check”</b> on page 2-127.</li> </ol>
202.26	Sensor (fuser output) lingering jam. Destination is standard bin. Type 2 fuser	Media reached the sensor (fuser output) but did not clear it in the specified time. and Media did not reach the sensor (narrow media)	Go to sensor (fuser output) lingering jam service check. See <b>“Sensor (fuser output) lingering jam service check.”</b> on page 2-137.

Error code or message	Error contents	Description/Action	Possible repair actions
202.27	Sensor (fuser output) lingering jam. Type 2 fuser	Media reached the sensor (fuser output) but did not clear it in the specified time.	Go to sensor (fuser output) lingering jam service check. See <b>“Sensor (fuser output) lingering jam service check.”</b> on page 2-137.
202.28	Sensor (narrow media) static jam Type 2 fuser	Media remains on the sensor (narrow media) during the warm up sequence.	Go to sensor (narrow media) static jam service check. See <b>“Sensor (narrow media) static jam service check”</b> on page 2-140.
202.29	Sensor (fuser output) bounce Type 2 fuser	The sensor (fuser output) rebounded once the trailing edge of the media passed.	Go to sensor (fuser output) service check. See <b>“Sensor (fuser output) service check”</b> on page 2-126.
202.30	Never sent the divert command to the stacker. Type 2 fuser		
202.31	Sensor (fuser output) static jam Type 2 fuser	Media remains on the sensor (fuser output) during the warm up sequence.	Go to sensor (fuser output) static jam service check. See <b>“Sensor (fuser output) static jam service check”</b> on page 2-138.
202.32	Sensor (fuser output) lingering jam. Type 2 fuser	Media reached the sensor (fuser output) but did not clear it in the specified time.	Go to sensor (fuser output) lingering jam service check. See <b>“Sensor (fuser output) lingering jam service check.”</b> on page 2-137.
202.34	Sensor (fuser output) lingering jam. Type 2 fuser	Media reached the sensor (fuser output) but did not clear it in the specified time.	Go to sensor (fuser output) lingering jam service check. See <b>“Sensor (fuser output) lingering jam service check.”</b> on page 2-137.
202.35	Sensor (fuser output) lingering jam. Destination is output option. Type 2 fuser	Media reached the sensor (fuser output) but did not clear it in the specified time. and Media did not reach the sensor (narrow media)	Go to sensor (fuser output) lingering jam service check. See <b>“Sensor (fuser output) lingering jam service check.”</b> on page 2-137.
202.36	Sensor (fuser output) lingering jam. Destination is standard bin. Type 2 fuser	Media reached the sensor (fuser output) but did not clear it in the specified time. and Media did reach the sensor (narrow media)	Go to sensor (fuser output) lingering jam service check. See <b>“Sensor (fuser output) lingering jam service check.”</b> on page 2-137.



Error code or message	Error contents	Description/Action	Possible repair actions
202.37	Sensor (fuser output) lingering jam. Destination is output option. Type 2 fuser	Media reached the sensor (fuser output) but did not clear it in the specified time. and Media did reach the sensor (narrow media)	Go to sensor (fuser output) lingering jam service check. See <b>“Sensor (fuser output) lingering jam service check.”</b> on page 2-137.
202.38	Sensor (fuser output) static jam and Sensor (narrow media) static jam Type 2 fuser	Media remains on the sensor (fuser output) and the sensor (narrow media) during the warm up sequence.	1. Go to sensor (fuser output) static jam service check. See <b>“Sensor (fuser output) static jam service check”</b> on page 2-138. 2. Go to sensor (narrow media) static jam service check. See <b>“Sensor (narrow media) static jam service check”</b> on page 2-140.
202.50	Paper jam around fuser exit or redrive area. Type 1 fuser Fuser page count has exceeded life	Page may be jammed in fuser exit or redrive area.	1. Remove all media present in media path. 2. Check media for proper installation. 3. Check for obstructions in media path. 4. Go to sensor (fuser output) service check. See <b>“Sensor (fuser output) service check”</b> on page 2-126. 5. Go to sensor (narrow media) service check. See <b>“Sensor (narrow media) service check”</b> on page 2-127.
202.51	Sensor (fuser output) lingering jam. Destination is standard bin. Type 1 fuser Fuser page count has exceeded life.	Media reached the sensor (fuser output) but did not clear it in the specified time.	Go to sensor (fuser output) lingering jam service check. See <b>“Sensor (fuser output) lingering jam service check.”</b> on page 2-137.
202.52	Sensor (fuser output) lingering jam. Type 1 fuser Fuser page count has exceeded life.	Media reached the sensor (fuser output) but did not clear it in the specified time.	Go to sensor (fuser output) lingering jam service check. See <b>“Sensor (fuser output) lingering jam service check.”</b> on page 2-137.
202.53	Sensor (narrow media) static jam Type 1 fuser Fuser page count has exceeded life.	Media remains on the sensor (narrow media) during the warm up sequence.	Go to sensor (narrow media) static jam service check. See <b>“Sensor (narrow media) static jam service check”</b> on page 2-140.

Error code or message	Error contents	Description/Action	Possible repair actions
202.54	Sensor (fuser output) bounce Type 1 fuser Fuser page count has exceeded life.	The sensor (fuser output) rebounded once the trailing edge of the media passed.	Go to sensor (fuser output) service check. See <b>“Sensor (fuser output) service check” on page 2-126.</b>
202.56	Sensor (fuser output) static jam Type 1 fuser Fuser page count has exceeded life.	Media remains on the sensor (fuser output) during the warm up sequence.	Go to sensor (fuser output) static jam service check. See <b>“Sensor (fuser output) static jam service check” on page 2-138.</b>
202.57	Sensor (fuser output) lingering jam. Type 1 fuser Fuser page count has exceeded life.	Media reached the sensor (fuser output) but did not clear it in the specified time.	Go to sensor (fuser output) lingering jam service check. See <b>“Sensor (fuser output) lingering jam service check.” on page 2-137.</b>
202.59	Sensor (fuser output) lingering jam. Type 1 fuser Fuser page count has exceeded life.	Media reached the sensor (fuser output) but did not clear it in the specified time.	Go to sensor (fuser output) lingering jam service check. See <b>“Sensor (fuser output) lingering jam service check.” on page 2-137.</b>
202.60	Sensor (fuser output) lingering jam. Destination is output option. Type 1 fuser Fuser page count has exceeded life.	Media reached the sensor (fuser output) but did not clear it in the specified time.  and Media did not reach the sensor (narrow media)	Go to sensor (fuser output) lingering jam service check. See <b>“Sensor (fuser output) lingering jam service check.” on page 2-137.</b>
202.61	Sensor (fuser output) lingering jam. Destination is standard bin. Type 1 fuser Fuser page count has exceeded life.	Media reached the sensor (fuser output) but did not clear it in the specified time.  and Media did reach the sensor (narrow media)	Go to sensor (fuser output) lingering jam service check. See <b>“Sensor (fuser output) lingering jam service check.” on page 2-137.</b>
202.62	Sensor (fuser output) lingering jam. Destination is output option. Type 1 fuser Fuser page count has exceeded life.	Media reached the sensor (fuser output) but did not clear it in the specified time.  and Media did reach the sensor (narrow media)	Go to sensor (fuser output) lingering jam service check. See <b>“Sensor (fuser output) lingering jam service check.” on page 2-137.</b>

Error code or message	Error contents	Description/Action	Possible repair actions
202.63	Sensor (fuser output) static jam and Sensor (narrow media) static jam Type 1 fuser Fuser page count has exceeded life.	Media remains on the sensor (fuser output) and the sensor (narrow media) during the warm up sequence.	<ol style="list-style-type: none"> <li>Go to sensor (fuser output) static jam service check. See <b>“Sensor (fuser output) static jam service check” on page 2-138.</b></li> <li>Go to sensor (narrow media) static jam service check. See <b>“Sensor (narrow media) static jam service check” on page 2-140.</b></li> </ol>
202.75	Paper jam around fuser exit or redrive area. Type 2 fuser Fuser page count has exceeded life.	Page may be jammed in fuser exit or redrive area.	<ol style="list-style-type: none"> <li>Remove all media present in media path.</li> <li>Check media for proper installation.</li> <li>Check for obstructions in media path.</li> <li>Go to sensor (fuser output) service check. See <b>“Sensor (fuser output) service check” on page 2-126.</b></li> <li>Go to sensor (narrow media) service check. See <b>“Sensor (narrow media) service check” on page 2-127.</b></li> </ol>
202.76	Sensor (fuser output) lingering jam. Destination is standard bin. Type 2 fuser Fuser page count has exceeded life.	Media reached the sensor (fuser output) but did not clear it in the specified time. and Media did not reach the sensor (narrow media)	Go to sensor (fuser output) lingering jam service check. See <b>“Sensor (fuser output) lingering jam service check.” on page 2-137.</b>
202.77	Sensor (fuser output) lingering jam. Type 2 fuser Fuser page count has exceeded life.	Media reached the sensor (fuser output) but did not clear it in the specified time.	Go to sensor (fuser output) lingering jam service check. See <b>“Sensor (fuser output) lingering jam service check.” on page 2-137.</b>
202.78	Sensor (narrow media) static jam Type 2 fuser Fuser page count has exceeded life.	Media remains on the sensor (narrow media) during the warm up sequence.	<ol style="list-style-type: none"> <li>Go to sensor (fuser output) static jam service check. See <b>“Sensor (fuser output) static jam service check” on page 2-138.</b></li> <li>Go to sensor (narrow media) static jam service check. See <b>“Sensor (narrow media) static jam service check” on page 2-140.</b></li> </ol>
202.79	Sensor (fuser output) bounce Type 2 fuser Fuser page count has exceeded life.	The sensor (fuser output) rebounded once the trailing edge of the media passed.	Go to sensor (fuser output) service check. See <b>“Sensor (fuser output) service check” on page 2-126.</b>

Error code or message	Error contents	Description/Action	Possible repair actions
202.81	Sensor (fuser output) static jam Type 2 fuser Fuser page count has exceeded life.	Media remains on the sensor (fuser output) during the warm up sequence.	Go to sensor (fuser output) static jam service check. See <b>“Sensor (fuser output) static jam service check” on page 2-138.</b>
202.82	Sensor (fuser output) lingering jam. Type 2 fuser Fuser page count has exceeded life.	Media reached the sensor (fuser output) but did not clear it in the specified time.	Go to sensor (fuser output) lingering jam service check. See <b>“Sensor (fuser output) lingering jam service check.” on page 2-137.</b>
202.84	Sensor (fuser output) lingering jam. Type 2 fuser Fuser page count has exceeded life.	Media reached the sensor (fuser output) but did not clear it in the specified time.	Go to sensor (fuser output) lingering jam service check. See <b>“Sensor (fuser output) lingering jam service check.” on page 2-137.</b>
202.85	Sensor (fuser output) lingering jam. Destination is output option. Type 2 fuser Fuser page count has exceeded life.	Media reached the sensor (fuser output) but did not clear it in the specified time.  and Media did not reach the sensor (narrow media)	Go to sensor (fuser output) lingering jam service check. See <b>“Sensor (fuser output) lingering jam service check.” on page 2-137.</b>
202.86	Sensor (fuser output) lingering jam. Destination is standard bin. Type 2 fuser Fuser page count has exceeded life.	Media reached the sensor (fuser output) but did not clear it in the specified time.  and Media did reach the sensor (narrow media)	Go to sensor (fuser output) lingering jam service check. See <b>“Sensor (fuser output) lingering jam service check.” on page 2-137.</b>
202.87	Sensor (fuser output) lingering jam. Destination is output option. Type 2 fuser Fuser page count has exceeded life.	Media reached the sensor (fuser output) but did not clear it in the specified time.  and Media did reach the sensor (narrow media)	Go to sensor (fuser output) lingering jam service check. See <b>“Sensor (fuser output) lingering jam service check.” on page 2-137.</b>
202.88	Sensor (fuser output) static jam and Sensor (narrow media) static jam Type 2 fuser Fuser page count has exceeded life.	Media remains on the sensor (fuser output) and the sensor (narrow media) during the warm up sequence.	1. Go to sensor (fuser output) static jam service check. See <b>“Sensor (fuser output) static jam service check” on page 2-138.</b> 2. Go to sensor (narrow media) static jam service check. See <b>“Sensor (narrow media) static jam service check” on page 2-140.</b>

Error code or message	Error contents	Description/Action	Possible repair actions
202.99	Fuser ID chip failure	The system does not recognize the ID chip on the fuser unit.	Replace the fuser unit assembly. Go to <b>“Fuser unit assembly removal (T650, T652, T654)” on page 4-23,</b>
203.00	Paper jam around redrive area.	Page may be jammed in redrive area.	<ol style="list-style-type: none"> <li>1. Remove all media present in media path.</li> <li>2. Check media for proper installation.</li> <li>3. Check for obstructions in media path.</li> <li>4. Go to sensor (fuser output) service check. See <b>“Sensor (fuser output) service check” on page 2-126.</b></li> <li>5. Go to sensor (narrow media) service check. See <b>“Sensor (narrow media) service check” on page 2-127.</b></li> </ol>
203.01	Internal duplex drive motor control failure. Internal duplex	The internal duplex drive motor does not reach the proper operating speed at the specified time.	<ol style="list-style-type: none"> <li>1. Remove all media present in media path.</li> <li>2. Check all connections on the duplex media entrance drive motor assembly.</li> <li>3. Check all connections on the system card assembly.</li> <li>4. Replace the duplex media entrance drive motor assembly if problem remains. Go to <b>“Duplex drive motor assembly removal (T652, T654)” on page 4-19.</b></li> </ol>
203.08	Redrive motor load error	The redrive motor assembly has failed or caused high mechanical load during the warm up sequence.	<ol style="list-style-type: none"> <li>1. Remove all media present in media path.</li> <li>2. Ensure that upper redrive assembly is properly installed.</li> <li>3. Check all connections on the redrive motor assembly.</li> <li>4. Check all connections on the system card assembly.</li> <li>5. Replace the redrive motor assembly if problem remains. Go to <b>“Redrive assembly removal (T650, T652, T654)” on page 4-62.</b></li> </ol>

Error code or message	Error contents	Description/Action	Possible repair actions
203.10	Redrive motor control failure. Media tray 1	The redrive motor does not reach the proper operating speed at the specified time.	<ol style="list-style-type: none"> <li>1. Remove all media present in media path.</li> <li>2. Ensure that upper redrive assembly is properly installed.</li> <li>3. Check all connections on the redrive motor assembly.</li> <li>4. Check all connections on the system card assembly.</li> <li>5. Replace the redrive motor assembly if problem remains. Go to <b>“Redrive assembly removal (T650, T652, T654)” on page 4-62.</b></li> </ol>
203.18	Redrive motor assembly underspeed error.	The redrive motor assembly does not rotate at the specified speed.	<ol style="list-style-type: none"> <li>1. Remove all media present in media path.</li> <li>2. Ensure that upper redrive assembly is properly installed.</li> <li>3. Check all connections on the redrive motor assembly.</li> <li>4. Check all connections on the system card assembly.</li> <li>5. Replace the redrive motor assembly if problem remains. Go to <b>“Redrive assembly removal (T650, T652, T654)” on page 4-62.</b></li> </ol>
203.20	Redrive motor lost encoder failure	The redrive motor is not reporting pulses back to the engine.	<ol style="list-style-type: none"> <li>1. Check all connections on the redrive motor assembly.</li> <li>2. Check all connections on the system card assembly.</li> <li>3. Replace the redrive motor assembly if problem remains. Go to <b>“Redrive assembly removal (T650, T652, T654)” on page 4-62</b></li> </ol>
230.00	Paper jam around internal duplex. Source = Internal duplex	Page may be jammed in internal duplex area.	<ol style="list-style-type: none"> <li>1. Remove all media present in media path.</li> <li>2. Check for obstructions in media path.</li> <li>3. Go to sensor (fuser output) service check. See <b>“Sensor (fuser output) service check” on page 2-126.</b></li> <li>4. Go to sensor (duplex input) service check. See <b>“Sensor (duplex input) service check” on page 2-127.</b></li> </ol>
230.01	Sensor (duplex input) lingering jam Source = Internal duplex	Media reached the sensor (duplex input) but did not clear it in the specified time.	Go to sensor (duplex input) lingering jam service check. See <b>“Sensor (pass through) late jam service check” on page 2-145.</b>

Error code or message	Error contents	Description/Action	Possible repair actions
230.02	Sensor (duplex input) late jam Source = Internal duplex	Media is late reaching the sensor (duplex input) within the specified time.	Go to sensor (duplex input) late jam service check. See <b>“Sensor (duplex input) late jam service check.” on page 2-141.</b>
230.03	Sensor (duplex input) bounce Source = Internal duplex	The sensor (duplex input) rebounded once the trailing edge of the media passed.	Go to sensor (duplex input) service check. See <b>“Sensor (duplex input) service check” on page 2-127.</b>
230.04	Sensor (input) late jam from duplex Source = Internal duplex	Media is late reaching the sensor (input) within the specified time during the second side printing using the internal duplex.	Go to sensor (input) late jam service check. See <b>“Sensor (input) late jam service check.” on page 2-129.</b>
230.05	sensor (duplex input) lingering jam Source = Internal duplex	Media reached the sensor (duplex input) but did not clear it in the specified time.	Go to sensor (duplex input) lingering jam service check. See <b>“Sensor (pass through) late jam service check” on page 2-145.</b>
230.06	Sensor (input) late jam from duplex Source = Internal duplex	Media is late reaching the sensor (input) within the specified time during the second side printing using the internal duplex.	Go to sensor (input) late jam service check. See <b>“Sensor (input) late jam service check.” on page 2-129.</b>
230.07	Sensor (input) late jam from duplex Source = Internal duplex	Media is late reaching the sensor (input) within the specified time during the second side printing using the internal duplex.	Go to sensor (input) late jam service check. See <b>“Sensor (input) late jam service check.” on page 2-129.</b>
230.08	Internal duplex drive motor load error Source = Internal duplex	The internal duplex drive motor assembly has failed or caused high mechanical load during warm up sequence.	<ol style="list-style-type: none"> <li>1. Remove all media present in media path.</li> <li>2. Check all connections on the duplex media entrance drive motor assembly.</li> <li>3. Check all connections on the system card assembly.</li> <li>4. Replace the duplex drive motor assembly if problem remains. Go to <b>“Duplex drive motor assembly removal (T652, T654)” on page 4-19.</b></li> </ol>

Error code or message	Error contents	Description/Action	Possible repair actions
230.10	Internal duplex drive motor control failure. Source = Internal duplex	The internal duplex drive motor does not reach the proper operating speed at the specified time.	<ol style="list-style-type: none"> <li>1. Remove all media present in media path.</li> <li>2. Check all connections on the duplex media entrance drive motor assembly.</li> <li>3. Check all connections on the system card assembly.</li> <li>4. Replace the duplex media entrance drive motor assembly if problem remains. Go to <b>“Duplex drive motor assembly removal (T652, T654)” on page 4-19.</b></li> </ol>
230.13	sensor (duplex input) static jam Source = Internal duplex	Media remains on the sensor (duplex input) during the warm up sequence.	<p>Go to sensor (duplex input) static jam service check.</p> <p>See <b>“Sensor (duplex input) lingering jam service check.” on page 2-142.</b></p>
230.14	Paper jam around internal duplex. Source = Internal duplex	Page may be jammed in internal duplex area.	<ol style="list-style-type: none"> <li>1. Remove all media present in media path.</li> <li>2. Check for obstructions in media path.</li> <li>3. Go to sensor (fuser output) service check. See <b>“Sensor (fuser output) service check” on page 2-126.</b></li> <li>4. Go to sensor (duplex input) service check. See <b>“Sensor (duplex input) service check” on page 2-127.</b></li> </ol>
230.18	Internal duplex drive motor assembly underspeed error. Source = Internal duplex	The internal duplex drive motor does not rotate at the specified speed.	<ol style="list-style-type: none"> <li>1. Remove all media present in media path.</li> <li>2. Check all connections on the duplex media entrance drive motor assembly.</li> <li>3. Check all connections on the system card assembly.</li> <li>4. Replace the duplex media entrance drive motor assembly if problem remains. Go to <b>“Duplex drive motor assembly removal (T652, T654)” on page 4-19.</b></li> </ol>



Error code or message	Error contents	Description/Action	Possible repair actions
230.20	Internal duplex drive motor lost encoder failure Source = Internal duplex	The internal duplex drive motor is not reporting pulses back to the engine.	<ol style="list-style-type: none"> <li>1. Remove all media present in media path.</li> <li>2. Check all connections on the duplex media entrance drive motor assembly.</li> <li>3. Check all connections on the system card assembly.</li> <li>4. Replace the duplex drive motor assembly if problem remains. Go to <b>“Duplex drive motor assembly removal (T652, T654)” on page 4-19.</b></li> </ol>
231.00	Sensor (duplex input) late jam Source = External duplex	Media is late reaching the sensor (duplex input) within the specified time.	Go to sensor (duplex input) late jam service check. See <b>“Sensor (duplex input) late jam service check.” on page 2-141.</b>
232.00	Sensor (duplex input) lingering jam Source = External duplex	Media reached the sensor (duplex input) but did not clear it in the specified time.	Go to sensor (duplex input) lingering jam service check. See <b>“Sensor (pass through) late jam service check” on page 2-145.</b>
233.00	Sensor (duplex double-feed) late jam Source = External duplex	Media is late reaching the sensor (duplex double-feed) within the specified time.	<ol style="list-style-type: none"> <li>1. Remove all media present in media path.</li> <li>2. Check for obstructions in media path.</li> <li>3. Ensure the external duplex assembly is properly installed.</li> <li>4. Ensure the rear door of the external duplex is fully closed.</li> <li>5. Check all connections on the external duplex assembly.</li> <li>6. Replace the external duplex assembly if problem remains.</li> </ol>

Error code or message	Error contents	Description/Action	Possible repair actions
234.00	Sensor (duplex exit) late jam Source = External duplex	Media is late reaching the sensor (duplex exit) within the specified time.	<ol style="list-style-type: none"> <li>1. Remove all media present in media path.</li> <li>2. Check media for proper installation.</li> <li>3. Check for obstructions in media path.</li> <li>4. Ensure the external duplex assembly is properly installed.</li> <li>5. Ensure the rear door of the external duplex is fully closed.</li> <li>6. Check sensor (duplex exit) for proper operation. See <b>“Sensor (duplex exit) service check (external duplex only)” on page 2-128.</b></li> <li>7. Check all connections on the external duplex assembly.</li> <li>8. Replace the external duplex assembly if problem remains.</li> </ol>
235.00	Sensor (duplex double-feed) lingering jam Source = External duplex	Media reached the sensor (duplex double-feed) within the specified time but did not clear it within the specified time.	<ol style="list-style-type: none"> <li>1. Remove all media present in media path.</li> <li>2. Check media for proper installation.</li> <li>3. Check for obstructions in media path.</li> <li>4. Ensure the external duplex assembly is properly installed.</li> <li>5. Replace the external duplex assembly if problem remains.</li> </ol>
236.00	Sensor (duplex exit) lingering jam Source = External duplex	Media reached the sensor (duplex exit) within the specified time but did not clear it within the specified time.	<ol style="list-style-type: none"> <li>1. Remove all media present in media path.</li> <li>2. Check media for proper installation.</li> <li>3. Check for obstructions in media path.</li> <li>4. Ensure the external duplex assembly is properly installed.</li> <li>5. Check sensor (duplex exit) for proper operation. See <b>“Sensor (duplex exit) service check (external duplex only)” on page 2-128.</b></li> <li>6. Replace the external duplex assembly if problem remains.</li> </ol>
237.00	Sensor (input) late jam from duplex Source = External duplex	Media is late reaching the sensor (input) within the specified time during the second side printing using the external duplex.	Go to sensor (input) late jam service check. See <b>“Sensor (input) late jam service check.” on page 2-129.</b>

Error code or message	Error contents	Description/Action	Possible repair actions
237.07	Paper jam around external duplex Source = External duplex.	Page may be jammed in external duplex area.	<ol style="list-style-type: none"> <li>1. Remove all media present in media path.</li> <li>2. Check media for proper installation.</li> <li>3. Check for obstructions in media path.</li> <li>4. Ensure the external duplex assembly is properly installed.</li> <li>5. Ensure the rear door of the external duplex is fully closed.</li> <li>6. Ensure the external duplex tray is fully closed.</li> <li>7. Ensure the media tray 1 is fully closed.</li> <li>8. Check the lower option drive (PTO) assembly for damage.</li> <li>9. Check all connections on the external duplex assembly.</li> <li>10. Replace the external duplex assembly if problem remains.</li> </ol>
238.00	External duplex sensor static jam Source = External duplex	Media remains on a sensor within the external duplex assembly during the warm up sequence.	<ol style="list-style-type: none"> <li>1. Remove all media present in media path.</li> <li>2. Replace the external duplex assembly if problem remains.</li> </ol>
238.01	Sensor (duplex input) static jam Source = External duplex	Media remains on the sensor (duplex input) during the warm up sequence.	Go to sensor (duplex input) static jam service check. See <b>“Sensor (duplex input) lingering jam service check.” on page 2-142.</b>
238.02	Sensor (duplex exit) static jam Source = External duplex	Media remains on the sensor (duplex exit) during the warm up sequence.	<ol style="list-style-type: none"> <li>1. Remove all media present in media path.</li> <li>2. Go to sensor (duplex exit) service check. See <b>“Sensor (duplex exit) service check (external duplex only)” on page 2-128.</b></li> <li>3. Replace the external duplex assembly if problem remains.</li> </ol>
238.03	Sensor (duplex input) static jam Sensor (duplex exit) static jam Source = External duplex	Media remains on the sensor (duplex input) and the sensor (duplex exit) during the warm up sequence.	Go to sensor (duplex input) static jam service check. See <b>“Sensor (duplex input) lingering jam service check.” on page 2-142.</b>

Error code or message	Error contents	Description/Action	Possible repair actions
238.04	Sensor (duplex double-feed) static jam Source = External duplex	Media remains on the sensor (duplex double-feed) during the warm up sequence.	<ol style="list-style-type: none"> <li>1. Remove all media present in media path.</li> <li>2. Replace the external duplex assembly if problem remains.</li> </ol>
238.05	Sensor (duplex input) static jam Sensor (double-feed) static jam Source = External duplex	Media remains on the sensor (duplex input) and the sensor (double-feed) during the warm up sequence.	<ol style="list-style-type: none"> <li>1. Remove all media present in media path.</li> <li>2. Go to sensor (duplex input) static jam service check.</li> </ol> <p>See <b>“Sensor (duplex input) lingering jam service check.” on page 2-142.</b></p>
238.06	Sensor (duplex exit) static jam Sensor (double-feed) static jam Source = External duplex	Media remains on the sensor (duplex exit) and the sensor (double-feed) during the warm up sequence.	<ol style="list-style-type: none"> <li>1. Remove all media present in media path.</li> <li>2. Go to sensor (duplex exit) service check. See <b>“Sensor (duplex exit) service check (external duplex only)” on page 2-128.</b></li> <li>3. Replace the external duplex assembly if problem remains.</li> </ol>
238.07	Sensor (duplex input) static jam Sensor (double-feed) static jam Sensor (duplex exit) Source = External duplex	Media remains on the sensor (duplex input), sensor (double-feed) and the sensor (duplex exit) during the warm up sequence.	<p>Go to sensor (duplex input) static jam service check.</p> <p>See <b>“Sensor (duplex input) lingering jam service check.” on page 2-142.</b></p>
239.00	Mechanical feed error or timing error. Source = External duplex	Mechanical feed error or timing error.	<ol style="list-style-type: none"> <li>1. Remove all media present in media path.</li> <li>2. Check sensor (duplex input) for proper operation. See <b>“Sensor (duplex input) service check” on page 2-127.</b></li> <li>3. Check sensor (duplex exit) for proper operation. See <b>“Sensor (duplex exit) service check (external duplex only)” on page 2-128.</b></li> <li>4. Replace the external duplex assembly if problem remains.</li> </ol>

Error code or message	Error contents	Description/Action	Possible repair actions
239.01	External duplex assembly error Source = External duplex	Mechanical feed error or timing error.	<ol style="list-style-type: none"> <li>1. Remove all media present in media path.</li> <li>2. Check media for proper installation.</li> <li>3. Check for obstructions in media path.</li> <li>4. Ensure the external duplex assembly is properly installed.</li> <li>5. Ensure the rear door of the external duplex is fully closed.</li> <li>6. Check all connections on the external duplex assembly.</li> <li>7. Replace the external duplex assembly if problem remains.</li> </ol>
239.02	External duplex assembly error Source = External duplex	Mechanical feed error or timing error.	<ol style="list-style-type: none"> <li>1. Remove all media present in media path.</li> <li>2. Check media for proper installation.</li> <li>3. Check for obstructions in media path.</li> <li>4. Ensure the external duplex assembly is properly installed.</li> <li>5. Ensure the rear door of the external duplex is fully closed.</li> <li>6. Check all connections on the external duplex assembly.</li> <li>7. Replace the external duplex assembly if problem remains.</li> </ol>
239.03	Device controls response error. Source = External duplex	Mechanical feed error or timing error.	<ol style="list-style-type: none"> <li>1. Remove all media present in media path.</li> <li>2. Check media for proper installation.</li> <li>3. Check for obstructions in media path.</li> <li>4. Ensure the external duplex assembly is properly installed.</li> <li>5. Ensure the rear door of the external duplex is fully closed.</li> <li>6. Check all connections on the external duplex assembly.</li> <li>7. Replace the external duplex assembly if problem remains.</li> </ol>

<b>Error code or message</b>	<b>Error contents</b>	<b>Description/Action</b>	<b>Possible repair actions</b>
239.04	Input device ready response error. Source = External duplex	Mechanical feed error or timing error.	<ol style="list-style-type: none"> <li>1. Remove all media present in media path.</li> <li>2. Check media for proper installation.</li> <li>3. Check for obstructions in media path.</li> <li>4. Ensure the external duplex assembly is properly installed.</li> <li>5. Ensure the rear door of the external duplex is fully closed.</li> <li>6. Check all connections on the external duplex assembly.</li> <li>7. Replace the external duplex assembly if problem remains.</li> </ol>
239.05	Output device response error. Source = External duplex	Mechanical feed error or timing error.	<ol style="list-style-type: none"> <li>1. Remove all media present in media path.</li> <li>2. Check media for proper installation.</li> <li>3. Check for obstructions in media path.</li> <li>4. Ensure the external duplex assembly is properly installed.</li> <li>5. Ensure the rear door of the external duplex is fully closed.</li> <li>6. Check all connections on the external duplex assembly.</li> <li>7. Replace the external duplex assembly if problem remains.</li> </ol>
239.06	Failed the last page of a staple job. Source = External duplex	Mechanical feed error or timing error.	<ol style="list-style-type: none"> <li>1. Remove all media present in media path.</li> <li>2. Check media for proper installation.</li> <li>3. Check for obstructions in media path.</li> <li>4. Ensure the external duplex assembly is properly installed.</li> <li>5. Ensure the rear door of the external duplex is fully closed.</li> <li>6. Check all connections on the external duplex assembly.</li> <li>7. Replace the external duplex assembly if problem remains.</li> </ol>

Error code or message	Error contents	Description/Action	Possible repair actions
239.07	Select output device error. Source = External duplex	Mechanical feed error or timing error.	<ol style="list-style-type: none"> <li>1. Remove all media present in media path.</li> <li>2. Check media for proper installation.</li> <li>3. Check for obstructions in media path.</li> <li>4. Ensure the external duplex assembly is properly installed.</li> <li>5. Ensure the rear door of the external duplex is fully closed.</li> <li>6. Check all connections on the external duplex assembly.</li> <li>7. Replace the external duplex assembly if problem remains.</li> </ol>
239.08	Input source ready error. Source = External duplex	Mechanical feed error or timing error.	<ol style="list-style-type: none"> <li>1. Remove all media present in media path.</li> <li>2. Check media for proper installation.</li> <li>3. Check for obstructions in media path.</li> <li>4. Ensure the external duplex assembly is properly installed.</li> <li>5. Ensure the rear door of the external duplex is fully closed.</li> <li>6. Check all connections on the external duplex assembly.</li> <li>7. Replace the external duplex assembly if problem remains.</li> </ol>
239.11	Sensor (input) late jam from duplex Source = External duplex	Media is late reaching the sensor (input) within the specified time during the second side printing using the external duplex.	Go to sensor (input) late jam service check. See <b>“Sensor (input) late jam service check.”</b> on <b>page 2-129.</b>
241.00	Media tray 1 area jam Source = Tray 1	The media is jammed in the media tray 1 area.	<ol style="list-style-type: none"> <li>1. Remove all media present in media path.</li> <li>2. Check media for proper installation.</li> <li>3. Check for obstructions in media path.</li> </ol>

Error code or message	Error contents	Description/Action	Possible repair actions
241.01	Pick motor control failure. Media tray 1	The pick motor does not reach the proper operating speed at the specified time.	<ol style="list-style-type: none"> <li>1. Remove all media present in media path.</li> <li>2. Ensure media tray is not overfilled.</li> <li>3. Check all connections on the pick arm assembly.</li> <li>4. Check all connections on the system card assembly.</li> <li>5. Replace the pick arm assembly if problem remains. Go to <b>“Operator panel door assembly removal (models X651, X652, X654, and X656)” on page 4-49.</b></li> <li>6. Replace system card assembly if problem remains. Go to <b>“System card assembly removal (T650, T652, T654, T656)” on page 4-76.</b></li> </ol>
241.06	Sensor (input) late jam Source = Tray 1 or MPF	The media is late reaching the sensor (input) within the specified time.	<p>Go to sensor (input) late jam service check.</p> <p>See <b>“Sensor (input) late jam service check.” on page 2-129.</b></p>
241.07	Pick motor load error Source = Media tray 1	The pick motor has failed or caused high mechanical load due to paper jam or bind.	<ol style="list-style-type: none"> <li>1. Remove all media present in media path.</li> <li>2. Ensure media tray is not overfilled.</li> <li>3. Check, clean or replace the pick rolls for wear and excess contamination. Go to <b>“Pick roll assembly removal (T650, T652, T654)” on page 4-57.</b></li> <li>4. Check all connections on the pick arm assembly.</li> <li>5. Check all connections on the system card assembly.</li> <li>6. Replace the pick arm assembly if problem remains. Go to <b>“Operator panel door assembly removal (models X651, X652, X654, and X656)” on page 4-49.</b></li> <li>7. Replace system card assembly if problem remains. Go to <b>“System card assembly removal (T650, T652, T654, T656)” on page 4-76.</b></li> </ol>



Error code or message	Error contents	Description/Action	Possible repair actions
241.08	Pick motor load error Source = Media tray 1	The pick motor has failed or caused high mechanical load due to paper jam or bind.	<ol style="list-style-type: none"> <li>1. Remove all media present in media path.</li> <li>2. Ensure media tray is not overfilled.</li> <li>3. Check, clean or replace the pick rolls for wear and excess contamination. Go to <b>“Pick roll assembly removal (T650, T652, T654)” on page 4-57.</b></li> <li>4. Check all connections on the pick arm assembly.</li> <li>5. Check all connections on the system card assembly.</li> <li>6. Replace the pick arm assembly if problem remains. Go to <b>“Operator panel door assembly removal (models X651, X652, X654, and X656)” on page 4-49.</b></li> <li>7. Replace system card assembly if problem remains. Go to <b>“System card assembly removal (T650, T652, T654, T656)” on page 4-76.</b></li> </ol>
241.10	Sensor (input) late jam Source = Tray 1	The media is late reaching the sensor (input) within the specified time.	Go to sensor (input) late jam service check. See <b>“Sensor (input) late jam service check.” on page 2-129.</b>
241.11	Sensor (input) late jam Source = Tray 1	The media is late reaching the sensor (input) within the specified time.	Go to sensor (input) late jam service check. See <b>“Sensor (input) late jam service check.” on page 2-129.</b>
241.12	Sensor (input) late jam Source = Tray 1 or envelope feeder	The media is late reaching the sensor (input) within the specified time.	Go to sensor (input) late jam service check. See <b>“Sensor (input) late jam service check.” on page 2-129.</b>
241.14	Sensor (input) late jam Source = Tray 1 or envelope feeder	The media is late reaching the sensor (input) within the specified time.	Go to sensor (input) late jam service check. See <b>“Sensor (input) late jam service check.” on page 2-129.</b>
241.15	Sensor (input) late jam Source = Tray 1 or envelope feeder	The media is late reaching the sensor (input) within the specified time.	Go to sensor (input) late jam service check. See <b>“Sensor (input) late jam service check.” on page 2-129.</b>

Error code or message	Error contents	Description/Action	Possible repair actions
241.16	Sensor (input) late jam Source = Tray 1	The media is late reaching the sensor (input) within the specified time.	Go to sensor (input) late jam service check. See <b>“Sensor (input) late jam service check.”</b> on page 2-129.
241.18	Sensor (input) late jam Source = Tray 1	The media is late reaching the sensor (input) within the specified time.	Go to sensor (input) late jam service check. See <b>“Sensor (input) late jam service check.”</b> on page 2-129.
241.19	Pick motor control failure. Source = Tray 1	The pick motor does not reach the proper operating speed at the specified time.	<ol style="list-style-type: none"> <li>1. Remove all media present in media path.</li> <li>2. Ensure media tray is not overfilled.</li> <li>3. Check all connections on the pick arm assembly.</li> <li>4. Check all connections on the system card assembly.</li> <li>5. Replace the pick arm assembly if problem remains. Go to <b>“Operator panel door assembly removal (models X651, X652, X654, and X656)”</b> on page 4-49.</li> <li>6. Replace system card assembly if problem remains. Go to <b>“System card assembly removal (T650, T652, T654, T656)”</b> on page 4-76.</li> </ol>
241.20	Tray 1 pick motor lost encoder failure Source = Tray 1	The pick motor is not reporting pulses back to the engine.	<ol style="list-style-type: none"> <li>1. Check all connections on the pick arm assembly.</li> <li>2. Check all connections on the system card assembly.</li> <li>3. Replace the pick arm assembly if problem remains. Go to <b>“Operator panel door assembly removal (models X651, X652, X654, and X656)”</b> on page 4-49.</li> </ol>
242.00	Media tray 2 area jam Source = Tray 2	The media is jammed in the media tray 2 area.	<ol style="list-style-type: none"> <li>1. Remove all media present in media path.</li> <li>2. Check media for proper installation.</li> <li>3. Check for obstructions in media path.</li> </ol>
242.02	Sensor (pass through) late jam Source = Tray 2	The media is late reaching the sensor (pass through) within the specified time.	Go to sensor (pass through) late jam service check. See <b>“Sensor (pass through) late jam service check”</b> on page 2-145.

Error code or message	Error contents	Description/Action	Possible repair actions
242.03	Sensor (pass through) late jam Source = Tray 2	The media is late reaching the sensor (pass through) within the specified time.	Go to sensor (pass through) late jam service check. See <b>“Sensor (pass through) late jam service check” on page 2-145.</b>
242.04	Sensor (pass through) late jam Source = Tray 2	The media is late reaching the sensor (pass through) within the specified time.	Go to sensor (pass through) late jam service check. See <b>“Sensor (pass through) late jam service check” on page 2-145.</b>
242.05	Sensor (pass through) late jam Source = Tray 2	The media is late reaching the sensor (pass through) within the specified time.	Go to sensor (pass through) late jam service check. See <b>“Sensor (pass through) late jam service check” on page 2-145.</b>
242.06	Sensor (pass through) late jam Source = Tray 2	The media is late reaching the sensor (pass through) within the specified time.	Go to sensor (pass through) late jam service check. See <b>“Sensor (pass through) late jam service check” on page 2-145.</b>
242.08	Sensor (pass through) lingering jam Source = Tray 2	Media reached the sensor (pass through) within the specified time but did not clear it within the specified time.	Go to sensor (pass through) lingering jam service check. See <b>“Sensor (pass through) lingering jam service check.” on page 2-146.</b>
242.09	Sensor (input) late jam Source = Tray 2	The media is late reaching the sensor (input) within the specified time.	Go to sensor (input) late jam service check. See <b>“Sensor (input) late jam service check.” on page 2-129.</b>
242.10	sensor (pass through) late jam Source = Tray 2	The media is late reaching the sensor (pass through) within the specified time.	Go to sensor (pass through) late jam service check. See <b>“Sensor (pass through) late jam service check” on page 2-145.</b>
242.13	Sensor (pass through) static jam Source = Tray 2	Media remains on the sensor (input) during the warm up sequence.	Go to sensor (pass through) static jam service check. See <b>“Sensor (pass through) static jam service check” on page 2-147.</b>
242.16	sensor (pass through) late jam Source = Tray 2	The media is late reaching the sensor (pass through) within the specified time.	Go to sensor (pass through) late jam service check. See <b>“Sensor (pass through) late jam service check” on page 2-145.</b>
242.17	Media tray pulled jam Source = Tray 2	A media tray above the source tray was pulled during the printing process.	1. Remove all media present in media path. 2. Close all media trays.

Error code or message	Error contents	Description/Action	Possible repair actions
242.18	Pick retry timeout Source = Tray 2	The engine timed out waiting for the tray 2 to report ready before the first pick attempt.	Turn the machine off/on.
242.19	Pick retry timeout Source = Tray 2	The engine timed out waiting for the tray 2 to report ready before a pick retry attempt.	Turn the machine off/on.
242.52	Tray 2 pick motor overrun failure Source = Tray 2	The Pick motor encoder continues to detect pulses after the motor was turned off.	<ol style="list-style-type: none"> <li>1. Check all connections on the pick arm assembly.</li> <li>2. Check all connections on the system card assembly.</li> <li>3. Replace the pick arm assembly if problem remains. Go to <b>“Operator panel door assembly removal (models X651, X652, X654, and X656)” on page 4-49.</b></li> </ol>
242.33	Tray 2 not ready Source = Tray 2	Tray was not properly pushed into the machine.	<ol style="list-style-type: none"> <li>1. Check the size sensing fingers on the media tray for damage</li> <li>2. Replace the media tray assembly if problem remains.</li> <li>3. Check the switch (media size) for proper connection.</li> <li>4. Replace the switch (media size) if problem remains. Go to <b>“Switch (media size) assembly removal (T650, T652, T654)” on page 4-74.</b></li> </ol>
242.34	Empty tray pick attempted Source = Tray 2	The pick arm attempted to pick with no media in the tray.	<ol style="list-style-type: none"> <li>1. Check the media out actuator for damage.</li> <li>2. Replace the media out actuator if problem remains. Go to <b>“Tray roller catch assembly removal (T650, T652, T654)” on page 4-81.</b></li> </ol>
242.35	Pick page received while POR not yet done. Source = Tray 2	Media remains on the sensor (input) during the warm up sequence.	Go to sensor (pass through) static jam service check. See <b>“Sensor (pass through) static jam service check” on page 2-147.</b>
242.36	Sensor (pass through) static jam Source = Tray 2	Media remains on the sensor (input) during the warm up sequence.	Go to sensor (pass through) static jam service check. See <b>“Sensor (pass through) static jam service check” on page 2-147.</b>
242.37	Sensor (pass through) late jam Source = Tray 2	The media is late reaching the sensor (pass through) within the specified time.	Go to sensor (pass through) late jam service check. See <b>“Sensor (pass through) late jam service check” on page 2-145.</b>

Error code or message	Error contents	Description/Action	Possible repair actions
242.39	Media tray pulled jam	A media tray above the source tray was pulled during the printing process.	<ol style="list-style-type: none"> <li>1. Remove all media present in media path.</li> <li>2. Close all media trays.</li> </ol>
242.40	Sensor (pass through) lingering jam Source = Tray 2	Media reached the sensor (pass through) within the specified time but did not clear it within the specified time.	<p>Go to sensor (pass through) lingering jam service check.</p> <p>See <b>“Sensor (pass through) lingering jam service check.” on page 2-146.</b></p>
242.49	HCIT tray lift motor stalled failure Source = Tray 2	The HCIT tray lift motor has stalled or has become obstructed.	<ol style="list-style-type: none"> <li>1. Ensure the HCIT media tray assembly is properly inserted into the machine.</li> <li>2. Check the HCIT tray lift motor assembly for binding or damage.</li> <li>3. Replace the HCIT tray lift drive motor assembly if problem remains.</li> </ol> <p>Go to <b>“High capacity input tray (HCIT) tray lift drive motor assembly removal” on page 4-125.</b></p>
242.50	HCIT tray lift motor underspeed failure Source = Tray 2	The HCIT tray lift motor does not rotate at the specified speed.	<ol style="list-style-type: none"> <li>1. Ensure the HCIT media tray assembly is properly inserted into the machine.</li> <li>2. Check the HCIT tray lift drive motor assembly for binding or damage.</li> <li>3. Replace the HCIT tray lift motor assembly if problem remains.</li> </ol> <p>Go to <b>“High capacity input tray (HCIT) tray lift drive motor assembly removal” on page 4-125.</b></p>
242.52	HCIT tray lift motor overrun failure Source = Tray 2	The HCIT tray lift motor continues to detect pulses after the motor has turned off.	<ol style="list-style-type: none"> <li>1. Ensure the HCIT media tray assembly is properly inserted into the machine.</li> <li>2. Check the HCIT tray lift motor assembly for binding or damage.</li> <li>3. Replace the HCIT tray lift drive motor assembly if problem remains.</li> </ol> <p>Go to <b>“High capacity input tray (HCIT) tray lift drive motor assembly removal” on page 4-125.</b></p>

Error code or message	Error contents	Description/Action	Possible repair actions
242.65	Pick motor load error Source = Media tray 2	The pick motor has failed or caused high mechanical load due to paper jam or bind.	<ol style="list-style-type: none"> <li>1. Remove all media present in media path.</li> <li>2. Ensure media tray is not overfilled.</li> <li>3. Check, clean or replace the pick rolls for wear and excess contamination. Go to <b>“Pick roll assembly removal (T650, T652, T654)” on page 4-57.</b></li> <li>4. Check all connections on the pick arm assembly.</li> <li>5. Check all connections on the system card assembly.</li> <li>6. Replace the pick arm assembly if problem remains. Go to <b>“Operator panel door assembly removal (models X651, X652, X654, and X656)” on page 4-49.</b></li> <li>7. Replace system card assembly if problem remains. Go to <b>“System card assembly removal (T650, T652, T654, T656)” on page 4-76.</b></li> </ol>
242.66	Pick motor underspeed failure Source = Media tray 2	The pick motor does not rotate at the specified speed.	<ol style="list-style-type: none"> <li>1. Remove all media present in media path.</li> <li>2. Ensure media tray is not overfilled.</li> <li>3. Check all connections on the pick arm assembly.</li> <li>4. Check all connections on the system card assembly.</li> <li>5. Replace the pick arm assembly if problem remains. Go to <b>“Operator panel door assembly removal (models X651, X652, X654, and X656)” on page 4-49.</b></li> <li>6. Replace system card assembly if problem remains. Go to <b>“System card assembly removal (T650, T652, T654, T656)” on page 4-76.</b></li> </ol>

Error code or message	Error contents	Description/Action	Possible repair actions
242.67	Pick motor overspeed failure Source = Media tray 2	The pick motor does not rotate at the specified speed.	<ol style="list-style-type: none"> <li>1. Remove all media present in media path.</li> <li>2. Ensure media tray is not overfilled.</li> <li>3. Check all connections on the pick arm assembly.</li> <li>4. Check all connections on the system card assembly.</li> <li>5. Replace the pick arm assembly if problem remains. Go to <b>“Operator panel door assembly removal (models X651, X652, X654, and X656)” on page 4-49.</b></li> <li>6. Replace system card assembly if problem remains. Go to <b>“System card assembly removal (T650, T652, T654, T656)” on page 4-76.</b></li> </ol>
242.68	Pick motor stop error Source = Media tray 2	Pick motor stop error detected by options tray x	<ol style="list-style-type: none"> <li>1. Remove all media present in media path.</li> <li>2. Ensure media tray is not overfilled.</li> <li>3. Check all connections on the pick arm assembly.</li> <li>4. Check all connections on the system card assembly.</li> <li>5. Replace the pick arm assembly if problem remains. Go to <b>“Operator panel door assembly removal (models X651, X652, X654, and X656)” on page 4-49.</b></li> <li>6. Replace system card assembly if problem remains. Go to <b>“System card assembly removal (T650, T652, T654, T656)” on page 4-76.</b></li> </ol>

Error code or message	Error contents	Description/Action	Possible repair actions
242.69	Pick motor control failure. Source = Media tray 2	The pick motor does not reach the proper operating speed at the specified time.	<ol style="list-style-type: none"> <li>1. Remove all media present in media path.</li> <li>2. Ensure media tray is not overfilled.</li> <li>3. Check all connections on the pick arm assembly.</li> <li>4. Check all connections on the system card assembly.</li> <li>5. Replace the pick arm assembly if problem remains. Go to <b>“Operator panel door assembly removal (models X651, X652, X654, and X656)” on page 4-49.</b></li> <li>6. Replace system card assembly if problem remains. Go to <b>“System card assembly removal (T650, T652, T654, T656)” on page 4-76.</b></li> </ol>
243.00	Media tray 3 area jam	The media is jammed in the media tray 3 area.	<ol style="list-style-type: none"> <li>1. Remove all media present in media path.</li> <li>2. Check media for proper installation.</li> <li>3. Check for obstructions in media path.</li> </ol>
243.02	Sensor (pass through) late jam Source = Tray 3	The media is late reaching the sensor (pass through) within the specified time.	Go to sensor (pass through) late jam service check. See <b>“Sensor (pass through) late jam service check” on page 2-145.</b>
243.03	Sensor (pass through) late jam Source = Tray 3	The media is late reaching the sensor (pass through) within the specified time.	Go to sensor (pass through) late jam service check. See <b>“Sensor (pass through) late jam service check” on page 2-145.</b>
243.04	Sensor (pass through) late jam Source = Tray 3	The media is late reaching the sensor (pass through) within the specified time.	Go to sensor (pass through) late jam service check. See <b>“Sensor (pass through) late jam service check” on page 2-145.</b>
243.05	Sensor (pass through) late jam Source = Tray 3	The media is late reaching the sensor (pass through) within the specified time.	Go to sensor (pass through) late jam service check. See <b>“Sensor (pass through) late jam service check” on page 2-145.</b>
243.06	Sensor (pass through) late jam Source = Tray 3	The media is late reaching the sensor (pass through) within the specified time.	Go to sensor (pass through) late jam service check. See <b>“Sensor (pass through) late jam service check” on page 2-145.</b>



Error code or message	Error contents	Description/Action	Possible repair actions
243.08	Sensor (pass through) lingering jam Source = Tray 3	Media reached the sensor (pass through) within the specified time but did not clear it within the specified time.	Go to sensor (pass through) lingering jam service check. See <b>“Sensor (pass through) lingering jam service check.”</b> on page 2-146.
243.10	Sensor (pass through) late jam Source = Tray 3	The media is late reaching the sensor (pass through) within the specified time.	Go to sensor (pass through) late jam service check. See <b>“Sensor (pass through) late jam service check”</b> on page 2-145.
243.13	Sensor (pass through) static jam Source = Tray 3	Media remains on the sensor (input) during the warm up sequence.	Go to sensor (pass through) static jam service check. See <b>“Sensor (pass through) static jam service check”</b> on page 2-147.
243.16	Sensor (pass through) late jam Source = Tray 3	The media is late reaching the sensor (pass through) within the specified time.	Go to sensor (pass through) late jam service check. See <b>“Sensor (pass through) late jam service check”</b> on page 2-145.
243.17	Media tray pulled jam Source = Tray 3	A media tray above the source tray was pulled during the printing process.	<ol style="list-style-type: none"> <li>1. Remove all media present in media path.</li> <li>2. Close all media trays.</li> </ol>
243.18	Pick retry timeout Source = Tray 3	The engine timed out waiting for the tray 3 to report ready before the first pick attempt.	Turn the machine off/on.
243.19	Pick retry timeout Source = Tray 3	The engine timed out waiting for the tray 3 to report ready before a pick retry attempt.	Turn the machine off/on.
243.33	Tray 3 not ready Source = Tray 3	Tray was not properly pushed into the machine.	<ol style="list-style-type: none"> <li>1. Check the size sensing fingers on the media tray for damage</li> <li>2. Replace the media tray assembly if problem remains.</li> <li>3. Check the switch (media size) for proper connection.</li> <li>4. Replace the switch (media size) if problem remains. Go to <b>“Switch (media size) assembly removal (T650, T652, T654)”</b> on page 4-74.</li> </ol>
243.34	Empty tray pick attempted Source = Tray 3	The pick arm attempted to pick with no media in the tray.	<ol style="list-style-type: none"> <li>1. Check the media out actuator for damage.</li> <li>2. Replace the media out actuator if problem remains. Go to <b>“Tray roller catch assembly removal (T650, T652, T654)”</b> on page 4-81.</li> </ol>

Error code or message	Error contents	Description/Action	Possible repair actions
243.35	Pick page received while POR not yet done. Source = Tray 3	Media remains on the sensor (input) during the warm up sequence.	Go to sensor (pass through) static jam service check. See <b>“Sensor (pass through) static jam service check” on page 2-147.</b>
243.36	Sensor (pass through) static jam Source = Tray 3	Media remains on the sensor (input) during the warm up sequence.	Go to sensor (pass through) static jam service check. See <b>“Sensor (pass through) static jam service check” on page 2-147.</b>
243.37	Sensor (pass through) late jam Source = Tray 3	The media is late reaching the sensor (pass through) within the specified time.	Go to sensor (pass through) late jam service check. See <b>“Sensor (pass through) late jam service check” on page 2-145.</b>
243.39	Media tray pulled jam Source = Tray 3	A media tray above the source tray was pulled during the printing process.	<ol style="list-style-type: none"> <li>1. Remove all media present in media path.</li> <li>2. Close all media trays.</li> </ol>
243.40	Sensor (pass through) lingering jam Source = Tray 3	Media reached the sensor (pass through) within the specified time but did not clear it within the specified time.	Go to sensor (pass through) lingering jam service check. See <b>“Sensor (pass through) lingering jam service check.” on page 2-146.</b>
243.49	HCIT tray lift motor stalled failure Source = Tray 3	The HCIT tray lift motor has stalled or has become obstructed.	<ol style="list-style-type: none"> <li>1. Ensure the HCIT media tray assembly is properly inserted into the machine.</li> <li>2. Check the HCIT tray lift motor assembly for binding or damage.</li> <li>3. Replace the HCIT tray lift drive motor assembly if problem remains.</li> </ol> <p>Go to <b>“High capacity input tray (HCIT) tray lift drive motor assembly removal” on page 4-125.</b></p>
243.50	HCIT tray lift motor underspeed failure Source = Tray 3	The HCIT tray lift motor does not rotate at the specified speed.	<ol style="list-style-type: none"> <li>1. Ensure the HCIT media tray assembly is properly inserted into the machine.</li> <li>2. Check the HCIT tray lift motor assembly for binding or damage.</li> <li>3. Replace the HCIT tray lift drive motor assembly if problem remains.</li> </ol> <p>Go to <b>“High capacity input tray (HCIT) tray lift drive motor assembly removal” on page 4-125.</b></p>

Error code or message	Error contents	Description/Action	Possible repair actions
243.52	HCIT tray lift motor overrun failure Source = Tray 3	The HCIT tray lift motor continues to detect pulses after the motor has turned off.	<ol style="list-style-type: none"> <li>1. Ensure the HCIT media tray assembly is properly inserted into the machine.</li> <li>2. Check the HCIT tray lift motor assembly for binding or damage.</li> <li>3. Replace the HCIT tray lift drive motor assembly if problem remains.</li> </ol> <p>Go to <b>“High capacity input tray (HCIT) tray lift drive motor assembly removal” on page 4-125.</b></p>
243.65	Pick motor load error Source = Media tray 3	The pick motor has failed or caused high mechanical load due to paper jam or bind.	<ol style="list-style-type: none"> <li>1. Remove all media present in media path.</li> <li>2. Ensure media tray is not overfilled.</li> <li>3. Check, clean or replace the pick rolls for wear and excess contamination. Go to <b>“Pick roll assembly removal (T650, T652, T654)” on page 4-57.</b></li> <li>4. Check all connections on the pick arm assembly.</li> <li>5. Check all connections on the system card assembly.</li> <li>6. Replace the pick arm assembly if problem remains. Go to <b>“Operator panel door assembly removal (models X651, X652, X654, and X656)” on page 4-49.</b></li> <li>7. Replace system card assembly if problem remains. Go to <b>“System card assembly removal (T650, T652, T654, T656)” on page 4-76.</b></li> </ol>

Error code or message	Error contents	Description/Action	Possible repair actions
243.66	Pick motor underspeed failure Source = Media tray 3	The pick motor does not rotate at the specified speed.	<ol style="list-style-type: none"> <li>1. Remove all media present in media path.</li> <li>2. Ensure media tray is not overfilled.</li> <li>3. Check all connections on the pick arm assembly.</li> <li>4. Check all connections on the system card assembly.</li> <li>5. Replace the pick arm assembly if problem remains. Go to <b>“Operator panel door assembly removal (models X651, X652, X654, and X656)” on page 4-49.</b></li> <li>6. Replace system card assembly if problem remains. Go to <b>“System card assembly removal (T650, T652, T654, T656)” on page 4-76.</b></li> </ol>
243.67	Pick motor overspeed failure Source = Media tray 3	The pick motor does not rotate at the specified speed.	<ol style="list-style-type: none"> <li>1. Remove all media present in media path.</li> <li>2. Ensure media tray is not overfilled.</li> <li>3. Check all connections on the pick arm assembly.</li> <li>4. Check all connections on the system card assembly.</li> <li>5. Replace the pick arm assembly if problem remains. Go to <b>“Operator panel door assembly removal (models X651, X652, X654, and X656)” on page 4-49.</b></li> <li>6. Replace system card assembly if problem remains. Go to <b>“System card assembly removal (T650, T652, T654, T656)” on page 4-76.</b></li> </ol>

Error code or message	Error contents	Description/Action	Possible repair actions
243.68	Pick motor stop error Source = Media tray 3	Pick motor stop error detected by options tray x	<ol style="list-style-type: none"> <li>1. Remove all media present in media path.</li> <li>2. Ensure media tray is not overfilled.</li> <li>3. Check all connections on the pick arm assembly.</li> <li>4. Check all connections on the system card assembly.</li> <li>5. Replace the pick arm assembly if problem remains. Go to <b>“Operator panel door assembly removal (models X651, X652, X654, and X656)” on page 4-49.</b></li> <li>6. Replace system card assembly if problem remains. Go to <b>“System card assembly removal (T650, T652, T654, T656)” on page 4-76.</b></li> </ol>
243.69	Pick motor control failure. Source = Media tray 3	The pick motor does not reach the proper operating speed at the specified time.	<ol style="list-style-type: none"> <li>1. Remove all media present in media path.</li> <li>2. Ensure media tray is not overfilled.</li> <li>3. Check all connections on the pick arm assembly.</li> <li>4. Check all connections on the system card assembly.</li> <li>5. Replace the pick arm assembly if problem remains. Go to <b>“Operator panel door assembly removal (models X651, X652, X654, and X656)” on page 4-49.</b></li> <li>6. Replace system card assembly if problem remains. Go to <b>“System card assembly removal (T650, T652, T654, T656)” on page 4-76.</b></li> </ol>
244.00	Media tray 4 area jam	The media is jammed in the media tray 4 area.	<ol style="list-style-type: none"> <li>1. Remove all media present in media path.</li> <li>2. Check media for proper installation.</li> <li>3. Check for obstructions in media path.</li> </ol>
244.02	Sensor (pass through) late jam Source = Tray 4	The media is late reaching the sensor (pass through) within the specified time.	Go to sensor (pass through) late jam service check. See <b>“Sensor (pass through) late jam service check” on page 2-145.</b>
244.03	Sensor (pass through) late jam Source = Tray 4	The media is late reaching the sensor (pass through) within the specified time.	Go to sensor (pass through) late jam service check. See <b>“Sensor (pass through) late jam service check” on page 2-145.</b>

Error code or message	Error contents	Description/Action	Possible repair actions
244.04	Sensor (pass through) late jam Source = Tray 4	The media is late reaching the sensor (pass through) within the specified time.	Go to sensor (pass through) late jam service check. See <b>“Sensor (pass through) late jam service check” on page 2-145.</b>
244.05	Sensor (pass through) late jam Source = Tray 4	The media is late reaching the sensor (pass through) within the specified time.	Go to sensor (pass through) late jam service check. See <b>“Sensor (pass through) late jam service check” on page 2-145.</b>
244.06	Sensor (pass through) late jam Source = Tray 4	The media is late reaching the sensor (pass through) within the specified time.	Go to sensor (pass through) late jam service check. See <b>“Sensor (pass through) late jam service check” on page 2-145.</b>
244.08	Sensor (pass through) lingering jam Source = Tray 4	Media reached the sensor (pass through) within the specified time but did not clear it within the specified time.	Go to sensor (pass through) lingering jam service check. See <b>“Sensor (pass through) lingering jam service check.” on page 2-146.</b>
244.10	Sensor (pass through) late jam Source = Tray 4	The media is late reaching the sensor (pass through) within the specified time.	Go to sensor (pass through) late jam service check. See <b>“Sensor (pass through) late jam service check” on page 2-145.</b>
244.13	Sensor (pass through) static jam Source = Tray 4	Media remains on the sensor (input) during the warm up sequence.	Go to sensor (pass through) static jam service check. See <b>“Sensor (pass through) static jam service check” on page 2-147.</b>
244.16	Sensor (pass through) late jam Source = Tray 4	The media is late reaching the sensor (pass through) within the specified time.	Go to sensor (pass through) late jam service check. See <b>“Sensor (pass through) late jam service check” on page 2-145.</b>
244.17	Media tray pulled jam	A media tray above the source tray was pulled during the printing process.	1. Remove all media present in media path. 2. Close all media trays.
244.18	Pick retry timeout Source = Tray 4	The engine timed out waiting for the tray 4 to report ready before the first pick attempt.	Turn the machine off/on.
244.19	Pick retry timeout Source = Tray 4	The engine timed out waiting for the tray 4 to report ready before a pick retry attempt.	Turn the machine off/on.

Error code or message	Error contents	Description/Action	Possible repair actions
244.33	Tray 4 not ready Source = Tray 4	Tray was not properly pushed into the machine.	<ol style="list-style-type: none"> <li>1. Check the size sensing fingers on the media tray for damage</li> <li>2. Replace the media tray assembly if problem remains.</li> <li>3. Check the switch (media size) for proper connection.</li> <li>4. Replace the switch (media size) if problem remains. Go to <b>“Switch (media size) assembly removal (T650, T652, T654)” on page 4-74.</b></li> </ol>
244.34	Empty tray pick attempted Source = Tray 4	The pick arm attempted to pick with no media in the tray.	<ol style="list-style-type: none"> <li>1. Check the media out actuator for damage.</li> <li>2. Replace the media out actuator if problem remains. Go to <b>“Tray roller catch assembly removal (T650, T652, T654)” on page 4-81.</b></li> </ol>
244.35	Pick page received while POR not yet done. Source = Tray 4	Media remains on the sensor (input) during the warm up sequence.	Go to sensor (pass through) static jam service check. See <b>“Sensor (pass through) static jam service check” on page 2-147.</b>
244.36	Sensor (pass through) static jam Source = Tray 4	Media remains on the sensor (input) during the warm up sequence.	Go to sensor (pass through) static jam service check. See <b>“Sensor (pass through) static jam service check” on page 2-147.</b>
244.37	Sensor (pass through) late jam Source = Tray 4	The media is late reaching the sensor (pass through) within the specified time.	Go to sensor (pass through) late jam service check. See <b>“Sensor (pass through) late jam service check” on page 2-145.</b>
244.39	Media tray pulled jam Source = Tray 4	A media tray above the source tray was pulled during the printing process.	<ol style="list-style-type: none"> <li>1. Remove all media present in media path.</li> <li>2. Close all media trays.</li> </ol>
244.40	Sensor (pass through) lingering jam Source = Tray 4	Media reached the sensor (pass through) within the specified time but did not clear it within the specified time.	Go to sensor (pass through) lingering jam service check. See <b>“Sensor (pass through) lingering jam service check.” on page 2-146.</b>

Error code or message	Error contents	Description/Action	Possible repair actions
244.49	HCIT tray lift motor stalled failure Source = Tray 4	The HCIT tray lift motor has stalled or has become obstructed.	<ol style="list-style-type: none"> <li>1. Ensure the HCIT media tray assembly is properly inserted into the machine.</li> <li>2. Check the HCIT tray lift motor assembly for binding or damage.</li> <li>3. Replace the HCIT tray lift drive motor assembly if problem remains.</li> </ol> <p>Go to <b>“High capacity input tray (HCIT) tray lift drive motor assembly removal” on page 4-125.</b></p>
244.50	HCIT tray lift motor underspeed failure Source = Tray 4	The HCIT tray lift motor does not rotate at the specified speed.	<ol style="list-style-type: none"> <li>1. Ensure the HCIT media tray assembly is properly inserted into the machine.</li> <li>2. Check the HCIT tray lift motor assembly for binding or damage.</li> <li>3. Replace the HCIT tray lift drive motor assembly if problem remains.</li> </ol> <p>Go to <b>“High capacity input tray (HCIT) tray lift drive motor assembly removal” on page 4-125.</b></p>
244.52	HCIT tray lift motor overrun failure Source = Tray 4	The HCIT tray lift motor continues to detect pulses after the motor has turned off.	<ol style="list-style-type: none"> <li>1. Ensure the HCIT media tray assembly is properly inserted into the machine.</li> <li>2. Check the HCIT tray lift motor assembly for binding or damage.</li> <li>3. Replace the HCIT tray lift drive motor assembly if problem remains.</li> </ol> <p>Go to <b>“High capacity input tray (HCIT) tray lift drive motor assembly removal” on page 4-125.</b></p>



Error code or message	Error contents	Description/Action	Possible repair actions
244.65	Pick motor load error Source = Media tray 4	The pick motor has failed or caused high mechanical load due to paper jam or bind.	<ol style="list-style-type: none"> <li>1. Remove all media present in media path.</li> <li>2. Ensure media tray is not overfilled.</li> <li>3. Check, clean or replace the pick rolls for wear and excess contamination. Go to <b>“Pick roll assembly removal (T650, T652, T654)” on page 4-57.</b></li> <li>4. Check all connections on the pick arm assembly.</li> <li>5. Check all connections on the system card assembly.</li> <li>6. Replace the pick arm assembly if problem remains. Go to <b>“Operator panel door assembly removal (models X651, X652, X654, and X656)” on page 4-49.</b></li> <li>7. Replace system card assembly if problem remains. Go to <b>“System card assembly removal (T650, T652, T654, T656)” on page 4-76.</b></li> </ol>
244.66	Pick motor underspeed failure Source = Media tray 4	The pick motor does not rotate at the specified speed.	<ol style="list-style-type: none"> <li>1. Remove all media present in media path.</li> <li>2. Ensure media tray is not overfilled.</li> <li>3. Check all connections on the pick arm assembly.</li> <li>4. Check all connections on the system card assembly.</li> <li>5. Replace the pick arm assembly if problem remains. Go to <b>“Operator panel door assembly removal (models X651, X652, X654, and X656)” on page 4-49.</b></li> <li>6. Replace system card assembly if problem remains. Go to <b>“System card assembly removal (T650, T652, T654, T656)” on page 4-76.</b></li> </ol>

Error code or message	Error contents	Description/Action	Possible repair actions
244.67	Pick motor overspeed failure Source = Media tray 4	The pick motor does not rotate at the specified speed.	<ol style="list-style-type: none"> <li>1. Remove all media present in media path.</li> <li>2. Ensure media tray is not overfilled.</li> <li>3. Check all connections on the pick arm assembly.</li> <li>4. Check all connections on the system card assembly.</li> <li>5. Replace the pick arm assembly if problem remains. Go to <b>“Operator panel door assembly removal (models X651, X652, X654, and X656)” on page 4-49.</b></li> <li>6. Replace system card assembly if problem remains. Go to <b>“System card assembly removal (T650, T652, T654, T656)” on page 4-76.</b></li> </ol>
244.68	Pick motor stop error Source = Media tray 4	Pick motor stop error detected by options tray x	<ol style="list-style-type: none"> <li>1. Remove all media present in media path.</li> <li>2. Ensure media tray is not overfilled.</li> <li>3. Check all connections on the pick arm assembly.</li> <li>4. Check all connections on the system card assembly.</li> <li>5. Replace the pick arm assembly if problem remains. Go to <b>“Operator panel door assembly removal (models X651, X652, X654, and X656)” on page 4-49.</b></li> <li>6. Replace system card assembly if problem remains. Go to <b>“System card assembly removal (T650, T652, T654, T656)” on page 4-76.</b></li> </ol>

Error code or message	Error contents	Description/Action	Possible repair actions
244.69	Pick motor control failure. Source = Media tray 4	The pick motor does not reach the proper operating speed at the specified time.	<ol style="list-style-type: none"> <li>1. Remove all media present in media path.</li> <li>2. Ensure media tray is not overfilled.</li> <li>3. Check all connections on the pick arm assembly.</li> <li>4. Check all connections on the system card assembly.</li> <li>5. Replace the pick arm assembly if problem remains. Go to <b>“Operator panel door assembly removal (models X651, X652, X654, and X656)” on page 4-49.</b></li> <li>6. Replace system card assembly if problem remains. Go to <b>“System card assembly removal (T650, T652, T654, T656)” on page 4-76.</b></li> </ol>
245.00	Media tray 5 area jam	The media is jammed in the media tray 5 area.	<ol style="list-style-type: none"> <li>1. Remove all media present in media path.</li> <li>2. Check media for proper installation.</li> <li>3. Check for obstructions in media path.</li> </ol>
245.02	Sensor (pass through) late jam Source = Tray 5	The media is late reaching the sensor (pass through) within the specified time.	Go to sensor (pass through) late jam service check. See <b>“Sensor (pass through) late jam service check” on page 2-145.</b>
245.03	Sensor (pass through) late jam Source = Tray 5	The media is late reaching the sensor (pass through) within the specified time.	Go to sensor (pass through) late jam service check. See <b>“Sensor (pass through) late jam service check” on page 2-145.</b>
245.04	Sensor (pass through) late jam Source = Tray 5	The media is late reaching the sensor (pass through) within the specified time.	Go to sensor (pass through) late jam service check. See <b>“Sensor (pass through) late jam service check” on page 2-145.</b>
245.05	Sensor (pass through) late jam Source = Tray 5	The media is late reaching the sensor (pass through) within the specified time.	Go to sensor (pass through) late jam service check. See <b>“Sensor (pass through) late jam service check” on page 2-145.</b>
245.06	Sensor (pass through) late jam Source = Tray 5	The media is late reaching the sensor (pass through) within the specified time.	Go to sensor (pass through) late jam service check. See <b>“Sensor (pass through) late jam service check” on page 2-145.</b>

Error code or message	Error contents	Description/Action	Possible repair actions
245.08	Sensor (pass through) lingering jam Source = Tray 5	Media reached the sensor (pass through) within the specified time but did not clear it within the specified time.	Go to sensor (pass through) lingering jam service check. See <b>“Sensor (pass through) lingering jam service check.”</b> on page 2-146.
245.10	Sensor (pass through) late jam Source = Tray 5	The media is late reaching the sensor (pass through) within the specified time.	Go to sensor (pass through) late jam service check. See <b>“Sensor (pass through) late jam service check”</b> on page 2-145.
245.13	Sensor (pass through) static jam Source = Tray 5	Media remains on the sensor (input) during the warm up sequence.	Go to sensor (pass through) static jam service check. See <b>“Sensor (pass through) static jam service check”</b> on page 2-147.
245.16	Sensor (pass through) late jam Source = Tray 5	The media is late reaching the sensor (pass through) within the specified time.	Go to sensor (pass through) late jam service check. See <b>“Sensor (pass through) late jam service check”</b> on page 2-145.
245.17	Media tray pulled jam Source = Tray 5	A media tray above the source tray was pulled during the printing process.	<ol style="list-style-type: none"> <li>1. Remove all media present in media path.</li> <li>2. Close all media trays.</li> </ol>
245.18	Pick retry timeout Source = Tray 5	The engine timed out waiting for the tray 5 to report ready before the first pick attempt.	Turn the machine off/on.
245.19	Pick retry timeout Source = Tray 5	The engine timed out waiting for the tray 5 to report ready before a pick retry attempt.	Turn the machine off/on.
245.33	Tray 5 not ready Source = Tray 5	Tray was not properly pushed into the machine.	<ol style="list-style-type: none"> <li>1. Check the size sensing fingers on the media tray for damage</li> <li>2. Replace the media tray assembly if problem remains.</li> <li>3. Check the switch (media size) for proper connection.</li> <li>4. Replace the switch (media size) if problem remains. Go to <b>“Switch (media size) assembly removal (T650, T652, T654)”</b> on page 4-74.</li> </ol>
245.34	Empty tray pick attempted Source = Tray 5	The pick arm attempted to pick with no media in the tray.	<ol style="list-style-type: none"> <li>1. Check the media out actuator for damage.</li> <li>2. Replace the media out actuator if problem remains. Go to <b>“Tray roller catch assembly removal (T650, T652, T654)”</b> on page 4-81.</li> </ol>

Error code or message	Error contents	Description/Action	Possible repair actions
245.35	Pick page received while POR not yet done. Source = Tray 5	Media remains on the sensor (input) during the warm up sequence.	Go to sensor (pass through) static jam service check. See <b>“Sensor (pass through) static jam service check” on page 2-147.</b>
345.36	Sensor (pass through) static jam Source = Tray 5	Media remains on the sensor (input) during the warm up sequence.	Go to sensor (pass through) static jam service check. See <b>“Sensor (pass through) static jam service check” on page 2-147.</b>
245.37	Sensor (pass through) late jam Source = Tray 5	The media is late reaching the sensor (pass through) within the specified time.	Go to sensor (pass through) late jam service check. See <b>“Sensor (pass through) late jam service check” on page 2-145.</b>
245.39	Media tray pulled jam Source = Tray 5	A media tray above the source tray was pulled during the printing process.	<ol style="list-style-type: none"> <li>1. Remove all media present in media path.</li> <li>2. Close all media trays.</li> </ol>
245.40	Sensor (pass through) lingering jam Source = Tray 5	Media reached the sensor (pass through) within the specified time but did not clear it within the specified time.	Go to sensor (pass through) lingering jam service check. See <b>“Sensor (pass through) lingering jam service check.” on page 2-146.</b>
245.49	HCIT tray lift motor stalled failure Source = Tray 5	The HCIT tray lift motor has stalled or has become obstructed.	<ol style="list-style-type: none"> <li>1. Ensure the HCIT media tray assembly is properly inserted into the machine.</li> <li>2. Check the HCIT tray lift motor assembly for binding or damage.</li> <li>3. Replace the HCIT tray lift drive motor assembly if problem remains.</li> </ol> <p>Go to <b>“High capacity input tray (HCIT) tray lift drive motor assembly removal” on page 4-125.</b></p>
245.50	HCIT tray lift motor underspeed failure Source = Tray 5	The HCIT tray lift motor does not rotate at the specified speed.	<ol style="list-style-type: none"> <li>1. Ensure the HCIT media tray assembly is properly inserted into the machine.</li> <li>2. Check the HCIT tray lift motor assembly for binding or damage.</li> <li>3. Replace the HCIT tray lift drive motor assembly if problem remains.</li> </ol> <p>Go to <b>“High capacity input tray (HCIT) tray lift drive motor assembly removal” on page 4-125.</b></p>

Error code or message	Error contents	Description/Action	Possible repair actions
245.52	HCIT tray lift motor overrun failure Source = Tray 5	The HCIT tray lift motor continues to detect pulses after the motor has turned off.	<ol style="list-style-type: none"> <li>1. Ensure the HCIT media tray assembly is properly inserted into the machine.</li> <li>2. Check the HCIT tray lift motor assembly for binding or damage.</li> <li>3. Replace the HCIT tray lift drive motor assembly if problem remains.</li> </ol> <p>Go to <b>“High capacity input tray (HCIT) tray lift drive motor assembly removal” on page 4-125.</b></p>
245.65	Pick motor load error Source = Media tray 5	The pick motor has failed or caused high mechanical load due to paper jam or bind.	<ol style="list-style-type: none"> <li>1. Remove all media present in media path.</li> <li>2. Ensure media tray is not overfilled.</li> <li>3. Check, clean or replace the pick rolls for wear and excess contamination. Go to <b>“Pick roll assembly removal (T650, T652, T654)” on page 4-57.</b></li> <li>4. Check all connections on the pick arm assembly.</li> <li>5. Check all connections on the system card assembly.</li> <li>6. Replace the pick arm assembly if problem remains. Go to <b>“Operator panel door assembly removal (models X651, X652, X654, and X656)” on page 4-49.</b></li> <li>7. Replace system card assembly if problem remains. Go to <b>“System card assembly removal (T650, T652, T654, T656)” on page 4-76.</b></li> </ol>

Error code or message	Error contents	Description/Action	Possible repair actions
245.66	Pick motor underspeed failure Source = Media tray 5	The pick motor does not rotate at the specified speed.	<ol style="list-style-type: none"> <li>1. Remove all media present in media path.</li> <li>2. Ensure media tray is not overfilled.</li> <li>3. Check all connections on the pick arm assembly.</li> <li>4. Check all connections on the system card assembly.</li> <li>5. Replace the pick arm assembly if problem remains. Go to <b>“Operator panel door assembly removal (models X651, X652, X654, and X656)” on page 4-49.</b></li> <li>6. Replace system card assembly if problem remains. Go to <b>“System card assembly removal (T650, T652, T654, T656)” on page 4-76.</b></li> </ol>
245.67	Pick motor overspeed failure Source = Media tray 5	The pick motor does not rotate at the specified speed.	<ol style="list-style-type: none"> <li>1. Remove all media present in media path.</li> <li>2. Ensure media tray is not overfilled.</li> <li>3. Check all connections on the pick arm assembly.</li> <li>4. Check all connections on the system card assembly.</li> <li>5. Replace the pick arm assembly if problem remains. Go to <b>“Operator panel door assembly removal (models X651, X652, X654, and X656)” on page 4-49.</b></li> <li>6. Replace system card assembly if problem remains. Go to <b>“System card assembly removal (T650, T652, T654, T656)” on page 4-76.</b></li> </ol>

Error code or message	Error contents	Description/Action	Possible repair actions
245.68	Pick motor stop error Source = Media tray 5	Pick motor stop error detected by options tray x	<ol style="list-style-type: none"> <li>1. Remove all media present in media path.</li> <li>2. Ensure media tray is not overfilled.</li> <li>3. Check all connections on the pick arm assembly.</li> <li>4. Check all connections on the system card assembly.</li> <li>5. Replace the pick arm assembly if problem remains. Go to <b>“Operator panel door assembly removal (models X651, X652, X654, and X656)” on page 4-49.</b></li> <li>6. Replace system card assembly if problem remains. Go to <b>“System card assembly removal (T650, T652, T654, T656)” on page 4-76.</b></li> </ol>
245.69	Pick motor control failure. Source = Media tray 5	The pick motor does not reach the proper operating speed at the specified time.	<ol style="list-style-type: none"> <li>1. Remove all media present in media path.</li> <li>2. Ensure media tray is not overfilled.</li> <li>3. Check all connections on the pick arm assembly.</li> <li>4. Check all connections on the system card assembly.</li> <li>5. Replace the pick arm assembly if problem remains. Go to <b>“Operator panel door assembly removal (models X651, X652, X654, and X656)” on page 4-49.</b></li> <li>6. Replace system card assembly if problem remains. Go to <b>“System card assembly removal (T650, T652, T654, T656)” on page 4-76.</b></li> </ol>
250.00	MPF area jam Source = MPF	The media is jammed in the MPF area.	Go to sensor (input) service check. See <b>“Sensor (input) service check” on page 2-126.</b>
250.03	Sensor (input) late jam Source = MPF	The media is late reaching the sensor (input) within the specified time.	Go to sensor (input) late jam service check. See <b>“Sensor (input) late jam service check.” on page 2-129.</b>
250.06	Sensor (input) late jam Source = MPF	The media is late reaching the sensor (input) within the specified time.	Go to sensor (input) late jam service check. See <b>“Sensor (input) late jam service check.” on page 2-129.</b>



Error code or message	Error contents	Description/Action	Possible repair actions
250.07	Sensor (input) late jam Source = MPF	The media is late reaching the sensor (input) within the specified time.	Go to sensor (input) late jam service check. See <b>“Sensor (input) late jam service check.” on page 2-129.</b>
250.08	Sensor (input) late jam Source = MPF	The media is late reaching the sensor (input) within the specified time.	Go to sensor (input) late jam service check. See <b>“Sensor (input) late jam service check.” on page 2-129.</b>
250.09	Sensor (input) late jam Source = MPF	The media is late reaching the sensor (input) within the specified time.	Go to sensor (input) late jam service check. See <b>“Sensor (input) late jam service check.” on page 2-129.</b>
250.10	Sensor (input) late jam Source = MPF	The media is late reaching the sensor (input) within the specified time.	Go to sensor (input) late jam service check. See <b>“Sensor (input) late jam service check.” on page 2-129.</b>
250.11	Sensor (input) late jam Source = MPF	The media is late reaching the sensor (input) within the specified time.	Go to sensor (input) late jam service check. See <b>“Sensor (input) late jam service check.” on page 2-129.</b>
260.00	Envelope feeder area jam	The media is jammed in the envelope feeder area.	<ol style="list-style-type: none"> <li>1. Remove the envelope feeder.</li> <li>2. Remove all media present in media path.</li> <li>3. Check media for proper installation.</li> <li>4. Check for obstructions in media path.</li> <li>5. Go to sensor (input) service check. See <b>“Sensor (input) service check” on page 2-126.</b></li> </ol>
260.01	Envelope feeder assembly error	Mechanical feed error or timing error.	<ol style="list-style-type: none"> <li>1. Remove the envelope feeder.</li> <li>2. Remove all media present in media path.</li> <li>3. Check media for proper installation.</li> <li>4. Check for obstructions in media path.</li> <li>5. Ensure the envelope feeder assembly is properly installed.</li> <li>6. Check all connections on the envelope feeder assembly.</li> <li>7. Replace the envelope feeder assembly if problem remains.</li> </ol>

Error code or message	Error contents	Description/Action	Possible repair actions
260.02	Envelope feeder assembly error	Mechanical feed error or timing error.	<ol style="list-style-type: none"> <li>1. Remove the envelope feeder.</li> <li>2. Remove all media present in media path.</li> <li>3. Check media for proper installation.</li> <li>4. Check for obstructions in media path.</li> <li>5. Ensure the envelope feeder assembly is properly installed.</li> <li>6. Check all connections on the envelope feeder assembly.</li> <li>7. Replace the envelope feeder assembly if problem remains.</li> </ol>
260.05	Sensor (envelope feeder pass through) lingering jam Source = Envelope feeder	The media reached the sensor (envelope feeder pass through) but did not clear it in the specified time.	<ol style="list-style-type: none"> <li>1. Remove the envelope feeder.</li> <li>2. Remove all media present in media path.</li> <li>3. Check for obstructions in media path.</li> <li>4. Ensure the envelope feeder assembly is properly installed.</li> <li>5. Check all connections on the envelope feeder assembly.</li> <li>6. Replace the envelope feeder assembly if problem remains.</li> </ol>
260.06	Sensor (envelope feeder pass through) late jam Source = Envelope feeder	The media is late reaching the sensor (envelope feeder pass through) within the specified time.	<ol style="list-style-type: none"> <li>1. Remove the envelope feeder.</li> <li>2. Remove all media present in media path.</li> <li>3. Ensure envelope feeder is not overfilled.</li> <li>4. Check, clean or replace the envelope feeder pick roll for wear and excess contamination.</li> <li>5. Check all connections on the envelope feeder.</li> <li>6. Check all connections on the system card assembly.</li> <li>7. Replace the envelope feeder assembly if problem remains.</li> <li>8. Replace system card assembly if problem remains. Go to <b>“System card assembly removal (T650, T652, T654, T656)” on page 4-76.</b></li> </ol>

Error code or message	Error contents	Description/Action	Possible repair actions
260.07	Sensor (input) late jam Source = Envelope feeder	The media is late reaching the sensor (input) within the specified time.	Go to sensor (input) late jam service check. See <b>“Sensor (input) late jam service check.”</b> on page 2-129.
260.10	Sensor (input) late jam Source = Envelope feeder	The media is late reaching the sensor (input) within the specified time.	Go to sensor (input) late jam service check. See <b>“Sensor (input) late jam service check.”</b> on page 2-129.
260.11	Sensor (input) late jam Source = Envelope feeder	The media is late reaching the sensor (input) within the specified time.	Go to sensor (input) late jam service check. See <b>“Sensor (input) late jam service check.”</b> on page 2-129.
260.12	Sensor (input) late jam Source = Envelope feeder	The media is late reaching the sensor (input) within the specified time.	Go to sensor (input) late jam service check. See <b>“Sensor (input) late jam service check.”</b> on page 2-129.
260.13	sensor (envelope feeder pass through) static jam	Media remains on the sensor (envelope feeder pass through) during the warm up sequence.	<ol style="list-style-type: none"> <li>1. Remove the envelope feeder.</li> <li>2. Remove all media present in media path.</li> <li>3. Replace the envelope feeder if problem remains.</li> </ol>
260.14	Sensor (input) late jam Source = Envelope feeder	The media is late reaching the sensor (input) within the specified time.	Go to sensor (input) late jam service check. See <b>“Sensor (input) late jam service check.”</b> on page 2-129.
260.15	Sensor (input) late jam Source = Envelope feeder	The media is late reaching the sensor (input) within the specified time.	Go to sensor (input) late jam service check. See <b>“Sensor (input) late jam service check.”</b> on page 2-129.
260.16	Sensor (input) late jam Source = Envelope feeder	The media is late reaching the sensor (input) within the specified time.	Go to sensor (input) late jam service check. See <b>“Sensor (input) late jam service check.”</b> on page 2-129.
271.03 x = bin number	Sensor (output pass through) lingering jam Applies to: High capacity output Output expander	The media reached the sensor (output pass through) but did not clear it in the specified time.	See <b>“Sensor (output pass through) lingering jam service check.”</b> on page 2-151.

Error code or message	Error contents	Description/Action	Possible repair actions
271.04 x = bin number	Sensor (output pass through) late jam Applies to: High capacity output Output expander	The media is late reaching the sensor (output pass through) within the specified time.	See <b>“Sensor (output pass through) late jam service check” on page 2-150.</b>
271.05 x = bin number	Sensor (output pass through) lingering jam Applies to: High capacity output Output expander	The media reached the sensor (output pass through) but did not clear it in the specified time.	See <b>“Sensor (output pass through) lingering jam service check” on page 2-151.</b>
27x.14 x = bin number	Sensor (output pass through) static jam Applies to: High capacity stacker Mailbox Offset stacker Output expander  Sensor (mailbox empty) static jam Applies to: Mailbox	Media remains on the sensor (output pass through) during the warm up sequence.  Media remains on the sensor (mailbox empty) during the warm up sequence.	See <b>“Sensor (output pass through) static jam service check” on page 2-152.</b>  See <b>“Sensor (mailbox empty) static jam service check” on page 2-154.</b>
27x.15 x = bin number	Sensor (output pass through) static jam Applies to: High capacity stacker Mailbox Offset stacker Output expander  Sensor (mailbox empty) static jam Applies to: Mailbox	Media remains on the sensor (output pass through) during the warm up sequence.  Media remains on the sensor (mailbox empty) during the warm up sequence.	See <b>“Sensor (output pass through) static jam service check” on page 2-152.</b>  See <b>“Sensor (mailbox empty) static jam service check” on page 2-154.</b>
27x.29 x = bin number	Sensor (output pass through) lingering jam Applies to: Offset stacker Mailbox Output expander High capacity stacker	The media reached the sensor (output pass through) but did not clear it in the specified time.	See <b>“Sensor (output pass through) lingering jam service check” on page 2-151.</b>

Error code or message	Error contents	Description/Action	Possible repair actions
27x.50 x = bin number	Sensor (output pass through) lingering jam Applies to: Mailbox	The media reached the sensor (output pass through) but did not clear it in the specified time.	See <b>“Sensor (output pass through) lingering jam service check” on page 2-151.</b>
27x.50 x = bin number	Left tamper does not leave home position failure Applies to: Offset stacker	The sensor (left tamper HP) does not detect that the tamper has moved from home position.	<ol style="list-style-type: none"> <li>1. Check all the connections on the output option controller card.</li> <li>2. Check the tamper drive belt for damage and replace if needed.</li> <li>3. Replace the left tamper motor assembly. Go to <b>“SFP stapler assembly tamper drive motor assembly removal” on page 4-180.</b></li> <li>4. Replace the sensor (tamper HP). Go to <b>“SFP stapler assembly sensor (tamper HP left and right) removal” on page 4-187.</b></li> <li>4. Replace the output option if problem remains.</li> </ol>
27x.51 x = bin number	Sensor (output pass through) late jam Applies to: Mailbox	The media is late reaching the sensor (output pass through) within the specified time.	See <b>“Sensor (output pass through) late jam service check” on page 2-150</b>
27x.51 x = bin number	Right tamper does not leave home position failure Applies to: Offset stacker	The sensor (right tamper HP) does not detect that the tamper has moved from home position.	<ol style="list-style-type: none"> <li>1. Check all the connections on the output option controller card.</li> <li>2. Check the tamper drive belt for damage and replace if needed.</li> <li>3. Replace the right tamper motor assembly. Go to <b>“SFP stapler assembly tamper drive motor assembly removal” on page 4-180.</b></li> <li>4. Replace the sensor (tamper HP). Go to <b>“SFP stapler assembly sensor (tamper HP left and right) removal” on page 4-187.</b></li> <li>4. Replace the output option if problem remains.</li> </ol>
271.52 x = bin number	Sensor (mailbox empty) lingering jam Applies to: Mailbox	The media reached the sensor (mailbox empty) but did not clear it in the specified time.	See <b>“Sensor (mailbox empty) lingering jam service check” on page 2-154.</b>

<b>Error code or message</b>	<b>Error contents</b>	<b>Description/Action</b>	<b>Possible repair actions</b>
27x.53 x = bin number	Sensor (mailbox empty) late jam Applies to: Mailbox	The media is late reaching the sensor (mailbox empty) within the specified time.	See <b>“Sensor (mailbox empty) late jam service check” on page 2-153</b>
27x.54 x = bin number	Sensor (output pass through) lingering jam Applies to: Mailbox	The media reached the sensor (output pass through) but did not clear it in the specified time.	See <b>“Sensor (output pass through) lingering jam service check” on page 2-151.</b>
27x.55 x = bin number	Sensor (mailbox empty) lingering jam Applies to: Mailbox	The media reached the sensor (mailbox empty) but did not clear it in the specified time.	See <b>“Sensor (mailbox empty) lingering jam service check” on page 2-154.</b>
27x.58 x = bin number	Sensor (output pass through) late jam Applies to: Mailbox High capacity stacker Offset stacker Output expander	The media is late reaching the sensor (output pass through) within the specified time.	See <b>“Sensor (output pass through) late jam service check” on page 2-150.</b>
28x.25 x = bin number	Invalid ejector motor manager status. Applies to: StapleSmart finisher	A software failure has occurred with the output option.	1. Turn the machine off/on. 2. Replace the output option if problem remains.
28x.26 x = bin number	Timer 0 overflow (1 ms timer did not get serviced for an entire 1 ms) Applies to: StapleSmart finisher	A software failure has occurred with the output option.	1. Turn the machine off/on. 2. Replace the output option if problem remains.
28x.27 x = bin number	Invalid paddle motor manager status. Applies to: StapleSmart finisher	A software failure has occurred with the output option.	1. Turn the machine off/on. 2. Replace the output option if problem remains.
28x.28 x = bin number	Invalid main motor manager state Applies to: StapleSmart finisher	A software failure has occurred with the output option.	1. Turn the machine off/on. 2. Replace the output option if problem remains.
28x.29 x = bin number	Sensor (stapler pass through) lingering jam Applies to: StapleSmart finisher	The media reached the sensor (stapler pass through) but did not clear it in the specified time.	See <b>“Sensor (stapler pass through) lingering jam service check” on page 2-149.</b>

Error code or message	Error contents	Description/Action	Possible repair actions
28x.30 x = bin number	Page ID complete not clear Applies to: StapleSmart finisher	A software failure has occurred with the output option.	1. Turn the machine off/on. 2. Replace the output option if problem remains.
28x.31 x = bin number	Transport motor encoder not detected Applies to: StapleSmart finisher	The output option transport motor encoder is not detected upon startup.	1. Check all connections on the output option controller card. 2. Replace the output option if problem remains.
28x.32 x = bin number	Transport motor encoder not detected Applies to: StapleSmart finisher	The transport motor encoder detection is lost during normal operation.	1. Check all connections on the output option controller card. 2. Replace the output option if problem remains.
28x.33 x = bin number	Transport motor overspeed failure Applies to: StapleSmart finisher	The transport motor rotate at the specified speed	1. Check all connections on the output option controller card. 2. Replace the output option if problem remains.
28x.34 x = bin number	Transport motor underspeed failure Applies to: StapleSmart finisher	The transport motor rotate at the specified speed	1. Check all connections on the output option controller card. 2. Replace the output option if problem remains.
28x.35 x = bin number	Sensor (self priming) late failure Applies to: StapleSmart finisher	The sensor (self priming) within the stapler assembly does not detect a ready staple in the specified time.	1. Check all the connections on the output option controller card and the stapler assembly. 2. Remove the staple cartridge and remove all jammed staples. If the cartridge is jammed and can not be removed, go to step 3. 3. Remove the stapler assembly. Go to <b>“SFP stapler assembly stapler unit assembly removal” on page 4-182.</b> 4. Manually rotate the drive gears and reset the stapler. Remove all jammed staples then reinstall the stapler assembly. 5. If problem remains, replace the stapler assembly. Go to <b>“SFP stapler assembly stapler unit assembly removal” on page 4-182.</b>

Error code or message	Error contents	Description/Action	Possible repair actions
28x.36 x = bin number	Stapler drive motor jammed Applies to: StapleSmart finisher	The stapler assembly has jammed while stapling or the stapler drive motor has failed.	<ol style="list-style-type: none"> <li>1. Check all the connections on the controller card and the stapler assembly.</li> <li>2. Remove the staple cartridge and remove all jammed staples. If the cartridge is jammed and can not be removed, go to step 3.</li> <li>3. Remove the stapler assembly. Go to <b>“SFP stapler assembly stapler unit assembly removal” on page 4-182.</b></li> <li>4. Manually rotate the drive gears and reset the stapler. Remove all jammed staples then reinstall the stapler assembly.</li> <li>5. If problem remains, replace the stapler assembly. Go to <b>“SFP stapler assembly stapler unit assembly removal” on page 4-182.</b></li> </ol>
28x.37 x = bin number	Invalid tamper motor manager status Applies to: StapleSmart finisher	A software failure has occurred with the output option.	<ol style="list-style-type: none"> <li>1. Turn the machine off/on.</li> <li>2. Replace the output option if problem remains.</li> </ol>
28x.38 x = bin number	Staple ready home position jam Applies to: StapleSmart finisher	The sensor (self priming) within the stapler assembly does not detect a ready staple in the specified time after the staple job was sent.	<ol style="list-style-type: none"> <li>1. Check all the connections on the controller card and the stapler assembly.</li> <li>2. Remove the staple cartridge and remove all jammed staples. If the cartridge is jammed and can not be removed, go to step 3.</li> <li>3. Remove the stapler assembly. Go to <b>“SFP stapler assembly stapler unit assembly removal” on page 4-182.</b></li> <li>4. Manually rotate the drive gears and reset the stapler. Remove all jammed staples then reinstall the stapler assembly.</li> <li>5. If problem remains, replace the stapler assembly. Go to <b>“SFP stapler assembly stapler unit assembly removal” on page 4-182.</b></li> </ol>



Error code or message	Error contents	Description/Action	Possible repair actions
28x.39 x = bin number	Staple ready home position jam Applies to: StapleSmart finisher	The sensor (self priming) within the stapler assembly does not detect a ready staple in the specified time during mechanical reset.	<ol style="list-style-type: none"> <li>1. Check all the connections on the controller card and the stapler assembly.</li> <li>2. Remove the staple cartridge and remove all jammed staples. If the cartridge is jammed and can not be removed, go to step 3.</li> <li>3. Remove the stapler assembly. Go to <b>“SFP stapler assembly stapler unit assembly removal” on page 4-182.</b></li> <li>4. Manually rotate the drive gears and reset the stapler. Remove all jammed staples then reinstall the stapler assembly.</li> <li>5. If problem remains, replace the stapler assembly. Go to <b>“SFP stapler assembly stapler unit assembly removal” on page 4-182.</b></li> </ol>
28x.40 x = bin number	Left tamper does not leave home position failure Applies to: StapleSmart finisher	The sensor (left tamper HP) does not detect that the tamper has moved from home position.	<ol style="list-style-type: none"> <li>1. Check all the connections on the output option controller card.</li> <li>2. Check the tamper drive belt for damage and replace if needed.</li> <li>3. Replace the left tamper motor assembly. Go to <b>“SFP stapler assembly tamper drive motor assembly removal” on page 4-180.</b></li> <li>4. Replace the sensor (tamper HP). Go to <b>“SFP stapler assembly sensor (tamper HP left and right) removal” on page 4-187.</b></li> <li>4. Replace the output option if problem remains.</li> </ol>

Error code or message	Error contents	Description/Action	Possible repair actions
28x.41 x = bin number	Left tamper does not move to home position failure. Applies to: StapleSmart finisher	The sensor (left tamper HP) does not detect that the tamper has reached home position.	<ol style="list-style-type: none"> <li>1. Check all the connections on the output option controller card.</li> <li>2. Check the tamper drive belt for damage and replace if needed.</li> <li>3. Replace the left tamper motor assembly.</li> </ol> <p>Go to <b>“SFP stapler assembly tamper drive motor assembly removal” on page 4-180.</b></p> <ol style="list-style-type: none"> <li>4. Replace the sensor (tamper HP).</li> </ol> <p>Go to <b>“SFP stapler assembly sensor (tamper HP left and right) removal” on page 4-187.</b></p> <ol style="list-style-type: none"> <li>4. Replace the output option if problem remains.</li> </ol>
28x.42 x = bin number	Right tamper does not leave home position failure Applies to: StapleSmart finisher	The sensor (right tamper HP) does not detect that the tamper has moved from home position.	<ol style="list-style-type: none"> <li>1. Check all the connections on the output option controller card.</li> <li>2. Check the tamper drive belt for damage and replace if needed.</li> <li>3. Replace the right tamper motor assembly.</li> </ol> <p>Go to <b>“SFP stapler assembly tamper drive motor assembly removal” on page 4-180.</b></p> <ol style="list-style-type: none"> <li>4. Replace the sensor (tamper HP).</li> </ol> <p>Go to <b>“SFP stapler assembly sensor (tamper HP left and right) removal” on page 4-187.</b></p> <ol style="list-style-type: none"> <li>4. Replace the output option if problem remains.</li> </ol>

Error code or message	Error contents	Description/Action	Possible repair actions
28x.43 x = bin number	Right tamper does not move to home position failure. Applies to: StapleSmart finisher	The sensor (right tamper HP) does not detect that the tamper has reached home position.	<ol style="list-style-type: none"> <li>1. Check all the connections on the output option controller card.</li> <li>2. Check the tamper drive belt for damage and replace if needed.</li> <li>3. Replace the right tamper motor assembly.</li> </ol> <p>Go to <b>“SFP stapler assembly tamper drive motor assembly removal” on page 4-180.</b></p> <ol style="list-style-type: none"> <li>4. Replace the sensor (tamper HP).</li> </ol> <p>Go to <b>“SFP stapler assembly sensor (tamper HP left and right) removal” on page 4-187.</b></p> <ol style="list-style-type: none"> <li>4. Replace the output option if problem remains.</li> </ol>
28x.44 x = bin number	Eject home position jam Applies to: StapleSmart finisher	The sensor (eject HP) does not detect that the eject mechanism is operating.	<ol style="list-style-type: none"> <li>1. Check all the connections on the output option controller card.</li> <li>2. Replace the output option if problem remains.</li> </ol>
28x.45 x = bin number	Eject home position jam Applies to: StapleSmart finisher	The sensor (eject HP) does not detect the home position upon completion of normal media eject operation.	<ol style="list-style-type: none"> <li>1. Check all the connections on the output option controller card.</li> <li>2. Replace the output option if problem remains.</li> </ol>
28x.46 x = bin number	Paddle home position jam Applies to: StapleSmart finisher	The sensor (paddle HP) does not detect that the paddle is operating.	<ol style="list-style-type: none"> <li>1. Check all the connections on the output option controller card.</li> <li>2. Check the sensor (paddle HP) for damage and replace if needed.</li> </ol> <p>Go to <b>“SFP stapler assembly sensor (paddle HP) removal” on page 4-185.</b></p> <ol style="list-style-type: none"> <li>3. Replace the output option if problem remains.</li> </ol>
28x.47 x = bin number	Paddle home position jam Applies to: StapleSmart finisher	The sensor (paddle HP) does not detect the home position upon completion of normal paddle operation.	<ol style="list-style-type: none"> <li>1. Check all the connections on the output option controller card.</li> <li>2. Check the sensor (paddle HP) for damage and replace if needed.</li> </ol> <p>Go to <b>“SFP stapler assembly sensor (paddle HP) removal” on page 4-185.</b></p> <ol style="list-style-type: none"> <li>3. Replace the output option if problem remains.</li> </ol>

Error code or message	Error contents	Description/Action	Possible repair actions
28x.48 x = bin number	Deflector gate transition to output option not detected Applies to: StapleSmart finisher	The sensor (deflector gate HP) does not detect transition of the deflector gate to the output option.	<ol style="list-style-type: none"> <li>1. Check all the connections on the output option controller card.</li> <li>2. Check the sensor (deflector HP) for damage and replace if needed.</li> </ol> <p>Go to <b>“SFP stapler assembly sensor (deflector HP) removal” on page 4-190.</b></p> <ol style="list-style-type: none"> <li>3. Replace the output option if problem remains.</li> </ol>
28x.49 x = bin number	Deflector gate transition to standard bin not detected Applies to: StapleSmart finisher	The sensor (deflector gate HP) does not detect transition of the deflector gate to the standard bin.	<ol style="list-style-type: none"> <li>1. Check all the connections on the output option controller card.</li> <li>2. Check the sensor (deflector HP) for damage and replace if needed.</li> </ol> <p>Go to <b>“SFP stapler assembly sensor (deflector HP) removal” on page 4-190.</b></p> <ol style="list-style-type: none"> <li>3. Replace the output option if problem remains.</li> </ol>
28x.50 x = bin number	Left tamper home position jam Applies to: StapleSmart finisher	The left tamper home position is not detected by the sensor (left tamper HP)	<ol style="list-style-type: none"> <li>1. Check all the connections on the output option controller card.</li> <li>2. Check the tamper drive belt for damage and replace if needed.</li> <li>3. Replace the left tamper motor assembly.</li> </ol> <p>Go to <b>“SFP stapler assembly tamper drive motor assembly removal” on page 4-180.</b></p> <ol style="list-style-type: none"> <li>4. Replace the sensor (tamper HP).</li> </ol> <p>Go to <b>“SFP stapler assembly sensor (tamper HP left and right) removal” on page 4-187.</b></p> <ol style="list-style-type: none"> <li>4. Replace the output option if problem remains.</li> </ol>

Error code or message	Error contents	Description/Action	Possible repair actions
28x.51 x = bin number	Right tamper home position jam Applies to: StapleSmart finisher	The right tamper home position is not detected by the sensor (right tamper HP)	<ol style="list-style-type: none"> <li>1. Check all the connections on the output option controller card.</li> <li>2. Check the tamper drive belt for damage and replace if needed.</li> <li>3. Replace the right tamper motor assembly.</li> </ol> <p>Go to <b>“SFP stapler assembly tamper drive motor assembly removal” on page 4-180.</b></p> <ol style="list-style-type: none"> <li>4. Replace the sensor (tamper HP).</li> </ol> <p>Go to <b>“SFP stapler assembly sensor (tamper HP left and right) removal” on page 4-187.</b></p> <ol style="list-style-type: none"> <li>4. Replace the output option if problem remains.</li> </ol>
28x.52 x = bin number	Paddle control motor timer error Applies to: StapleSmart finisher	A software failure has occurred with the output option.	<ol style="list-style-type: none"> <li>1. Turn the machine off/on.</li> <li>2. Replace the output option if problem remains.</li> </ol>
28x.53 x = bin number	Eject motor encoder not detected Applies to: StapleSmart finisher	The eject motor encoder is not detected upon startup	<ol style="list-style-type: none"> <li>1. Check all the connections on the output option controller card.</li> <li>2. Replace the output option if problem remains.</li> </ol>
28x.54 x = bin number	Eject motor encoder not detected Applies to: StapleSmart finisher	The eject motor encoder detection is lost during normal operation.	<ol style="list-style-type: none"> <li>1. Check all the connections on the output option controller card.</li> <li>2. Replace the output option if problem remains.</li> </ol>
28x.55 x = bin number	Eject motor overspeed failure Applies to: StapleSmart finisher	The eject motor rotate at the specified speed	<ol style="list-style-type: none"> <li>1. Check all the connections on the output option controller card.</li> <li>2. Replace the output option if problem remains.</li> </ol>
28x.56 x = bin number	Eject motor underspeed failure Applies to: StapleSmart finisher	The eject motor rotate at the specified speed	<ol style="list-style-type: none"> <li>1. Check all the connections on the output option controller card.</li> <li>2. Replace the output option if problem remains.</li> </ol>
28x.57 x = bin number	Sensor (stapler pass through) static jam Applies to: StapleSmart finisher	Media remains on the sensor (stapler pass through) during the warm up sequence.	<p>Go to sensor (stapler pass through) static jam service check.</p> <p>See <b>“Sensor (stapler pass through) static jam service check” on page 2-149.</b></p>

Error code or message	Error contents	Description/Action	Possible repair actions
28x.58 x = bin number	Sensor (stapler pass through) late jam StapleSmart finisher	The media is late reaching the sensor (stapler pass through) within the specified time.	See <b>“Sensor (output pass through) late jam service check” on page 2-150.</b>
28x.59 x = bin number	Staple ready home position jam Applies to: StapleSmart finisher	The sensor (self priming) within the stapler assembly does not detect a ready staple in the specified time after the staple job was sent.	<ol style="list-style-type: none"> <li>1. Check all the connections on the controller card and the stapler assembly.</li> <li>2. Remove the staple cartridge and remove all jammed staples. If the cartridge is jammed and can not be removed, go to step 3.</li> <li>3. Remove the stapler assembly.</li> </ol> <p>Go to <b>“SFP stapler assembly stapler unit assembly removal” on page 4-182.</b></p> <ol style="list-style-type: none"> <li>4. Manually rotate the drive gears and reset the stapler. Remove all jammed staples then reinstall the stapler assembly.</li> <li>5. If problem remains, replace the stapler assembly.</li> </ol> <p>Go to <b>“SFP stapler assembly stapler unit assembly removal” on page 4-182.</b></p>
28x.60 x = bin number	The status of stapler motor is not defined Applies to: StapleSmart finisher	A software failure has occurred with the output option.	<ol style="list-style-type: none"> <li>1. Turn the machine off/on.</li> <li>2. Replace the output option if problem remains.</li> </ol>
28x.61 x = bin number	DMID command is not received for 500ms after main motor runs Applies to: StapleSmart finisher	A software failure has occurred with the output option.	<ol style="list-style-type: none"> <li>1. Turn the machine off/on.</li> <li>2. Replace the output option if problem remains.</li> </ol>
28x.62 x = bin number	When finishing job isn't completed yet, the first DMID command of the next job is received. Applies to: StapleSmart finisher	A software failure has occurred with the output option.	<ol style="list-style-type: none"> <li>1. Turn the machine off/on.</li> <li>2. Replace the output option if problem remains.</li> </ol>
28x.63 x = bin number	Bin clamp motor control timer error. Applies to: StapleSmart finisher	A software failure has occurred with the output option.	<ol style="list-style-type: none"> <li>1. Turn the machine off/on.</li> <li>2. Replace the output option if problem remains.</li> </ol>

Error code or message	Error contents	Description/Action	Possible repair actions
28x.64 x = bin number	Bin clamp motor control timer error during tray holder initial.  Applies to: StapleSmart finisher	A software failure has occurred with the output option.	1. Turn the machine off/on. 2. Replace the output option if problem remains.
28x.65 x = bin number	Bin clamp home position jam  Applies to: StapleSmart finisher	The bin clamp home position is not detected by the sensor (bin clamp HP)	1. Turn the machine off/on. 2. Replace the output option if problem remains.
28x.66 x = bin number	Bin clamp home position jam  Applies to: StapleSmart finisher	The sensor (bin clamp HP) does not detect that the bin clamp has moved from home position.	1. Turn the machine off/on. 2. Replace the output option if problem remains.
28x.67 x = bin number	Invalid bin clamp manager state.  Applies to: StapleSmart finisher	A software failure has occurred with the output option.	1. Turn the machine off/on. 2. Replace the output option if problem remains.
28x.68 x = bin number	Staple ready home position jam  Applies to: StapleSmart finisher	The sensor (self priming) within the stapler assembly does not detect a ready staple prior to a staple job.  Staples empty	1. Check all the connections on the controller card and the stapler assembly. 2. Remove the staple cartridge and remove all jammed staples. If the cartridge is jammed and can not be removed, go to step 3. 3. Remove the stapler assembly. Go to <b>“SFP stapler assembly stapler unit assembly removal” on page 4-182.</b> 4. Manually rotate the drive gears and reset the stapler. Remove all jammed staples then reinstall the stapler assembly. 5. If problem remains, replace the stapler assembly. Go to <b>“SFP stapler assembly stapler unit assembly removal” on page 4-182.</b>

Error code or message	Error contents	Description/Action	Possible repair actions
28x.69 x = bin number	Staple ready home position jam Applies to: StapleSmart finisher	The sensor (self priming) within the stapler assembly does not detect a ready staple in the specified time after the staple job was sent. Staples not empty	<ol style="list-style-type: none"> <li>1. Check all the connections on the controller card and the stapler assembly.</li> <li>2. Remove the staple cartridge and remove all jammed staples. If the cartridge is jammed and can not be removed, go to step 3.</li> <li>3. Remove the stapler assembly. Go to <b>“SFP stapler assembly stapler unit assembly removal” on page 4-182.</b></li> <li>4. Manually rotate the drive gears and reset the stapler. Remove all jammed staples then reinstall the stapler assembly.</li> <li>5. If problem remains, replace the stapler assembly. Go to <b>“SFP stapler assembly stapler unit assembly removal” on page 4-182.</b></li> </ol>
28x.70 x = bin number	Stapler mechanism not in home position failure Applies to: StapleSmart finisher	The sensor (home signal) within the stapler assembly detected that the stapler mechanism was not in the home position before stapling.	<ol style="list-style-type: none"> <li>1. Check all the connections on the controller card and the stapler assembly.</li> <li>2. Remove the staple cartridge and remove all jammed staples. If the cartridge is jammed and can not be removed, go to step 3.</li> <li>3. Remove the stapler assembly. Go to <b>“SFP stapler assembly stapler unit assembly removal” on page 4-182.</b></li> <li>4. Manually rotate the drive gears and reset the stapler and remove all jammed staples then reinstall the stapler assembly.</li> <li>5. If problem remains, replace the stapler assembly. Go to <b>“SFP stapler assembly stapler unit assembly removal” on page 4-182.</b></li> </ol>



Error code or message	Error contents	Description/Action	Possible repair actions
28x.71 x = bin number	Deflector gate transition to standard bin not detected Applies to: StapleSmart finisher	The sensor (deflector gate HP) does not detect transition of the deflector gate to the standard bin.	<ol style="list-style-type: none"> <li>1. Check all the connections on the output option controller card.</li> <li>2. Check the sensor (deflector HP) for damage and replace if needed.</li> </ol> <p>Go to <b>“SFP stapler assembly sensor (deflector HP) removal” on page 4-190.</b></p> <ol style="list-style-type: none"> <li>3. Replace the output option if problem remains.</li> </ol>
281.72 x = bin number	Sensor (media in stapler) static jam Applies to: StapleSmart finisher	Media remains on the sensor (media in stapler) during the warm up sequence.	<ol style="list-style-type: none"> <li>1. Inspect the sensor (media in stapler) for proper installation and reinstall if needed.</li> <li>2. Replace the sensor (media in stapler)</li> </ol> <p>Go to <b>“SFP stapler assembly sensor (media in stapler) removal” on page 4-189.</b></p>
900.xx	System software error	Code detected unusual event or timing.	<ol style="list-style-type: none"> <li>1. POR the machine and print a simple test page to determine if the problem is system software related, or if the customer is sending a corrupted print job.</li> <li>2. Check all connections on the system card assembly.</li> <li>3. Replace the system card assembly if problem remains. Go to <b>“System card assembly removal (T650, T652, T654, T656)” on page 4-76.</b></li> </ol>
901xx	System software error	Code detected unusual event or timing.	<ol style="list-style-type: none"> <li>1. POR the machine and print a simple test page to determine if the problem is firmware related, or if the customer is sending a corrupted print job.</li> <li>2. Check all connections on the system card assembly.</li> <li>3. Replace the system card assembly if problem remains. Go to <b>“System card assembly removal (T650, T652, T654, T656)” on page 4-76.</b></li> </ol>

Error code or message	Error contents	Description/Action	Possible repair actions
902.xx	System software error	Code detected unusual event or timing.	<ol style="list-style-type: none"> <li>1. POR the machine and print a simple test page to determine if the problem is system software related, or if the customer is sending a corrupted print job.</li> <li>2. Check all connections on the system card assembly.</li> <li>3. Replace the system card assembly if problem remains. Go to <b>“System card assembly removal (T650, T652, T654, T656)” on page 4-76.</b></li> </ol>
903.xx	Paperport link driver error	Code detected unusual event or timing.	<ol style="list-style-type: none"> <li>1. POR the machine and print a simple test page to determine if the problem is system software related, or if the customer is sending a corrupted print job.</li> <li>2. Check all connections on the system card assembly.</li> <li>3. Replace the system card assembly if problem remains. Go to <b>“System card assembly removal (T650, T652, T654, T656)” on page 4-76.</b></li> </ol>
904.xx	Interface violation by RIP	Code detected unusual event or timing.	<ol style="list-style-type: none"> <li>1. POR the machine and print a simple test page to determine if the problem is system software related, or if the customer is sending a corrupted print job.</li> <li>2. Check all connections on the system card assembly.</li> <li>3. Replace the system card assembly if problem remains. Go to <b>“System card assembly removal (T650, T652, T654, T656)” on page 4-76.</b></li> </ol>
905.xx	Interface violation by paperport device	Code detected unusual event or timing.	<ol style="list-style-type: none"> <li>1. POR the machine and print a simple test page to determine if the problem is system software related, or if the customer is sending a corrupted print job.</li> <li>2. Check all connections on the system card assembly.</li> <li>3. Replace the system card assembly if problem remains. Go to <b>“System card assembly removal (T650, T652, T654, T656)” on page 4-76.</b></li> </ol>

Error code or message	Error contents	Description/Action	Possible repair actions
906.xx	RIP interface driver error	Code detected unusual event or timing.	<ol style="list-style-type: none"> <li>1. POR the machine and print a simple test page to determine if the problem is system software related, or if the customer is sending a corrupted print job.</li> <li>2. Check all connections on the system card assembly.</li> <li>3. Replace the system card assembly if problem remains. Go to <b>“System card assembly removal (T650, T652, T654, T656)” on page 4-76.</b></li> </ol>
910.00	Pick arm motor stalled failure	The pick arm motor has stalled or become obstructed.	<ol style="list-style-type: none"> <li>1. Check all the connections on the pick arm assembly.</li> <li>2. Check all the connections on the system card assembly.</li> <li>3. Replace the pick arm assembly if problem remains.</li> </ol> <p>Go to <b>“Operator panel door assembly removal (models X651, X652, X654, and X656)” on page 4-49.</b></p>
911.00	Pick arm motor overrun failure	The pick arm motor encoder continues to detect pulse after the motor stops.	<ol style="list-style-type: none"> <li>1. Check all the connections on the pick arm assembly.</li> <li>2. Check all the connections on the system card assembly.</li> <li>3. Replace the pick arm assembly if problem remains.</li> </ol> <p>Go to <b>“Operator panel door assembly removal (models X651, X652, X654, and X656)” on page 4-49.</b></p>
912.00	Pick arm motor underspeed failure	The pick arm motor does not rotate at the specified speed.	<ol style="list-style-type: none"> <li>1. Check all the connections on the pick arm assembly.</li> <li>2. Check all the connections on the system card assembly.</li> <li>3. Replace the pick arm assembly if problem remains.</li> </ol> <p>Go to <b>“Operator panel door assembly removal (models X651, X652, X654, and X656)” on page 4-49.</b></p>
913.00	Pick arm motor overspeed failure	The pick arm motor does not rotate at the specified speed.	<ol style="list-style-type: none"> <li>1. Check all the connections on the pick arm assembly.</li> <li>2. Check all the connections on the system card assembly.</li> <li>3. Replace the pick arm assembly if problem remains.</li> </ol> <p>Go to <b>“Operator panel door assembly removal (models X651, X652, X654, and X656)” on page 4-49.</b></p>

Error code or message	Error contents	Description/Action	Possible repair actions
914.00	Pick arm motor no encoder not detected failure	The pick arm motor encoder detection is lost during normal operation	<ol style="list-style-type: none"> <li>1. Check all the connections on the pick arm assembly.</li> <li>2. Check all the connections on the system card assembly.</li> <li>3. Replace the pick arm assembly if problem remains.</li> </ol> <p>Go to <b>“Operator panel door assembly removal (models X651, X652, X654, and X656)” on page 4-49.</b></p>
914.01	Pick arm motor overspeed failure.	The pick arm motor does not rotate at the specified speed.	<ol style="list-style-type: none"> <li>1. Check all the connections on the pick arm assembly.</li> <li>2. Check all the connections on the system card assembly.</li> <li>3. Replace the pick arm assembly if problem remains.</li> </ol> <p>Go to <b>“Operator panel door assembly removal (models X651, X652, X654, and X656)” on page 4-49.</b></p>
915.00	Redrive motor encoder not detected failure	The redrive motor encoder detection is lost during normal operation	<ol style="list-style-type: none"> <li>1. Check all the connections on the duplex drive motor assembly.</li> <li>2. Check all the connections on the system card assembly.</li> <li>3. Replace the duplex drive motor assembly if problem remains.</li> </ol> <p>Go to <b>“Duplex drive motor assembly removal (T652, T654)” on page 4-19.</b></p>
915.01	Redrive motor over speed failure	The redrive motor does not rotate at the specified speed.	<ol style="list-style-type: none"> <li>1. Check all the connections on the duplex drive motor assembly.</li> <li>2. Check all the connections on the system card assembly.</li> <li>3. Replace the duplex drive motor assembly if problem remains.</li> </ol> <p>Go to <b>“Duplex drive motor assembly removal (T652, T654)” on page 4-19.</b></p>
916.00	Internal duplex drive motor encoder not detected failure	The duplex drive motor encoder detection is lost during normal operation	<ol style="list-style-type: none"> <li>1. Check all the connections on the duplex drive motor assembly.</li> <li>2. Check all the connections on the system card assembly.</li> <li>3. Replace the duplex drive motor assembly if problem remains.</li> </ol> <p>Go to <b>“Duplex drive motor assembly removal (T652, T654)” on page 4-19.</b></p>

Error code or message	Error contents	Description/Action	Possible repair actions
916.01	Internal duplex drive motor over speed failure	The duplex drive motor does not rotate at the specified speed.	<ol style="list-style-type: none"> <li>1. Check all the connections on the duplex drive motor assembly.</li> <li>2. Check all the connections on the system card assembly.</li> <li>3. Replace the duplex drive motor assembly if problem remains.</li> </ol> <p>Go to <b>“Duplex drive motor assembly removal (T652, T654)” on page 4-19.</b></p>
920.00	Fuser under temperature Fuser type = 1	Fuser does not maintain proper operating temperature within steady state control.	<ol style="list-style-type: none"> <li>1. Turn the machine off/on and ensure the fuser unit assembly is properly installed.</li> <li>2. Ensure the proper voltage fuser is installed in the machine.</li> <li>3. Replace the fuser unit assembly if problem remains. Go to <b>“Fuser unit assembly removal (T650, T652, T654)” on page 4-23.</b></li> </ol>
920.01	Fuser warm-up failure Fuser type = 1	The fuser hot roll took too long to heat up after transitioning to new enhanced mode within standby control only.	<ol style="list-style-type: none"> <li>1. Turn the machine off/on and ensure the fuser unit assembly is properly installed.</li> <li>2. Ensure the proper voltage fuser is installed in the machine.</li> <li>3. Replace the fuser unit assembly if problem remains. Go to <b>“Fuser unit assembly removal (T650, T652, T654)” on page 4-23.</b></li> </ol>
920.02	Fuser warm-up failure Fuser type = 1	The fuser hot roll fell to far below desired temperature while in standby control.	<ol style="list-style-type: none"> <li>1. Turn the machine off/on and ensure the fuser unit assembly is properly installed.</li> <li>2. Ensure the proper voltage fuser is installed in the machine.</li> <li>3. Replace the fuser unit assembly if problem remains. Go to <b>“Fuser unit assembly removal (T650, T652, T654)” on page 4-23.</b></li> </ol>

Error code or message	Error contents	Description/Action	Possible repair actions
920.03	Fuser warm-up failure Fuser type = 1	The fuser hot roll is too cool while checking for slope change in standby.	<ol style="list-style-type: none"> <li>1. Turn the machine off/on and ensure the fuser unit assembly is properly installed.</li> <li>2. Ensure the proper voltage fuser is installed in the machine.</li> <li>3. Replace the fuser unit assembly if problem remains. Go to <b>“Fuser unit assembly removal (T650, T652, T654)” on page 4-23.</b></li> </ol>
920.04	Fuser warm-up failure Fuser type = 1	The fuser hot roll is too cool when heating to desired temperature after slope change within standby control only.	<ol style="list-style-type: none"> <li>1. Turn the machine off/on and ensure the fuser unit assembly is properly installed.</li> <li>2. Ensure the proper voltage fuser is installed in the machine.</li> <li>3. Replace the fuser unit assembly if problem remains. Go to <b>“Fuser unit assembly removal (T650, T652, T654)” on page 4-23.</b></li> </ol>
920.06	Fuser warm-up failure Fuser type = 1	The fuser hot roll temperature does not increase while the lamp is turned on.	<ol style="list-style-type: none"> <li>1. Turn the machine off/on and ensure the fuser unit assembly is properly installed.</li> <li>2. Ensure the proper voltage fuser is installed in the machine.</li> <li>3. Check all connections on the fuser and LVPS card assembly.</li> <li>4. Ensure the proper voltage setting is being used on the switchable LVPS assembly.</li> <li>5. Replace the fuser unit assembly if problem remains. Go to <b>“Fuser unit assembly removal (T650, T652, T654)” on page 4-23.</b></li> <li>6. Replace the LVPS card assembly if problem remains. Go to <b>“System card assembly removal (T650, T652, T654, T656)” on page 4-76 or “LVPS card assembly removal (T652, T654)” on page 4-31.</b></li> </ol>

Error code or message	Error contents	Description/Action	Possible repair actions
920.07	Fuser warm-up failure Fuser type = 1	The fuser hot roll temperature is not maintained properly while the media in the fuser nip.	<ol style="list-style-type: none"> <li>1. Turn the machine off/on and ensure the fuser unit assembly is properly installed.</li> <li>2. Ensure the proper voltage fuser is installed in the machine.</li> <li>3. Check all connections on the fuser and LVPS card assembly.</li> <li>4. Replace the fuser unit assembly if problem remains. Go to <b>“Fuser unit assembly removal (T650, T652, T654)” on page 4-23.</b></li> <li>5. Replace the LVPS card assembly if problem remains. Go to <b>“System card assembly removal (T650, T652, T654, T656)” on page 4-76</b> or <b>“LVPS card assembly removal (T652, T654)” on page 4-31.</b></li> </ol>
920.25	Fuser under temperature Fuser type = 2	Fuser does not maintain proper operating temperature within steady state control.	<ol style="list-style-type: none"> <li>1. Turn the machine off/on and ensure the fuser unit assembly is properly installed.</li> <li>2. Ensure the proper voltage fuser is installed in the machine.</li> <li>3. Replace the fuser unit assembly if problem remains. Go to <b>“Fuser unit assembly removal (T650, T652, T654)” on page 4-23.</b></li> </ol>
920.26	Fuser warm-up failure Fuser type = 2	The fuser hot roll took too long to heat up after transitioning to new enhanced mode within standby control only.	<ol style="list-style-type: none"> <li>1. Turn the machine off/on and ensure the fuser unit assembly is properly installed.</li> <li>2. Ensure the proper voltage fuser is installed in the machine.</li> <li>3. Replace the fuser unit assembly if problem remains. Go to <b>“Fuser unit assembly removal (T650, T652, T654)” on page 4-23.</b></li> </ol>

Error code or message	Error contents	Description/Action	Possible repair actions
920.27	Fuser warm-up failure Fuser type = 2	The fuser hot roll fell to far below desired temperature while in standby control.	<ol style="list-style-type: none"> <li>1. Turn the machine off/on and ensure the fuser unit assembly is properly installed.</li> <li>2. Ensure the proper voltage fuser is installed in the machine.</li> <li>3. Replace the fuser unit assembly if problem remains. Go to <b>“Fuser unit assembly removal (T650, T652, T654)” on page 4-23.</b></li> </ol>
920.28	Fuser warm-up failure Fuser type = 2	The fuser hot roll is too cool while checking for slope change in standby.	<ol style="list-style-type: none"> <li>1. Turn the machine off/on and ensure the fuser unit assembly is properly installed.</li> <li>2. Ensure the proper voltage fuser is installed in the machine.</li> <li>3. Replace the fuser unit assembly if problem remains. Go to <b>“Fuser unit assembly removal (T650, T652, T654)” on page 4-23.</b></li> </ol>
920.29	Fuser warm-up failure Fuser type = 2	The fuser hot roll is too cool when heating to desired temperature after slope change within standby control only.	<ol style="list-style-type: none"> <li>1. Turn the machine off/on and ensure the fuser unit assembly is properly installed.</li> <li>2. Ensure the proper voltage fuser is installed in the machine.</li> <li>3. Replace the fuser unit assembly if problem remains. Go to <b>“Fuser unit assembly removal (T650, T652, T654)” on page 4-23.</b></li> </ol>



Error code or message	Error contents	Description/Action	Possible repair actions
920.31	Fuser warm-up failure Fuser type = 2	The fuser hot roll temperature does not increase while the lamp is turned on.	<ol style="list-style-type: none"> <li>1. Turn the machine off/on and ensure the fuser unit assembly is properly installed.</li> <li>2. Ensure the proper voltage fuser is installed in the machine.</li> <li>3. Check all connections on the fuser and LVPS card assembly.</li> <li>4. Replace the fuser unit assembly if problem remains. Go to <b>“Fuser unit assembly removal (T650, T652, T654)” on page 4-23.</b></li> <li>5. Replace the LVPS card assembly if problem remains. Go to <b>“System card assembly removal (T650, T652, T654, T656)” on page 4-76</b> or <b>“LVPS card assembly removal (T652, T654)” on page 4-31.</b></li> </ol>
920.32	Fuser warm-up failure Fuser type = 2	The fuser hot roll temperature is not maintained properly while the media in the fuser nip.	<ol style="list-style-type: none"> <li>1. Turn the machine off/on and ensure the fuser unit assembly is properly installed.</li> <li>2. Ensure the proper voltage fuser is installed in the machine.</li> <li>3. Check all connections on the fuser and LVPS card assembly.</li> <li>4. Replace the fuser unit assembly if problem remains. Go to <b>“Fuser unit assembly removal (T650, T652, T654)” on page 4-23.</b></li> <li>5. Replace the LVPS card assembly if problem remains. Go to <b>“System card assembly removal (T650, T652, T654, T656)” on page 4-76</b> or <b>“LVPS card assembly removal (T652, T654)” on page 4-31.</b></li> </ol>
920.50	Fuser under temperature Fuser type = 1 Fuser page count has exceeded life.	Fuser does not maintain proper operating temperature within steady state control.	Replace the fuser unit assembly if problem remains. Go to <b>“Fuser unit assembly removal (T650, T652, T654)” on page 4-23.</b>
920.51	Fuser warm-up failure Fuser type = 1 Fuser page count has exceeded life.	The fuser hot roll took too long to heat up after transitioning to new enhanced mode within standby control only.	Replace the fuser unit assembly if problem remains. Go to <b>“Fuser unit assembly removal (T650, T652, T654)” on page 4-23.</b>

<b>Error code or message</b>	<b>Error contents</b>	<b>Description/Action</b>	<b>Possible repair actions</b>
920.52	Fuser warm-up failure Fuser type = 1 Fuser page count has exceeded life.	The fuser hot roll fell to far below desired temperature while in standby control.	Replace the fuser unit assembly if problem remains. Go to <b>“Fuser unit assembly removal (T650, T652, T654)” on page 4-23.</b>
920.53	Fuser warm-up failure Fuser type = 1 Fuser page count has exceeded life.	The fuser hot roll is too cool while checking for slope change in standby.	Replace the fuser unit assembly if problem remains. Go to <b>“Fuser unit assembly removal (T650, T652, T654)” on page 4-23.</b>
920.54	Fuser warm-up failure Fuser type = 1 Fuser page count has exceeded life.	The fuser hot roll is too cool when heating to desired temperature after slope change within standby control only.	Replace the fuser unit assembly if problem remains. Go to <b>“Fuser unit assembly removal (T650, T652, T654)” on page 4-23.</b>
920.56	Fuser warm-up failure Fuser type = 1 Fuser page count has exceeded life.	The fuser hot roll temperature does not increase while the lamp is turned on.	Replace the fuser unit assembly if problem remains. Go to <b>“Fuser unit assembly removal (T650, T652, T654)” on page 4-23.</b>
920.57	Fuser warm-up failure Fuser type = 1 Fuser page count has exceeded life.	The fuser hot roll temperature is not maintained properly while the media in the fuser nip.	Replace the fuser unit assembly if problem remains. Go to <b>“Fuser unit assembly removal (T650, T652, T654)” on page 4-23.</b>
920.75	Fuser under temperature Fuser type = 2 Fuser page count has exceeded life.	Fuser does not maintain proper operating temperature within steady state control.	Replace the fuser unit assembly if problem remains. Go to <b>“Fuser unit assembly removal (T650, T652, T654)” on page 4-23.</b>
920.76	Fuser warm-up failure Fuser type = 2 Fuser page count has exceeded life.	The fuser hot roll took too long to heat up after transitioning to new enhanced mode within standby control only.	Replace the fuser unit assembly if problem remains. Go to <b>“Fuser unit assembly removal (T650, T652, T654)” on page 4-23.</b>
920.77	Fuser warm-up failure Fuser type = 2 Fuser page count has exceeded life.	The fuser hot roll fell to far below desired temperature while in standby control.	Replace the fuser unit assembly if problem remains. Go to <b>“Fuser unit assembly removal (T650, T652, T654)” on page 4-23.</b>
920.78	Fuser warm-up failure Fuser type = 2 Fuser page count has exceeded life.	The fuser hot roll is too cool while checking for slope change in standby.	Replace the fuser unit assembly if problem remains. Go to <b>“Fuser unit assembly removal (T650, T652, T654)” on page 4-23.</b>
920.79	Fuser warm-up failure Fuser type = 2 Fuser page count has exceeded life.	The fuser hot roll is too cool when heating to desired temperature after slope change within standby control only.	Replace the fuser unit assembly if problem remains. Go to <b>“Fuser unit assembly removal (T650, T652, T654)” on page 4-23.</b>

Error code or message	Error contents	Description/Action	Possible repair actions
920.81	Fuser warm-up failure Fuser type = 2 Fuser page count has exceeded life.	The fuser hot roll temperature does not increase while the lamp is turned on.	Replace the fuser unit assembly if problem remains. Go to <b>“Fuser unit assembly removal (T650, T652, T654)” on page 4-23.</b>
920.82	Fuser warm-up failure Fuser type = 2 Fuser page count has exceeded life.	The fuser hot roll temperature is not maintained properly while the media in the fuser nip.	Replace the fuser unit assembly if problem remains. Go to <b>“Fuser unit assembly removal (T650, T652, T654)” on page 4-23.</b>
922.00	Fuser warm-up failure Fuser type = 1	The fuser hot roll failed to reach target departure.	<ol style="list-style-type: none"> <li>1. Turn the machine off/on and ensure the fuser unit assembly is properly installed.</li> <li>2. Ensure the proper voltage fuser is installed in the machine.</li> <li>3. Replace the fuser unit assembly if problem remains. Go to <b>“Fuser unit assembly removal (T650, T652, T654)” on page 4-23.</b></li> </ol>
922.02	Fuser warm-up failure Fuser type = 1	The fuser hot roll does not reach the “beginning lamp detection” parameter in the specified time.	<ol style="list-style-type: none"> <li>1. Turn the machine off/on and ensure the fuser unit assembly is properly installed.</li> <li>2. Ensure the proper voltage fuser is installed in the machine.</li> <li>3. Check all connections on the fuser and LVPS card assembly.</li> <li>4. Replace the fuser unit assembly if problem remains. Go to <b>“Fuser unit assembly removal (T650, T652, T654)” on page 4-23.</b></li> <li>5. Replace the LVPS card assembly if problem remains. Go to <b>“System card assembly removal (T650, T652, T654, T656)” on page 4-76</b> or <b>“LVPS card assembly removal (T652, T654)” on page 4-31.</b></li> </ol>

Error code or message	Error contents	Description/Action	Possible repair actions
922.03	Fuser warm-up failure Fuser type = 1	The fuser hot roll does reach the "final lamp detection" parameter but not in the specified time.	<ol style="list-style-type: none"> <li>1. Turn the machine off/on and ensure the fuser unit assembly is properly installed.</li> <li>2. Ensure the proper voltage fuser is installed in the machine.</li> <li>3. Check all connections on the fuser and LVPS card assembly.</li> <li>4. Replace the fuser unit assembly if problem remains. Go to <b>"Fuser unit assembly removal (T650, T652, T654)" on page 4-23.</b></li> <li>5. Replace the LVPS card assembly if problem remains. Go to <b>"System card assembly removal (T650, T652, T654, T656)" on page 4-76</b> or <b>"LVPS card assembly removal (T652, T654)" on page 4-31.</b></li> </ol>
922.04	Fuser warm-up failure Fuser type = 1	The fuser hot roll has timed out and not reached "final lamp detection" during the specified time.	<ol style="list-style-type: none"> <li>1. Turn the machine off/on and ensure the fuser unit assembly is properly installed.</li> <li>2. Ensure the proper voltage fuser is installed in the machine.</li> <li>3. Check all connections on the fuser and LVPS card assembly.</li> <li>4. Replace the fuser unit assembly if problem remains. Go to <b>"Fuser unit assembly removal (T650, T652, T654)" on page 4-23.</b></li> <li>5. Replace the LVPS card assembly if problem remains. Go to <b>"System card assembly removal (T650, T652, T654, T656)" on page 4-76</b> or <b>"LVPS card assembly removal (T652, T654)" on page 4-31.</b></li> </ol>
922.05	After hot roll lamp detection, did not roll over to steady state control in time. Fuser type = 1	The control code has gotten lost (this should really be a software error).	Turn the machine off/on.

Error code or message	Error contents	Description/Action	Possible repair actions
922.06	Fuser warm-up failure Fuser type = 1	The fuser hot roll did not reach operating temperature within new enhanced control.	<ol style="list-style-type: none"> <li>1. Turn the machine off/on and ensure the fuser unit assembly is properly installed.</li> <li>2. Ensure the proper voltage fuser is installed in the machine.</li> <li>3. Check all connections on the fuser and LVPS card assembly.</li> <li>4. Replace the fuser unit assembly if problem remains. Go to <b>“Fuser unit assembly removal (T650, T652, T654)” on page 4-23.</b></li> <li>5. Replace the LVPS card assembly if problem remains. Go to <b>“System card assembly removal (T650, T652, T654, T656)” on page 4-76</b> or <b>“LVPS card assembly removal (T652, T654)” on page 4-31.</b></li> </ol>
922.07	Fuser warm-up failure Fuser type = 1	The fuser hot roll does not reach operating temperature after increasing interpage gap.	<ol style="list-style-type: none"> <li>1. Turn the machine off/on and ensure the fuser unit assembly is properly installed.</li> <li>2. Ensure the proper voltage fuser is installed in the machine.</li> <li>3. Check all connections on the fuser and LVPS card assembly.</li> <li>4. Replace the fuser unit assembly if problem remains. Go to <b>“Fuser unit assembly removal (T650, T652, T654)” on page 4-23.</b></li> <li>5. Replace the LVPS card assembly if problem remains. Go to <b>“System card assembly removal (T650, T652, T654, T656)” on page 4-76</b> or <b>“LVPS card assembly removal (T652, T654)” on page 4-31.</b></li> </ol>

Error code or message	Error contents	Description/Action	Possible repair actions
922.25	Fuser warm-up failure Fuser type = 2	The fuser hot roll failed to reach target departure.	<ol style="list-style-type: none"> <li>1. Turn the machine off/on and ensure the fuser unit assembly is properly installed.</li> <li>2. Ensure the proper voltage fuser is installed in the machine.</li> <li>3. Replace the fuser unit assembly if problem remains. Go to <b>“Fuser unit assembly removal (T650, T652, T654)” on page 4-23.</b></li> </ol>
922.27	Fuser warm-up failure Fuser type = 2	The fuser hot roll does not reach the “beginning lamp detection” parameter in the specified time.	<ol style="list-style-type: none"> <li>1. Turn the machine off/on and ensure the fuser unit assembly is properly installed.</li> <li>2. Ensure the proper voltage fuser is installed in the machine.</li> <li>3. Check all connections on the fuser and LVPS card assembly.</li> <li>4. Replace the fuser unit assembly if problem remains. Go to <b>“Fuser unit assembly removal (T650, T652, T654)” on page 4-23.</b></li> <li>5. Replace the LVPS card assembly if problem remains. Go to <b>“System card assembly removal (T650, T652, T654, T656)” on page 4-76</b> or <b>“LVPS card assembly removal (T652, T654)” on page 4-31.</b></li> </ol>

Error code or message	Error contents	Description/Action	Possible repair actions
922.28	Fuser warm-up failure Fuser type = 2	The fuser hot roll does reach the "final lamp detection" parameter but not in the specified time.	<ol style="list-style-type: none"> <li>1. Turn the machine off/on and ensure the fuser unit assembly is properly installed.</li> <li>2. Ensure the proper voltage fuser is installed in the machine.</li> <li>3. Check all connections on the fuser and LVPS card assembly.</li> <li>4. Replace the fuser unit assembly if problem remains. Go to <b>"Fuser unit assembly removal (T650, T652, T654)" on page 4-23.</b></li> <li>5. Replace the LVPS card assembly if problem remains. Go to <b>"System card assembly removal (T650, T652, T654, T656)" on page 4-76</b> or <b>"LVPS card assembly removal (T652, T654)" on page 4-31.</b></li> </ol>
922.29	Fuser warm-up failure Fuser type = 2	The fuser hot roll has timed out and not reached "final lamp detection" during the specified time.	<ol style="list-style-type: none"> <li>1. Turn the machine off/on and ensure the fuser unit assembly is properly installed.</li> <li>2. Ensure the proper voltage fuser is installed in the machine.</li> <li>3. Check all connections on the fuser and LVPS card assembly.</li> <li>4. Replace the fuser unit assembly if problem remains. Go to <b>"Fuser unit assembly removal (T650, T652, T654)" on page 4-23.</b></li> <li>5. Replace the LVPS card assembly if problem remains. Go to <b>"System card assembly removal (T650, T652, T654, T656)" on page 4-76</b> or <b>"LVPS card assembly removal (T652, T654)" on page 4-31.</b></li> </ol>
922.30	After hot roll lamp detection, did not roll over to steady state control in time. Fuser type = 2	The control code has gotten lost (this should really be a software error.	Turn the machine off/on.

Error code or message	Error contents	Description/Action	Possible repair actions
922.31	Fuser warm-up failure Fuser type = 2	The fuser hot roll did not reach operating temperature within new enhanced control.	<ol style="list-style-type: none"> <li>1. Turn the machine off/on and ensure the fuser unit assembly is properly installed.</li> <li>2. Ensure the proper voltage fuser is installed in the machine.</li> <li>3. Check all connections on the fuser and LVPS card assembly.</li> <li>4. Replace the fuser unit assembly if problem remains. Go to <b>“Fuser unit assembly removal (T650, T652, T654)” on page 4-23.</b></li> <li>5. Replace the LVPS card assembly if problem remains. Go to <b>“System card assembly removal (T650, T652, T654, T656)” on page 4-76</b> or <b>“LVPS card assembly removal (T652, T654)” on page 4-31.</b></li> </ol>
922.32	Fuser warm-up failure Fuser type = 2	The fuser hot roll does not reach operating temperature after increasing interpage gap.	<ol style="list-style-type: none"> <li>1. Turn the machine off/on and ensure the fuser unit assembly is properly installed.</li> <li>2. Ensure the proper voltage fuser is installed in the machine.</li> <li>3. Check all connections on the fuser and LVPS card assembly.</li> <li>4. Replace the fuser unit assembly if problem remains. Go to <b>“Fuser unit assembly removal (T650, T652, T654)” on page 4-23.</b></li> <li>5. Replace the LVPS card assembly if problem remains. Go to <b>“System card assembly removal (T650, T652, T654, T656)” on page 4-76</b> or <b>“LVPS card assembly removal (T652, T654)” on page 4-31.</b></li> </ol>
922.50	Fuser warm-up failure Fuser type = 1 Fuser page count has exceeded life.	The fuser hot roll failed to reach target temperature.	Replace the fuser unit assembly if problem remains. Go to <b>“Fuser unit assembly removal (T650, T652, T654)” on page 4-23.</b>
922.52	Fuser warm-up failure Fuser type = 1 Fuser page count has exceeded life.	The fuser hot roll does not reach the “beginning lamp detection” parameter in the specified time.	Replace the fuser unit assembly if problem remains. Go to <b>“Fuser unit assembly removal (T650, T652, T654)” on page 4-23.</b>



Error code or message	Error contents	Description/Action	Possible repair actions
922.53	Fuser warm-up failure Fuser type = 1 Fuser page count has exceeded life.	The fuser hot roll does not reach the "final lamp detection" parameter but not in the specified time.	Replace the fuser unit assembly if problem remains. Go to <b>"Fuser unit assembly removal (T650, T652, T654)" on page 4-23.</b>
922.54	Fuser warm-up failure Fuser type = 1 Fuser page count has exceeded life.	The fuser hot roll has timed out and not reached "final lamp detection" during the specified time.	Replace the fuser unit assembly if problem remains. Go to <b>"Fuser unit assembly removal (T650, T652, T654)" on page 4-23.</b>
922.56	Fuser warm-up failure Fuser type = 1 Fuser page count has exceeded life.	The fuser hot roll did not reach operating temperature within new enhanced control.	Replace the fuser unit assembly if problem remains. Go to <b>"Fuser unit assembly removal (T650, T652, T654)" on page 4-23.</b>
922.57	Fuser warm-up failure Fuser type = 1 Fuser page count has exceeded life.	The fuser hot roll does not reach operating temperature after increasing interpage gap.	Replace the fuser unit assembly if problem remains. Go to <b>"Fuser unit assembly removal (T650, T652, T654)" on page 4-23.</b>
922.75	Fuser warm-up failure Fuser type = 2 Fuser page count has exceeded life.	The fuser hot roll failed to reach target temperature.	Replace the fuser unit assembly if problem remains. Go to <b>"Fuser unit assembly removal (T650, T652, T654)" on page 4-23.</b>
922.77	Fuser warm-up failure Fuser type = 2 Fuser page count has exceeded life.	The fuser hot roll does not reach the "beginning lamp detection" parameter in the specified time.	Replace the fuser unit assembly if problem remains. Go to <b>"Fuser unit assembly removal (T650, T652, T654)" on page 4-23.</b>
922.78	Fuser warm-up failure Fuser type = 2 Fuser page count has exceeded life.	The fuser hot roll does not reach the "final lamp detection" parameter but not in the specified time.	Replace the fuser unit assembly if problem remains. Go to <b>"Fuser unit assembly removal (T650, T652, T654)" on page 4-23.</b>
922.79	Fuser warm-up failure Fuser type = 2 Fuser page count has exceeded life.	The fuser hot roll has timed out and not reached "final lamp detection" during the specified time.	Replace the fuser unit assembly if problem remains. Go to <b>"Fuser unit assembly removal (T650, T652, T654)" on page 4-23.</b>
922.81	Fuser warm-up failure Fuser type = 2 Fuser page count has exceeded life.	The fuser hot roll did not reach operating temperature within new enhanced control.	Replace the fuser unit assembly if problem remains. Go to <b>"Fuser unit assembly removal (T650, T652, T654)" on page 4-23.</b>
922.82	Fuser warm-up failure Fuser type = 2 Fuser page count has exceeded life.	The fuser hot roll does not reach operating temperature after increasing interpage gap.	Replace the fuser unit assembly if problem remains. Go to <b>"Fuser unit assembly removal (T650, T652, T654)" on page 4-23.</b>

Error code or message	Error contents	Description/Action	Possible repair actions
923.00	Fuser over temperature failure. Fuser type = 1	The fuser hot roll has exceeded the proper operating temperature.	<ol style="list-style-type: none"> <li>1. Turn the machine off/on and ensure the fuser unit assembly is properly installed.</li> <li>2. Ensure the proper voltage fuser is installed in the machine.</li> <li>3. Replace the fuser unit assembly if problem remains. Go to <b>“Fuser unit assembly removal (T650, T652, T654)” on page 4-23.</b></li> </ol>
923.01	Fuser over temperature failure. Fuser type = 1	The fuser hot roll has exceeded the proper operating temperature.	<ol style="list-style-type: none"> <li>1. Turn the machine off/on and ensure the fuser unit assembly is properly installed.</li> <li>2. Ensure the proper voltage fuser is installed in the machine.</li> <li>3. Replace the fuser unit assembly if problem remains. Go to <b>“Fuser unit assembly removal (T650, T652, T654)” on page 4-23.</b></li> </ol>
923.25	Fuser over temperature failure. Fuser type = 2	The fuser hot roll has exceeded the proper operating temperature.	<ol style="list-style-type: none"> <li>1. Turn the machine off/on and ensure the fuser unit assembly is properly installed.</li> <li>2. Ensure the proper voltage fuser is installed in the machine.</li> <li>3. Replace the fuser unit assembly if problem remains. Go to <b>“Fuser unit assembly removal (T650, T652, T654)” on page 4-23.</b></li> </ol>
923.26	Fuser over temperature failure. Fuser type = 2	The fuser hot roll has exceeded the proper operating temperature.	<ol style="list-style-type: none"> <li>1. Turn the machine off/on and ensure the fuser unit assembly is properly installed.</li> <li>2. Ensure the proper voltage fuser is installed in the machine.</li> <li>3. Replace the fuser unit assembly if problem remains. Go to <b>“Fuser unit assembly removal (T650, T652, T654)” on page 4-23.</b></li> </ol>
923.50	Fuser over temperature failure. Fuser type = 1	The fuser hot roll has exceeded the proper operating temperature.	Replace the fuser unit assembly if problem remains. Go to <b>“Fuser unit assembly removal (T650, T652, T654)” on page 4-23.</b>

<b>Error code or message</b>	<b>Error contents</b>	<b>Description/Action</b>	<b>Possible repair actions</b>
923.51	Fuser over temperature failure. Fuser type = 1	The fuser hot roll has exceeded the proper operating temperature.	Replace the fuser unit assembly if problem remains. Go to <b>"Fuser unit assembly removal (T650, T652, T654)" on page 4-23.</b>
923.75	Fuser over temperature failure. Fuser type = 2	The fuser hot roll has exceeded the proper operating temperature.	Replace the fuser unit assembly if problem remains. Go to <b>"Fuser unit assembly removal (T650, T652, T654)" on page 4-23.</b>
923.76	Fuser over temperature failure. Fuser type = 2	The fuser hot roll has exceeded the proper operating temperature.	Replace the fuser unit assembly if problem remains. Go to <b>"Fuser unit assembly removal (T650, T652, T654)" on page 4-23.</b>
924.00	Open fuser thermistor check Fuser type = 1	The fuser thermistor might be faulty.	Replace the fuser unit assembly if problem remains. Go to <b>"Fuser unit assembly removal (T650, T652, T654)" on page 4-23.</b>
924.01	Open fuser thermistor check failure. Fuser type = 1	The fuser thermistor has failed.	Replace the fuser unit assembly if problem remains. Go to <b>"Fuser unit assembly removal (T650, T652, T654)" on page 4-23.</b>
924.25	Open fuser thermistor check Fuser type = 2	The fuser thermistor might be faulty.	Replace the fuser unit assembly if problem remains. Go to <b>"Fuser unit assembly removal (T650, T652, T654)" on page 4-23.</b>
924.26	Open fuser thermistor check failure. Fuser type = 2	The fuser thermistor has failed.	Replace the fuser unit assembly if problem remains. Go to <b>"Fuser unit assembly removal (T650, T652, T654)" on page 4-23.</b>
924.50	Open fuser thermistor check Fuser type = 1 Fuser page count has exceeded life.	The fuser thermistor might be faulty.	Replace the fuser unit assembly if problem remains. Go to <b>"Fuser unit assembly removal (T650, T652, T654)" on page 4-23.</b>
924.51	Open fuser thermistor check failure. Fuser type = 1 Fuser page count has exceeded life.	The fuser thermistor has failed.	Replace the fuser unit assembly if problem remains. Go to <b>"Fuser unit assembly removal (T650, T652, T654)" on page 4-23.</b>
924.75	Open fuser thermistor check Fuser type = 2 Fuser page count has exceeded life.	The fuser thermistor might be faulty.	Replace the fuser unit assembly if problem remains. Go to <b>"Fuser unit assembly removal (T650, T652, T654)" on page 4-23.</b>

Error code or message	Error contents	Description/Action	Possible repair actions
924.76	Open fuser thermistor check failure. Fuser type = 2 Fuser page count has exceeded life.	The fuser thermistor has failed.	Replace the fuser unit assembly if problem remains. Go to <b>“Fuser unit assembly removal (T650, T652, T654)” on page 4-23.</b>
925.00	Incorrect fuser or fuser lamp detected. Fuser type = 1	The machine detected a 115 V lamp in a 220 V machine. The fuser lamp has an excessive wattage rating.	<ol style="list-style-type: none"> <li>1. Turn the machine off/on and ensure the fuser unit assembly is properly installed.</li> <li>2. Ensure the proper voltage fuser is installed in the machine.</li> <li>3. Replace the fuser unit assembly if problem remains. Go to <b>“Fuser unit assembly removal (T650, T652, T654)” on page 4-23.</b></li> </ol>
925.01	Incorrect fuser or fuser lamp detected. Fuser type = 1	The machine detected a 115 V lamp in a 220 V machine. The fuser lamp has an excessive wattage rating.	<ol style="list-style-type: none"> <li>1. Turn the machine off/on and ensure the fuser unit assembly is properly installed.</li> <li>2. Ensure the proper voltage fuser is installed in the machine.</li> <li>3. Replace the fuser unit assembly if problem remains. Go to <b>“Fuser unit assembly removal (T650, T652, T654)” on page 4-23.</b></li> </ol>
925.02	Incorrect fuser or fuser lamp detected. Fuser type = 1	The machine detected a 115 V lamp in a 220 V machine. The fuser lamp has an excessive wattage rating.	<ol style="list-style-type: none"> <li>1. Turn the machine off/on and ensure the fuser unit assembly is properly installed.</li> <li>2. Ensure the proper voltage fuser is installed in the machine.</li> <li>3. Replace the fuser unit assembly if problem remains. Go to <b>“Fuser unit assembly removal (T650, T652, T654)” on page 4-23.</b></li> </ol>
925.25	Incorrect fuser or fuser lamp detected. Fuser type = 2	The machine detected a 115 V lamp in a 220 V machine. The fuser lamp has an excessive wattage rating.	<ol style="list-style-type: none"> <li>1. Turn the machine off/on and ensure the fuser unit assembly is properly installed.</li> <li>2. Ensure the proper voltage fuser is installed in the machine.</li> <li>3. Replace the fuser unit assembly if problem remains. Go to <b>“Fuser unit assembly removal (T650, T652, T654)” on page 4-23.</b></li> </ol>

Error code or message	Error contents	Description/Action	Possible repair actions
925.26	Incorrect fuser or fuser lamp detected. Fuser type = 2	The machine detected a 115 V lamp in a 220 V machine. The fuser lamp has an excessive wattage rating.	<ol style="list-style-type: none"> <li>1. Turn the machine off/on and ensure the fuser unit assembly is properly installed.</li> <li>2. Ensure the proper voltage fuser is installed in the machine.</li> <li>3. Replace the fuser unit assembly if problem remains. Go to <b>“Fuser unit assembly removal (T650, T652, T654)” on page 4-23.</b></li> </ol>
925.27	Incorrect fuser or fuser lamp detected. Fuser type = 2	The machine detected a 115 V lamp in a 220 V machine. The fuser lamp has an excessive wattage rating.	<ol style="list-style-type: none"> <li>1. Turn the machine off/on and ensure the fuser unit assembly is properly installed.</li> <li>2. Ensure the proper voltage fuser is installed in the machine.</li> <li>3. Replace the fuser unit assembly if problem remains. Go to <b>“Fuser unit assembly removal (T650, T652, T654)” on page 4-23.</b></li> </ol>
925.50	Incorrect fuser or fuser lamp detected. Fuser type = 1 Fuser page count has exceeded life.	The machine detected a 115 V lamp in a 220 V machine. The fuser lamp has an excessive wattage rating.	<ol style="list-style-type: none"> <li>1. Turn the machine off/on and ensure the fuser unit assembly is properly installed.</li> <li>2. Ensure the proper voltage fuser is installed in the machine.</li> <li>3. Replace the fuser unit assembly if problem remains. Go to <b>“Fuser unit assembly removal (T650, T652, T654)” on page 4-23.</b></li> </ol>
925.51	Incorrect fuser or fuser lamp detected. Fuser type = 1 Fuser page count has exceeded life.	The machine detected a 115 V lamp in a 220 V machine. The fuser lamp has an excessive wattage rating.	<ol style="list-style-type: none"> <li>1. Turn the machine off/on and ensure the fuser unit assembly is properly installed.</li> <li>2. Ensure the proper voltage fuser is installed in the machine.</li> <li>3. Replace the fuser unit assembly if problem remains. Go to <b>“Fuser unit assembly removal (T650, T652, T654)” on page 4-23.</b></li> </ol>

Error code or message	Error contents	Description/Action	Possible repair actions
925.52	Incorrect fuser or fuser lamp detected. Fuser type = 1 Fuser page count has exceeded life.	The machine detected a 115 V lamp in a 220 V machine. The fuser lamp has an excessive wattage rating.	<ol style="list-style-type: none"> <li>1. Turn the machine off/on and ensure the fuser unit assembly is properly installed.</li> <li>2. Ensure the proper voltage fuser is installed in the machine.</li> <li>3. Replace the fuser unit assembly if problem remains. Go to <b>“Fuser unit assembly removal (T650, T652, T654)” on page 4-23.</b></li> </ol>
925.75	Incorrect fuser or fuser lamp detected. Fuser type = 2 Fuser page count has exceeded life.	The machine detected a 115 V lamp in a 220 V machine. The fuser lamp has an excessive wattage rating.	<ol style="list-style-type: none"> <li>1. Turn the machine off/on and ensure the fuser unit assembly is properly installed.</li> <li>2. Ensure the proper voltage fuser is installed in the machine.</li> <li>3. Replace the fuser unit assembly if problem remains. Go to <b>“Fuser unit assembly removal (T650, T652, T654)” on page 4-23.</b></li> </ol>
925.76	Incorrect fuser or fuser lamp detected. Fuser type = 2 Fuser page count has exceeded life.	The machine detected a 115 V lamp in a 220 V machine. The fuser lamp has an excessive wattage rating.	<ol style="list-style-type: none"> <li>1. Turn the machine off/on and ensure the fuser unit assembly is properly installed.</li> <li>2. Ensure the proper voltage fuser is installed in the machine.</li> <li>3. Replace the fuser unit assembly if problem remains. Go to <b>“Fuser unit assembly removal (T650, T652, T654)” on page 4-23.</b></li> </ol>
925.77	Incorrect fuser or fuser lamp detected. Fuser type = 2 Fuser page count has exceeded life.	The machine detected a 115 V lamp in a 220 V machine. The fuser lamp has an excessive wattage rating.	<ol style="list-style-type: none"> <li>1. Turn the machine off/on and ensure the fuser unit assembly is properly installed.</li> <li>2. Ensure the proper voltage fuser is installed in the machine.</li> <li>3. Replace the fuser unit assembly if problem remains. Go to <b>“Fuser unit assembly removal (T650, T652, T654)” on page 4-23.</b></li> </ol>

Error code or message	Error contents	Description/Action	Possible repair actions
927.01	Main cooling fan failure.	The cooling fan is obstructed or has failed.	<ol style="list-style-type: none"> <li>1. Check for cooling fan obstructions.</li> <li>2. Check the connections on the main cooling fan.</li> <li>3. Replace the main cooling fan. Go to <b>“Output cover assembly removal (T650, T652, T654)” on page 4-54.</b></li> </ol>
927.02	Print cartridge cooling fan failure.	The cooling fan is obstructed or has failed.	<ol style="list-style-type: none"> <li>1. Check for cooling fan obstructions.</li> <li>2. Check the connections on the main cooling fan.</li> <li>3. Replace the print cartridge cooling fan. Go to <b>“Print cartridge cooling fan removal (T650, T652, T654)” on page 4-57.</b></li> </ol>
927.03	Main cooling fan control failure.	The main cooling fan does not reach the specified speed.	<ol style="list-style-type: none"> <li>4. Check for cooling fan obstructions.</li> <li>5. Check the connections on the main cooling fan.</li> <li>6. Replace the main cooling fan. Go to <b>“Output cover assembly removal (T650, T652, T654)” on page 4-54.</b></li> </ol>
927.04	Main cooling fan under speed failure	The main cooling fan does not reach the specified speed.	<ol style="list-style-type: none"> <li>1. Check for cooling fan obstructions.</li> <li>2. Check the connections on the main cooling fan.</li> <li>3. Replace the main cooling fan. Go to <b>“Output cover assembly removal (T650, T652, T654)” on page 4-54.</b></li> </ol>
927.05	Main cooling fan over speed failure.	The main cooling fan does not reach the specified speed.	<ol style="list-style-type: none"> <li>1. Check for cooling fan obstructions.</li> <li>2. Check the connections on the main cooling fan.</li> <li>3. Replace the main cooling fan. Go to <b>“Output cover assembly removal (T650, T652, T654)” on page 4-54.</b></li> </ol>
927.06	Main cooling fan over speed failure.	The main cooling fan does not reach the specified speed.	<ol style="list-style-type: none"> <li>1. Check for cooling fan obstructions.</li> <li>2. Check the connections on the main cooling fan.</li> <li>3. Replace the main cooling fan. Go to <b>“Output cover assembly removal (T650, T652, T654)” on page 4-54.</b></li> </ol>

Error code or message	Error contents	Description/Action	Possible repair actions
927.07	Main cooling fan over speed failure.	The main cooling fan does not reach the specified speed.	<ol style="list-style-type: none"> <li>1. Check for cooling fan obstructions.</li> <li>2. Check the connections on the main cooling fan.</li> <li>3. Replace the main cooling fan. Go to <b>“Output cover assembly removal (T650, T652, T654)” on page 4-54.</b></li> </ol>
927.11	Print cartridge cooling fan failure	The print cartridge cooling fan is obstructed or has failed.	<ol style="list-style-type: none"> <li>1. Check for cooling fan obstructions.</li> <li>2. Check the connections on the main cooling fan.</li> <li>3. Replace the print cartridge cooling fan. Go to <b>“Print cartridge cooling fan removal (T650, T652, T654)” on page 4-57.</b></li> </ol>
927.13	Print cartridge cooling fan control failure.	The Print cartridge cooling fan does not reach the specified speed.	<ol style="list-style-type: none"> <li>1. Check for cooling fan obstructions.</li> <li>2. Check the connections on the main cooling fan.</li> <li>3. Replace the print cartridge cooling fan. Go to <b>“Print cartridge cooling fan removal (T650, T652, T654)” on page 4-57.</b></li> </ol>
927.14	Print cartridge cooling fan underspeed failure	The Print cartridge cooling fan does not reach the specified speed.	<ol style="list-style-type: none"> <li>1. Check for cooling fan obstructions.</li> <li>2. Check the connections on the main cooling fan.</li> <li>3. Replace the print cartridge cooling fan. Go to <b>“Print cartridge cooling fan removal (T650, T652, T654)” on page 4-57.</b></li> </ol>
927.15	Print cartridge cooling fan over speed failure.	The Print cartridge cooling fan does not reach the specified speed.	<ol style="list-style-type: none"> <li>1. Check for cooling fan obstructions.</li> <li>2. Check the connections on the main cooling fan.</li> <li>3. Replace the print cartridge cooling fan. Go to <b>“Print cartridge cooling fan removal (T650, T652, T654)” on page 4-57.</b></li> </ol>
927.16	Print cartridge cooling fan over speed failure.	The Print cartridge cooling fan does not reach the specified speed.	<ol style="list-style-type: none"> <li>1. Check for cooling fan obstructions.</li> <li>2. Check the connections on the main cooling fan.</li> <li>3. Replace the print cartridge cooling fan. Go to <b>“Print cartridge cooling fan removal (T650, T652, T654)” on page 4-57.</b></li> </ol>



Error code or message	Error contents	Description/Action	Possible repair actions
927.17	Print cartridge cooling fan over speed failure.	The Print cartridge cooling fan does not reach the specified speed.	<ol style="list-style-type: none"> <li>1. Check for cooling fan obstructions.</li> <li>2. Check the connections on the main cooling fan.</li> <li>3. Replace the print cartridge cooling fan. Go to <b>“Print cartridge cooling fan removal (T650, T652, T654)” on page 4-57.</b></li> </ol>
929.01	Sensor (toner empty) sensor failure.	The sensor (toner empty) does not provide toner level feedback or the print cartridge is damaged.	<ol style="list-style-type: none"> <li>1. Check the toner pulse wheel on the print cartridge for damage and replace the print cartridge if needed.</li> <li>2. Check the sensor (toner empty) for proper operation. See <b>“Sensor (toner empty) service check” on page 2-155.</b></li> </ol>
929.02	Sensor (toner empty) sensor failure.	The sensor (toner empty) does not provide toner level feedback or the print cartridge is damaged.	<ol style="list-style-type: none"> <li>1. Check the toner pulse wheel on the print cartridge for damage and replace the print cartridge if needed.</li> <li>2. Check the sensor (toner empty) for proper operation. See <b>“Sensor (toner empty) service check” on page 2-155.</b></li> </ol>
929.03	Sensor (toner empty) sensor failure.	The sensor (toner empty) does not provide toner level feedback or the print cartridge is damaged.	<ol style="list-style-type: none"> <li>1. Check the toner pulse wheel on the print cartridge for damage and replace the print cartridge if needed.</li> <li>2. Check the sensor (toner empty) for proper operation. See <b>“Sensor (toner empty) service check” on page 2-155.</b></li> </ol>
930.00	Incorrect printhead or intermittent Hsync	A non supported printhead is installed. Hsync signal is intermittent or noisy. Printhead ID resistor circuit is not to spec.	Replace the printhead assembly. Go to <b>“Printhead assembly removal (T650)” on page 4-60</b> or <b>“Printhead assembly removal (T652, T654)” on page 4-61.</b>
931.00	No first laser H sync	The hsync signal is missing or not at the correct voltage.	Replace the printhead assembly. Go to <b>“Printhead assembly removal (T650)” on page 4-60</b> or <b>“Printhead assembly removal (T652, T654)” on page 4-61.</b>
932.00	Printhead lost laser H syncs.	The hsync signal is missing or not at the correct voltage.	Replace the printhead assembly. Go to <b>“Printhead assembly removal (T650)” on page 4-60</b> or <b>“Printhead assembly removal (T652, T654)” on page 4-61.</b>

Error code or message	Error contents	Description/Action	Possible repair actions
933.00	Polygon mirror motor locked. No first laser H sync received.	The hsync signal is missing or not at the correct voltage.	Replace the printhead assembly. Go to <b>“Printhead assembly removal (T650)” on page 4-60</b> or <b>“Printhead assembly removal (T652, T654)” on page 4-61</b> .
934.00	Mirror motor lost lock.	The signals driving the polygon motor may have been corrupted, or the cable may be loose, or the motor may be bad.	<ol style="list-style-type: none"> <li>1. Check all connections on the printhead assembly.</li> <li>2. Check all connections on the system card assembly.</li> <li>3. Replace the printhead assembly. Go to <b>“Printhead assembly removal (T650)” on page 4-60</b> or <b>“Printhead assembly removal (T652, T654)” on page 4-61</b>.</li> </ol>
935.00	Polygon mirror motor control failure.	The signals driving the polygon mirror motor may have been corrupted, or the cable may be loose, or the motor may be bad.	<ol style="list-style-type: none"> <li>1. Check all connections on the printhead assembly.</li> <li>2. Check all connections on the system card assembly.</li> <li>3. Replace the printhead assembly. Go to <b>“Printhead assembly removal (T650)” on page 4-60</b> or <b>“Printhead assembly removal (T652, T654)” on page 4-61</b>.</li> </ol>
936.10	Main drive motor assembly failure No halls detected at motor start. Motor = type 0	The main drive motor assembly may be faulty or has failed.	<ol style="list-style-type: none"> <li>1. Check all connections on the system card assembly.</li> <li>2. Check all connections on the main drive motor assembly.</li> <li>3. Replace the main drive motor assembly. Go to <b>“Output cover assembly removal (T650, T652, T654)” on page 4-54</b>.</li> <li>4. Replace the system card assembly if problem remains. Go to <b>“System card assembly removal (T650, T652, T654, T656)” on page 4-76</b>.</li> </ol>
936.11	Main drive motor assembly failure No halls detected at motor start. Motor = type 1	The main drive motor assembly may be faulty or has failed.	<ol style="list-style-type: none"> <li>1. Check all connections on the system card assembly.</li> <li>2. Check all connections on the main drive motor assembly.</li> <li>3. Replace the main drive motor assembly. Go to <b>“Output cover assembly removal (T650, T652, T654)” on page 4-54</b>.</li> <li>4. Replace the system card assembly if problem remains. Go to <b>“System card assembly removal (T650, T652, T654, T656)” on page 4-76</b>.</li> </ol>

Error code or message	Error contents	Description/Action	Possible repair actions
936.20	Main drive motor assembly failure Failed to stop within timeout. Motor = type 0	The main drive motor assembly may be faulty or has failed.	<ol style="list-style-type: none"> <li>1. Check all connections on the system card assembly.</li> <li>2. Check all connections on the main drive motor assembly.</li> <li>3. Replace the main drive motor assembly. Go to <b>“Output cover assembly removal (T650, T652, T654)” on page 4-54.</b></li> <li>4. Replace the system card assembly if problem remains. Go to <b>“System card assembly removal (T650, T652, T654, T656)” on page 4-76.</b></li> </ol>
936.21	Main drive motor assembly failure Failed to stop within timeout. Motor = type 1	The main drive motor assembly may be faulty or has failed.	<ol style="list-style-type: none"> <li>1. Check all connections on the system card assembly.</li> <li>2. Check all connections on the main drive motor assembly.</li> <li>3. Replace the main drive motor assembly. Go to <b>“Output cover assembly removal (T650, T652, T654)” on page 4-54.</b></li> <li>4. Replace the system card assembly if problem remains. Go to <b>“System card assembly removal (T650, T652, T654, T656)” on page 4-76.</b></li> </ol>
936.30	Main drive motor assembly failure No lock detected at motor start for motor ID. Motor = type 0	The main drive motor assembly may be faulty or has failed.	<ol style="list-style-type: none"> <li>1. Check all connections on the system card assembly.</li> <li>2. Check all connections on the main drive motor assembly.</li> <li>3. Replace the main drive motor assembly. Go to <b>“Output cover assembly removal (T650, T652, T654)” on page 4-54.</b></li> <li>4. Replace the system card assembly if problem remains. Go to <b>“System card assembly removal (T650, T652, T654, T656)” on page 4-76.</b></li> </ol>

Error code or message	Error contents	Description/Action	Possible repair actions
936.31	Main drive motor assembly failure No lock detected at motor start for motor ID. Motor = type 1	The main drive motor assembly may be faulty or has failed.	<ol style="list-style-type: none"> <li>1. Check all connections on the system card assembly.</li> <li>2. Check all connections on the main drive motor assembly.</li> <li>3. Replace the main drive motor assembly. Go to <b>“Output cover assembly removal (T650, T652, T654)” on page 4-54.</b></li> <li>4. Replace the system card assembly if problem remains. Go to <b>“System card assembly removal (T650, T652, T654, T656)” on page 4-76.</b></li> </ol>
936.60	Main drive motor assembly failure No lock detected at normal motor start. Motor = type 0	The main drive motor assembly may be faulty or has failed.	<ol style="list-style-type: none"> <li>1. Check all connections on the system card assembly.</li> <li>2. Check all connections on the main drive motor assembly.</li> <li>3. Replace the main drive motor assembly. Go to <b>“Output cover assembly removal (T650, T652, T654)” on page 4-54.</b></li> <li>4. Replace the system card assembly if problem remains. Go to <b>“System card assembly removal (T650, T652, T654, T656)” on page 4-76.</b></li> </ol>
936.61	Main drive motor assembly failure No lock detected at normal motor start. Motor = type 1	The main drive motor assembly may be faulty or has failed.	<ol style="list-style-type: none"> <li>1. Check all connections on the system card assembly.</li> <li>2. Check all connections on the main drive motor assembly.</li> <li>3. Replace the main drive motor assembly. Go to <b>“Output cover assembly removal (T650, T652, T654)” on page 4-54.</b></li> <li>4. Replace the system card assembly if problem remains. Go to <b>“System card assembly removal (T650, T652, T654, T656)” on page 4-76.</b></li> </ol>

Error code or message	Error contents	Description/Action	Possible repair actions
936.90	Main drive motor assembly failure Stall detected during speed control. Motor = type 0	The main drive motor assembly may be faulty or has failed.	<ol style="list-style-type: none"> <li>1. Check all connections on the system card assembly.</li> <li>2. Check all connections on the main drive motor assembly.</li> <li>3. Replace the main drive motor assembly. Go to <b>“Output cover assembly removal (T650, T652, T654)” on page 4-54.</b></li> <li>4. Replace the system card assembly if problem remains. Go to <b>“System card assembly removal (T650, T652, T654, T656)” on page 4-76.</b></li> </ol>
936.91	Main drive motor assembly failure Stall detected during speed control. Motor = type 1	The main drive motor assembly may be faulty or has failed.	<ol style="list-style-type: none"> <li>1. Check all connections on the system card assembly.</li> <li>2. Check all connections on the main drive motor assembly.</li> <li>3. Replace the main drive motor assembly. Go to <b>“Output cover assembly removal (T650, T652, T654)” on page 4-54.</b></li> <li>4. Replace the system card assembly if problem remains. Go to <b>“System card assembly removal (T650, T652, T654, T656)” on page 4-76.</b></li> </ol>
937.40	Main drive motor assembly failure Over speed detected during speed control. Motor = type 0	The main drive motor assembly may be faulty or has failed.	<ol style="list-style-type: none"> <li>1. Check all connections on the system card assembly.</li> <li>2. Check all connections on the main drive motor assembly.</li> <li>3. Replace the main drive motor assembly. Go to <b>“Output cover assembly removal (T650, T652, T654)” on page 4-54.</b></li> <li>4. Replace the system card assembly if problem remains. Go to <b>“System card assembly removal (T650, T652, T654, T656)” on page 4-76.</b></li> </ol>

Error code or message	Error contents	Description/Action	Possible repair actions
937.41	Main drive motor assembly failure Over speed detected during speed control. Motor = type 1	The main drive motor assembly may be faulty or has failed.	<ol style="list-style-type: none"> <li>1. Check all connections on the system card assembly.</li> <li>2. Check all connections on the main drive motor assembly.</li> <li>3. Replace the main drive motor assembly. Go to <b>“Output cover assembly removal (T650, T652, T654)” on page 4-54.</b></li> <li>4. Replace the system card assembly if problem remains. Go to <b>“System card assembly removal (T650, T652, T654, T656)” on page 4-76.</b></li> </ol>
937.50	Main drive motor assembly failure Over speed detected during position control. Motor = type 0	The main drive motor assembly may be faulty or has failed.	<ol style="list-style-type: none"> <li>1. Check all connections on the system card assembly.</li> <li>2. Check all connections on the main drive motor assembly.</li> <li>3. Replace the main drive motor assembly. Go to <b>“Output cover assembly removal (T650, T652, T654)” on page 4-54.</b></li> <li>4. Replace the system card assembly if problem remains. Go to <b>“System card assembly removal (T650, T652, T654, T656)” on page 4-76.</b></li> </ol>
937.51	Main drive motor assembly failure Over speed detected during position control. Motor = type 1	The main drive motor assembly may be faulty or has failed.	<ol style="list-style-type: none"> <li>1. Check all connections on the system card assembly.</li> <li>2. Check all connections on the main drive motor assembly.</li> <li>3. Replace the main drive motor assembly. Go to <b>“Output cover assembly removal (T650, T652, T654)” on page 4-54.</b></li> <li>4. Replace the system card assembly if problem remains. Go to <b>“System card assembly removal (T650, T652, T654, T656)” on page 4-76.</b></li> </ol>

Error code or message	Error contents	Description/Action	Possible repair actions
937.70	Main drive motor assembly failure Loss of lock detected by higher-level code. Motor = type 0	The main drive motor assembly may be faulty or has failed.	<ol style="list-style-type: none"> <li>1. Check all connections on the system card assembly.</li> <li>2. Check all connections on the main drive motor assembly.</li> <li>3. Replace the main drive motor assembly. Go to <b>“Output cover assembly removal (T650, T652, T654)” on page 4-54.</b></li> <li>4. Replace the system card assembly if problem remains. Go to <b>“System card assembly removal (T650, T652, T654, T656)” on page 4-76.</b></li> </ol>

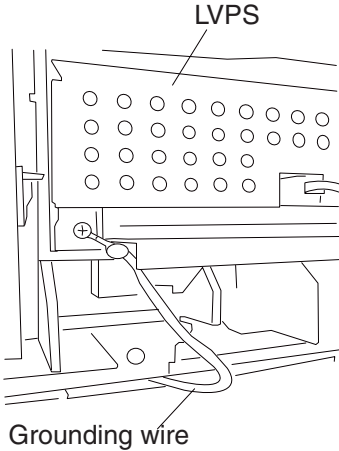
Error code or message	Error contents	Description/Action	Possible repair actions
937.71	<p>Main drive motor assembly failure</p> <p>Loss of lock detected by higher-level code.</p> <p>Motor = type 1</p>	<p>The main drive motor assembly may be faulty or has failed.</p> <p>The internal duplex assembly is not properly grounded to the LVPS. This only applies to machines with an installed internal duplex assembly.</p>	<p><b>Warning:</b> Ensure that the metal frame of the internal duplex assembly is properly grounded to the metal frame of the LVPS with a jumper wire as shown in the graphic below.</p>  <p>The diagram shows a side view of the LVPS (Linear Voltage Regulator Power Supply) assembly. It features a metal frame with a grid of circular components. A grounding wire is shown connected from the bottom of the LVPS assembly to the metal frame of the machine.</p> <p>If the jumper wire is NOT present, install the <b>40X7028</b> internal duplex grounding kit. This should only be done for machines with an installed internal duplex assembly.</p> <ol style="list-style-type: none"> <li>1. Check all connections on the system card assembly.</li> <li>2. Check all connections on the main drive motor assembly.</li> <li>3. Replace the main drive motor assembly. Go to <b>“Output cover assembly removal (T650, T652, T654)” on page 4-54.</b></li> <li>4. Replace the system card assembly if problem remains. Go to <b>“System card assembly removal (T650, T652, T654, T656)” on page 4-76.</b></li> </ol>



Error code or message	Error contents	Description/Action	Possible repair actions
937.80	Main drive motor assembly failure Driver over temp detection. Motor = type 0	The main drive motor assembly may be faulty or has failed.	<ol style="list-style-type: none"> <li>1. Check all connections on the system card assembly.</li> <li>2. Check all connections on the main drive motor assembly.</li> <li>3. Replace the main drive motor assembly. Go to <b>“Output cover assembly removal (T650, T652, T654)” on page 4-54.</b></li> <li>4. Replace the system card assembly if problem remains. Go to <b>“System card assembly removal (T650, T652, T654, T656)” on page 4-76.</b></li> </ol>
937.81	Main drive motor assembly failure Driver over temp detection. Motor = type 1	The main drive motor assembly may be faulty or has failed.	<ol style="list-style-type: none"> <li>1. Check all connections on the system card assembly.</li> <li>2. Check all connections on the main drive motor assembly.</li> <li>3. Replace the main drive motor assembly. Go to <b>“Output cover assembly removal (T650, T652, T654)” on page 4-54.</b></li> <li>4. Replace the system card assembly if problem remains. Go to <b>“System card assembly removal (T650, T652, T654, T656)” on page 4-76.</b></li> </ol>
939.00	System card failure	RIP-engine communication lost.	<p>Replace the system card assembly.</p> <p>Go to <b>“System card assembly removal (T650, T652, T654, T656)” on page 4-76.</b></p>
940.00	System card failure	LVPS zero-crossing test failed.	<p>Replace the system card assembly.</p> <p>Go to <b>“System card assembly removal (T650, T652, T654, T656)” on page 4-76.</b></p>
947.00	System card failure	RAM test incomplete.	<p>Replace the system card assembly.</p> <p>Go to <b>“System card assembly removal (T650, T652, T654, T656)” on page 4-76.</b></p>
948.00	System card failure	Pel clock check failed.	<p>Replace the system card assembly.</p> <p>Go to <b>“System card assembly removal (T650, T652, T654, T656)” on page 4-76.</b></p>

Error code or message	Error contents	Description/Action	Possible repair actions
949.00	System card failure	Delay line calibration failure.	Replace the system card assembly. Go to <b>“System card assembly removal (T650, T652, T654, T656)”</b> on page 4-76.
950.xx	NVRAM mismatch failure	Mismatch between system card EEPROM and operator panel mirror. ".xx" codes: 00-29: mismatch between system and mirror 30-60: mismatch between secure and system	<b>Warning:</b> When replacing any of the following components: <ul style="list-style-type: none"> <li>• Operator panel assembly</li> <li>• System card assembly</li> </ul> Only replace one component at a time. Replace the required component and perform a POR before replacing a second component listed above. If this procedure is not followed, the printer will be rendered inoperable. Never replace two or more of the components listed above without a POR after installing each one or the printer will be rendered inoperable.  Never install and remove components listed above as a method of troubleshooting components. Once a component has been installed in a machine, it can not be used in another machine. It must be returned to the manufacturer.  Go to NVRAM mismatch failure service check.  See <b>“NVRAM mismatch failure (950.00 through 950.29) service check”</b> on page 2-155.
952.xx	NVRAM failure	A recoverable MVRAM Cyclic Redundancy Check (CRC) error occurred.	Power the machine off/on to reset the error condition.
953.xx	NVRAM failure	The NVRAM chip has failed on the operator panel door assembly.	Replace the operator panel door assembly. Go to <b>“Operator panel door assembly removal (T650, T652, T654)”</b> on page 4-44.  If problem remains, replace the fuser unit assembly.  Go to <b>“Fuser unit assembly removal (T650, T652, T654)”</b> on page 4-23.

Error code or message	Error contents	Description/Action	Possible repair actions
954.xx	NVRAM failure	NVRAM chip failure with system card assembly.	Replace the system card assembly. Go to <b>“System card assembly removal (T650, T652, T654, T656)”</b> on page 4-76.
955.xx	NVRAM failure	The Code ROM or NAND flash failed the Cyclic Redundancy Check (CRC) check or the NAND experienced an uncorrectible multi-bit failure.	Replace the system card assembly. Go to <b>“System card assembly removal (T650, T652, T654, T656)”</b> on page 4-76.
956.xx	System card processor failure	The processor has failed on the system card assembly.	Replace the system card assembly. Go to <b>“System card assembly removal (T650, T652, T654, T656)”</b> on page 4-76.
956.01	System card processor over temperature	The system card processor is over temperature or is damaged.	Replace the system card assembly. Go to <b>“System card assembly removal (T650, T652, T654, T656)”</b> on page 4-76.
957.xx	System card ASIC failure	The ASIC has failed on the system card assembly.	Replace the system card assembly. Go to <b>“System card assembly removal (T650, T652, T654, T656)”</b> on page 4-76.
958.xx	NAND failure	Printer has performed more than 100 "shift and reflash" operations as a result of ECC bit corrections	Replace the system card assembly. Go to <b>“System card assembly removal (T650, T652, T654, T656)”</b> on page 4-76.
959.xx	Print cartridge authentication failure	The system card can not properly authenticate the print cartridge or the authentication process has failed.	Replace the system card assembly. Go to <b>“System card assembly removal (T650, T652, T654, T656)”</b> on page 4-76.
960.xx	Memory failure	RAM Memory Error: RAM soldered on the card is bad	Replace the appropriate memory module.
961.xx	Memory failure	RAM Memory Error: Slot 1 RAM is bad	Replace the appropriate memory module.
962.xx	Memory failure	RAM Memory Error: Slot 2 RAM is bad	Replace the appropriate memory module.
963.xx	Memory failure	RAM Memory Error: Slot 3 RAM is bad	Replace the appropriate memory module.

Error code or message	Error contents	Description/Action	Possible repair actions
964.xx	Emulation failure	The download Emulation Cyclic Redundancy Check (CRC) detected a failure.	<p>1. Disable the Download Emulation. Program the download emulation into the firmware card again.</p> <p>2. Replace the system card assembly if problem remains.</p> <p>Go to <b>“System card assembly removal (T650, T652, T654, T656)” on page 4-76.</b></p>
975.xx	Network Error	The system detected an unrecognizable network port	<p>Replace the system card assembly.</p> <p>Go to <b>“System card assembly removal (T650, T652, T654, T656)” on page 4-76.</b></p>
976.xx	Network Error	The system detected an unrecoverable software error in network port	<p>Replace the system card assembly.</p> <p>Go to <b>“System card assembly removal (T650, T652, T654, T656)” on page 4-76.</b></p>
978.xx	Network Error	The system detected a bad checksum while programming network port	<p>Replace the system card assembly.</p> <p>Go to <b>“System card assembly removal (T650, T652, T654, T656)” on page 4-76.</b></p>
979.xx	Network Error	The flash parts failed while programming a network port	<p>Replace the system card assembly.</p> <p>Go to <b>“System card assembly removal (T650, T652, T654, T656)” on page 4-76.</b></p>
980.00	Communication failure	The engine is experiencing unreliable communications to the paper port device.	<p>Replace the system card assembly.</p> <p>Go to <b>“System card assembly removal (T650, T652, T654, T656)” on page 4-76.</b></p>
981.00	Communication failure	The engine protocol violation detected by the paper port device.	<p>Replace the system card assembly.</p> <p>Go to <b>“System card assembly removal (T650, T652, T654, T656)” on page 4-76.</b></p>
982.00	Communication failure	Communications error detected by the paper port device.	<p>Replace the system card assembly.</p> <p>Go to <b>“System card assembly removal (T650, T652, T654, T656)” on page 4-76.</b></p>

Error code or message	Error contents	Description/Action	Possible repair actions
982.01	Communication failure	Paper port communication device detected a validation failure.	Replace the system card assembly. Go to <b>“System card assembly removal (T650, T652, T654, T656)” on page 4-76.</b>
982.02	Communication failure	Paper port communication device detected a framing error or the receive buffer overflowed.	Replace the system card assembly. Go to <b>“System card assembly removal (T650, T652, T654, T656)” on page 4-76.</b>
982.03	Communication failure	Paper port communication device timed out during communication.	Replace the system card assembly. Go to <b>“System card assembly removal (T650, T652, T654, T656)” on page 4-76.</b>
982.04	Output option communication failure.	An output option was not fully seated onto the printer or has been removed while the main power is turned on.	<ol style="list-style-type: none"> <li>1. Turn the main power off.</li> <li>2. Remove and reinstall the output option.</li> <li>3. Turn the main power back on.</li> <li>4. Check all output option interface connections if problem remains.</li> </ol>
982.06	Paperport failure	Paper port prioritizer error. Option device message was not read by the prioritizer.	Replace the system card assembly. Go to <b>“System card assembly removal (T650, T652, T654, T656)” on page 4-76.</b>
982.07	Too many options installed	Exceeded the maximum number of input or output options.	Remove the appropriate input or output options.
982.11	Paperport failure	Command response error on the paper port. Response is too large for the communications buffer.	Replace the system card assembly. Go to <b>“System card assembly removal (T650, T652, T654, T656)” on page 4-76.</b>
982.12	Paperport failure	Bad bottom trunk on the paper port.	Replace the system card assembly. Go to <b>“System card assembly removal (T650, T652, T654, T656)” on page 4-76.</b>
982.13	Hot plug failure	The printer has detected a hot plug of an optional device. Low-level error on paper port.	Power the machine off/on after all options are installed.

Error code or message	Error contents	Description/Action	Possible repair actions
983.00	Communication failure	Invalid command received by the paper port device.	Replace the system card assembly. Go to <b>“System card assembly removal (T650, T652, T654, T656)”</b> on page 4-76.
984.00	Communication failure	Invalid command parameter received by the paper port device.	Replace the system card assembly. Go to <b>“System card assembly removal (T650, T652, T654, T656)”</b> on page 4-76.
985.01	Service engine RFID communications	Generic hardware error	<ol style="list-style-type: none"> <li>1. Check the RFID firmware card, RFID interface card, RFID cable, and RFID option for correct installation. Go to <b>“High capacity input tray (HCIT) pick arm bracket assembly removal”</b> on page 4-130.</li> <li>2. Replace the RFID UHF option.</li> </ol> <p><b>Note:</b> There can be no other connectivity options installed on printers that have the RFID UHF option installed. If any connectivity option is installed (other than the RFID interface card), a 985.xx error will occur</p>
985.02	Service engine RFID communications	Printer having problems communicating with radio	<ol style="list-style-type: none"> <li>1. Check the RFID firmware card, RFID interface card, RFID cable, and RFID option for correct installation. Go to <b>“High capacity input tray (HCIT) pick arm bracket assembly removal”</b> on page 4-130.</li> <li>2. Replace the RFID UHF option.</li> </ol> <p><b>Note:</b> There can be no other connectivity options installed on printers that have the RFID UHF option installed. If any connectivity option is installed (other than the RFID interface card), a 985.xx error will occur</p>

Error code or message	Error contents	Description/Action	Possible repair actions
985.03	Service engine RFID communications	Radio having problems communicating with printer	<p>1. Check the RFID firmware card, RFID interface card, RFID cable, and RFID option for correct installation. Go to <b>“High capacity input tray (HCIT) pick arm bracket assembly removal” on page 4-130.</b></p> <p>2. Replace the RFID UHF option.</p> <p><b>Note:</b> There can be no other connectivity options installed on printers that have the RFID UHF option installed. If any connectivity option is installed (other than the RFID interface card), a 985.xx error will occur</p>
985.04	Service engine RFID communications	Radio communications are out of sync	<p>1. Check the RFID firmware card, RFID interface card, RFID cable, and RFID option for correct installation. Go to <b>“High capacity input tray (HCIT) pick arm bracket assembly removal” on page 4-130.</b></p> <p>2. Replace the RFID UHF option.</p> <p><b>Note:</b> There can be no other connectivity options installed on printers that have the RFID UHF option installed. If any connectivity option is installed (other than the RFID interface card), a 985.xx error will occur</p>

Error code or message	Error contents	Description/Action	Possible repair actions
985.05	Service engine RFID communications	Internal radio problem	<p>1. Check the RFID firmware card, RFID interface card, RFID cable, and RFID option for correct installation. Go to <b>“High capacity input tray (HCIT) pick arm bracket assembly removal” on page 4-130.</b></p> <p>2. Replace the RFID UHF option.</p> <p><b>Note:</b> There can be no other connectivity options installed on printers that have the RFID UHF option installed. If any connectivity option is installed (other than the RFID interface card), a 985.xx error will occur</p>
985.06	Service engine RFID communications	Radio reported antenna problem	<p>1. Check the RFID firmware card, RFID interface card, RFID cable, and RFID option for correct installation. Go to <b>“High capacity input tray (HCIT) pick arm bracket assembly removal” on page 4-130.</b></p> <p>2. Replace the RFID UHF option.</p> <p><b>Note:</b> There can be no other connectivity options installed on printers that have the RFID UHF option installed. If any connectivity option is installed (other than the RFID interface card), a 985.xx error will occur</p>



Error code or message	Error contents	Description/Action	Possible repair actions
985.07	Service engine RFID communications	Antenna is disconnected	<p>1. Check the RFID firmware card, RFID interface card, RFID cable, and RFID option for correct installation. Go to <b>“High capacity input tray (HCIT) pick arm bracket assembly removal”</b> on page 4-130.</p> <p>2. Replace the RFID UHF option.</p> <p><b>Note:</b> There can be no other connectivity options installed on printers that have the RFID UHF option installed. If any connectivity option is installed (other than the RFID interface card), a 985.xx error will occur</p>
990.00	Output option equipment check.	Output option rear door not fully closed.	Close the rear door on all output options.
990.02	Paperport failure	Invalid paperport parameter	<p>Replace the system card assembly.</p> <p>Go to <b>“System card assembly removal (T650, T652, T654, T656)”</b> on page 4-76.</p>
990.03	Paperport failure	Invalid paperport protocol	<p>Replace the system card assembly.</p> <p>Go to <b>“System card assembly removal (T650, T652, T654, T656)”</b> on page 4-76.</p>
990.04	Paperport failure	Unsupported paperport command	<p>Replace the system card assembly.</p> <p>Go to <b>“System card assembly removal (T650, T652, T654, T656)”</b> on page 4-76.</p>
990.06	Paperport failure	Unknown page supervisor state	<p>Replace the system card assembly.</p> <p>Go to <b>“System card assembly removal (T650, T652, T654, T656)”</b> on page 4-76.</p>
990.09	Paperport failure	Paperport framing error	<p>Replace the system card assembly.</p> <p>Go to <b>“System card assembly removal (T650, T652, T654, T656)”</b> on page 4-76.</p>

Error code or message	Error contents	Description/Action	Possible repair actions
990.10	Paperport failure	Paperport overrun error	Replace the system card assembly. Go to <b>“System card assembly removal (T650, T652, T654, T656)” on page 4-76.</b>
990.11	Paperport failure	Paperport parity error	Replace the system card assembly. Go to <b>“System card assembly removal (T650, T652, T654, T656)” on page 4-76.</b>
990.12	Paperport failure	Paper port other paper port error	Replace the system card assembly. Go to <b>“System card assembly removal (T650, T652, T654, T656)” on page 4-76.</b>
990.13	Paperport failure	Paperport encountered multiple communication error	Replace the system card assembly. Go to <b>“System card assembly removal (T650, T652, T654, T656)” on page 4-76.</b>
990.14	Paperport failure	Invalid paperport echo	Replace the system card assembly. Go to <b>“System card assembly removal (T650, T652, T654, T656)” on page 4-76.</b>
990.51	HCIT tray lift motor PWM underflow error	The HCIT tray lift motor does not operate at the specified speed reported by tray x	<ol style="list-style-type: none"> <li>1. Check for obstruction in the HCIT tray lift area.</li> <li>2. Check the connections on the HCIT tray lift motor assembly for proper connection.</li> <li>3. Replace the HCIT tray lift motor drive motor assembly if problem remains. Go to <b>“High capacity input tray (HCIT) tray lift drive motor assembly removal” on page 4-125.</b></li> </ol>
990.53	HCIT tray lift motor ramp error	The HCIT tray lift motor does not reach the specified speed at the specified time.	<ol style="list-style-type: none"> <li>1. Check for obstruction in the HCIT tray lift area.</li> <li>2. Check the connections on the HCIT tray lift motor assembly for proper connection.</li> <li>3. Replace the HCIT tray lift drive motor assembly if problem remains. Go to <b>“High capacity input tray (HCIT) tray lift drive motor assembly removal” on page 4-125.</b></li> </ol>

Error code or message	Error contents	Description/Action	Possible repair actions
990.54	HCIT tray lift motor lost encoder failure	The HCIT tray lift motor is not reporting pulses back to the engine.	<ol style="list-style-type: none"> <li>1. Check for obstruction in the HCIT tray lift area.</li> <li>2. Check the connections on the HCIT tray lift motor assembly for proper connection.</li> <li>3. Replace the HCIT tray lift drive motor assembly if problem remains. Go to <b>“High capacity input tray (HCIT) tray lift drive motor assembly removal” on page 4-125</b></li> </ol>
990.90	Sensor connection failure	Hardware error (sensors are not plugged on the board)	Replace all connections on the system card assembly.
991.00	System card failure	Device system card failed basic assurance test.	<p>Replace the system card assembly.</p> <p>Go to <b>“System card assembly removal (T650, T652, T654, T656)” on page 4-76.</b></p>
991.05	Checksum failure	Bad checksum	<p>Replace the system card assembly.</p> <p>Go to <b>“System card assembly removal (T650, T652, T654, T656)” on page 4-76.</b></p>

## Service checks

### Sensor (input) service check

Step	Check	Yes	No
1	Check the sensor (input) for damage. Is the above component free from damage?	Go to step 2.	Replace the sensor (input). Go to <b>“Sensor (input) removal (T650, T652, T654)” on page 4-71.</b>
2	1. Enter the diagnostic mode 2. Select Base sensor test 4. Observe the line item “input” Does the display on the operator panel, change every time the sensing area of the above sensor is interrupted or blocked.	The sensor is working properly	Go to step 2.
3	Check the above sensor for proper connection. Is the above sensor connected properly?	Replace the Sensor (input). Go to <b>“Sensor (input) removal (T650, T652, T654)” on page 4-71.</b>	Replace the connection.

### Sensor (fuser output) service check

Step	Check	Yes	No
1	Check the sensor (fuser output) for damage. Is the above component free from damage?	Go to step 2.	Replace fuser unit assembly. Go to <b>“Fuser unit assembly removal (T650, T652, T654)” on page 4-23.</b>
2	1. Enter the diagnostic mode 2. Select Base sensor test 4. Observe the line item “exit” Does the display on the operator panel, change every time the sensing area of the above sensor is interrupted or blocked.	The sensor is working properly	Go to step 2.
3	Check the above sensor for proper connection. Is the above sensor connected properly?	Replace the fuser unit assembly. Go to <b>“Fuser unit assembly removal (T650, T652, T654)” on page 4-23.</b>	Replace the connection.

### Sensor (narrow media) service check

Step	Check	Yes	No
1	Check the sensor (narrow media) for damage. Is the above component free from damage?	Go to step 2.	Replace the fuser unit assembly. Go to <b>“Fuser unit assembly removal (T650, T652, T654)” on page 4-23.</b>
2	1. Enter the diagnostic mode 2. Select Base sensor test 4. Observe the line item “narrow media” Does the display on the operator panel, change every time the sensing area of the above sensor is interrupted or blocked.	The sensor is working properly	Go to step 2.
3	Check the above sensor for proper connection. Is the above sensor connected properly?	Replace fuser unit assembly. Go to <b>“Fuser unit assembly removal (T650, T652, T654)” on page 4-23.</b>	Replace the connection.

### Sensor (duplex input) service check

Step	Check	Yes	No
1	Check the sensor (duplex input) for damage. Is the above component free from damage?	Go to step 2.	Replace the sensor (duplex input). Go to <b>“Sensor (duplex input) removal (T652, T654)” on page 4-68.</b>
2	1. Enter the diagnostic mode 2. Select Duplex sensor tests 3. Select Sensor test 4. Observe the line item “input” Does the display on the operator panel, change every time the sensing area of the above sensor is interrupted or blocked.	The sensor is working properly	Go to step 2.

Step	Check	Yes	No
3	Check the above sensor for proper connection. Is the above sensor connected properly?	Replace the duplex input sensor assembly (internal duplex only).  Go to " <b>Duplex input sensor assembly removal (T652, T654)</b> " on <b>page 4-20</b>  or replace the external duplex unit assembly (external duplex only).	Replace the connection.

### Sensor (duplex input) service check (external duplex only)

Step	Check	Yes	No
1	Check the sensor (duplex input) for damage. Is the above component free from damage?	Go to step 2.	Replace the external duplex unit assembly.
2	1. Enter the diagnostic mode 2. Select Duplex sensor tests 3. Select Sensor test 4. Observe the line item "input"  Does the display on the operator panel, change every time the sensing area of the above sensor is interrupted or blocked.	The sensor is working properly	Go to step 2.
3	Check the above sensor for proper connection. Is the above sensor connected properly?	Replace the external duplex unit assembly.	Replace the connection.

### Sensor (duplex exit) service check (external duplex only)

Step	Check	Yes	No
1	Check the sensor (duplex exit) for damage. Is the above component free from damage?	Go to step 2.	Replace the external duplex unit assembly.
2	1. Enter the diagnostic mode 2. Select Duplex sensor tests 3. Select Sensor test 4. Observe the line item "exit"  Does the display on the operator panel, change every time the sensing area of the above sensor is interrupted or blocked.	The sensor is working properly	Go to step 2.
3	Check the above sensor for proper connection. Is the above sensor connected properly?	Replace the external duplex unit assembly.	Replace the connection.

### Sensor (pass through) service check

Step	Check	Yes	No
1	1. Enter the diagnostic mode 2. Select Input tray tests 3. Select Sensor test 4. Select the appropriate tray number 5. Observe the line item "pass through" for the appropriate media tray  Does the display on the operator panel, change every time the sensing area of the above sensor is interrupted or blocked.	The sensor is working properly	Go to step 2.
2	Check the above sensor for proper connection. Is the above sensor connected properly?	Replace the sensor (pass through).  Go to <b>"250-sheet controller card assembly removal"</b> on page 4-106.	Replace the connection.

### Sensor (envelope feeder empty) service check

Step	Check	Yes	No
1	1. Enter the diagnostic mode 2. Select Input tray tests 3. Select Sensor test 4. Select Envelope feeder 5. Observe the line item "empty"  Does the display on the operator panel, change every time the sensing area of the above sensor is interrupted or blocked.	The sensor is working properly	Go to step 2.
2	Check the above sensor for proper connection. Is the above sensor connected properly?	Replace the envelope feeder.	Replace the connection.

### Sensor (input) late jam service check.

Use this procedure for the following jams:

- 200.07                      • 230.04                      • 230.06                      • 237.00                      • 239.11
- 241.06                      • 214.10                      • 241.11                      • 241.12                      • 241.14
- 241.15                      • 241.16                      • 241.18                      • 242.09                      • 250.03
- 250.06                      • 250.07                      • 250.08                      • 250.09                      • 250.10
- 250.11                      • 260.07                      • 260.10                      • 260.11                      • 260.12
- 260.14                      • 260.15                      • 260.16

Step	Check	Yes	No
1	Check the media size setup and tray guides for all media trays. Does the media size, in use, match the size set for all media trays?	Go to step 2.	Replace the media, or change the media size setup.
2	Check the media trays for overfilling. Are any of the media trays overfilled?	Remove any excess new media.	Go to step 3
3	Check the media condition in all media trays. Is any of the media in any of the media trays crumpled or damaged?	Replace the damaged media with new.	Go to step 4.
4	Check the media tray pass through areas for obstructions. Are the pass through areas in all the media trays free from obstructions?	Go to step 5.	Remove obstructions.
5	Check media origination. Did the media originate from the MPF?	Go to step 6.	Go to step 8.
6	Check the MPF pick roll assembly. Is the above component free of excess wear and contamination?	Go to step 7.	Clean or replace the MPF pick roll assembly. Go to <b>“MPF pick roll assembly removal (T650, T652, T654)” on page 4-38.</b>
7	Perform a MPF print test and check the MPF pick solenoid for proper operation. Does the above component operate properly?	Go to step 17.	Replace the MPF pick solenoid. Go to <b>“MPF pick solenoid assembly removal (T650, T652, T654)” on page 4-39.</b>
8	Check media origination. Did the media originate from the internal duplex?	Go to step 9	Go to step 13
9	Check the internal duplex media path for obstructions. Is the above component free from obstructions?	Go to step 10	Remove obstructions.
10	Check the sensor (duplex input) for proper operation. 1. Enter the diagnostic mode 2. Select Duplex tests 3. Select sensor test 4. Observe the line item “input” Does the display on the operator panel, change every time the sensing area of the above sensor is interrupted or blocked.	Go to step 12.	Go to step 11.
11	Check the above sensor for proper connection. Is the above sensor connected properly?	Replace the Sensor (duplex input). Go to <b>“Sensor (duplex input) removal (T652, T654)” on page 4-68.</b>	Replace the connection.



Step	Check	Yes	No
12	Perform a print test and check the duplex drive motor assembly for proper operation. Does the above component operate properly?	Go to step 17.	Replace the duplex drive motor assembly. Go to <b>“Duplex drive motor assembly removal (T652, T654)” on page 4-19.</b>
13	Check media origination. Did the media originate from the external duplex?	Go to step 14.	Go to step 16.
14	Check the sensor (duplex input) for proper operation. 1. Enter the diagnostic mode 2. Select Duplex tests 3. Select sensor test 3. Observe the line item “input” Does the display on the operator panel, change every time the sensing area of the above sensor is interrupted or blocked.	Go to step 15.	Replace the external duplex assembly.
15	Check the sensor (duplex exit) for proper operation. 1. Enter the diagnostic mode 2. Select Duplex tests 3. Select sensor test 3. Observe the line item “exist” Does the display on the operator panel, change every time the sensing area of the above sensor is interrupted or blocked.	Go to step 17.	Replace the external duplex assembly.
16	Check the two pick roll assemblies in the media tray being picked from. Are the above components free of excess wear and contamination?	Go to step 17.	Clean or replace the pick roll assembly. Go to <b>“Pick roll assembly removal (T650, T652, T654)” on page 4-57</b>
17	Check the aligner assembly for obstructions. Is the above component free from obstructions?	Go to step 18.	Remove obstructions.
18	Check the sensor (input) for proper operation. 1. Enter the diagnostic mode 2. Select Base sensor test 3. Observe the line item “input” Does the display on the operator panel, change every time the sensing area of the above sensor is interrupted or blocked.	The sensor is working properly. Go to step 20.	Go to step 19.
19	Check the above sensor for proper connection. Is the above sensor connected properly?	Replace the Sensor (input). Go to <b>“Sensor (input) removal (T650, T652, T654)” on page 4-71.</b>	Replace the connection.

Step	Check	Yes	No
20	Perform a print test and check the pick arm assembly. Is the media properly picked and advanced out of the media tray?	Go to step 21.	Replace the pick arm assembly. Go to <b>“Operator panel door assembly removal (models X651, X652, X654, and X656)”</b> on page 4-49.
21	Perform a print test and check the main motor assembly. Is the media properly transported and able to reach the sensor (input)?	Go to step 22.	Replace the main drive motor assembly. Go to <b>“Output cover assembly removal (T650, T652, T654)”</b> on page 4-54.
22	Perform a print test. Does the problem remain?	Contact next highest level of tech support.	Problem solved.

### Sensor (input) lingering jam service check.

Use this procedure for the following jams:

- 200.01                      • 200.02                      • 200.17                      • 200.18                      • 200.19
- 200.27                      • 200.28                      • 200.29                      • 200.37                      • 200.38
- 200.39                      • 200.47                      • 200.48                      • 200.49                      • 200.57
- 200.58                      • 200.59

Step	Check	Yes	No
1	Check the media size setup and tray guides for all media trays. Does the media size, in use, match the size set for all media trays?	Go to step 2.	Replace the media, or change the media size setup.
2	Check the fuser unit assembly for obstructions. Is the above component free of obstructions?	Remove obstructions.	Go to step 3.
3	Check the fuser unit assembly for excess wear and damage. Is the above component free of excess wear and damage?	Go to step 4.	Replace the fuser unit assembly. Go to <b>“Fuser unit assembly removal (T650, T652, T654)”</b> on page 4-23.
4	Check the sensor (input) for proper operation. 1. Enter the diagnostic mode 2. Select Base sensor test 3. Observe the line item “input” Does the display on the operator panel, change every time the sensing area of the above sensor is interrupted or blocked.	Go to step 6.	Go to step 5.

Step	Check	Yes	No
5	Check the above sensor for proper connection. Is the above sensor connected properly?	Replace the sensor (input). Go to <b>“Sensor (input) removal (T650, T652, T654)” on page 4-71.</b>	Replace the connection.
6	Check the sensor (fuser output) for proper operation. 1. Enter the diagnostic mode 2. Select Base sensor test 3. Observe the line item “exit”  Caution: The area around the actuator is very hot. Allow the fuser area to cool before proceeding. Does the display on the operator panel, change every time the sensing area of the above sensor is interrupted or blocked?	Go to step 8.	Go to step 7.
7	Check the above sensor for proper connection. Is the above sensor connected properly?	Replace the fuser unit assembly. Go to <b>“Fuser unit assembly removal (T650, T652, T654)” on page 4-23.</b>	Replace the connection.
8	Perform a print test and check the main motor assembly. Is the media properly transported and able to reach the sensor (fuser output)?	Replace the main drive motor assembly. Go to <b>“Output cover assembly removal (T650, T652, T654)” on page 4-54.</b>	Replace the connection.
9	Check the aligner assembly for obstructions. Is the above component free from obstructions?	Go to step 10.	Remove obstructions.
10	Perform a print test. Does the problem remain?	Contact next highest level of tech support.	Problem solved.

## Sensor (input) early jam service check

Use this procedure for the following jams:

- 200.04
- 200.06
- 200.08
- 200.14
- 200.33

Step	Check	Yes	No
1	Check media origination. Did the media originate from the MPF?	Go to step 2.	Go to step 5.

Step	Check	Yes	No
2	Check the MPF pick roll assembly. Is the above component free of excess wear and contamination?	Go to step 3.	Clean or replace the MPF pick roll assembly. Go to <b>“MPF pick roll assembly removal (T650, T652, T654)” on page 4-38.</b>
3	Perform a MPF print test and check the MPF pick solenoid for proper operation. Does the above component operate properly?	Go to step 4.	Replace the MPF pick solenoid. Go to <b>“MPF pick solenoid assembly removal (T650, T652, T654)” on page 4-39.</b>
4	Check the MPF lift plate assembly for damage. Is the above component free from damage?	Go to step 5.	Replace the MPF lift plate assembly. Go to <b>“MPF lift plate assembly removal (T650, T652, T654)” on page 4-37.</b>
5	Check all the media trays for proper media installation. Is the media properly installed in all the media trays?	Go to step 6.	Remove and properly re-install the media.
6	Check all of the media trays and the media path for partially fed media. Are the media trays and the media path free from any partially fed pieces of media?	Go to step 7.	Remove any pre-staged or jammed media.
7	Check the sensor (input) for proper operation. 1. Enter the diagnostic mode 2. Select Base sensor test 3. Observe the line item “input” Does the display on the operator panel, change every time the sensing area of the above sensor is interrupted or blocked.	Go to step 9.	Go to step 8.
8	Check the above sensor for proper connection. Is the above sensor connected properly?	Replace the Sensor (input). Go to <b>“Sensor (input) removal (T650, T652, T654)” on page 4-71.</b>	Replace the connection.
9	Perform a print test. Does the problem remain?	Contact next highest level of tech support.	Problem solved.

## Sensor (input) static jam service check

Use this procedure for the following jams:

- 200.13

Step	Check	Yes	No
1	Check the media path for partially fed or jammed media. Is the media path free from partially fed or jammed media?	Go to step 2.	Remove any pre-staged or jammed media.
2	Check the sensor (input) for proper operation. 1. Enter the diagnostic mode 2. Select Base sensor test 3. Observe the line item "input" Does the display on the operator panel, change every time the sensing area of the above sensor is interrupted or blocked.	Go to step 4.	Go to step 3.
3	Check the above sensor for proper connection. Is the above sensor connected properly?	Replace the Sensor (input). Go to " <b>Sensor (input) removal (T650, T652, T654)</b> " on page 4-71.	Replace the connection.
4	Perform a print test. Does the problem remain?	Contact next highest level of tech support.	Problem solved.

## Sensor (fuser output) late jam service check.

Use this procedure for the following jams:

- 201.02
- 201.07
- 201.27
- 201.32
- 201.50
- 201.52
- 201.57
- 201.75
- 201.77
- 201.82

Step	Check	Yes	No
1	Check the media size setup and tray guides for all media trays. Does the media size, in use, match the size set for all media trays?	Go to step 2.	Replace the media, or change the media size setup.
2	Check all the media trays for proper media installation. Is the media properly installed in all the media trays?	Go to step 3.	Remove and properly re-install the media.
3	Check the fuser unit assembly for damage and life expiration. Is the above component damaged or has it exceeded life?	Replace the fuser unit assembly. Go to " <b>Fuser unit assembly removal (T650, T652, T654)</b> " on page 4-23.	Go to step 4.
4	Check the fuser unit assembly for obstructions. Is the above component free from obstructions?	Go to step 5.	Remove obstructions.

Step	Check	Yes	No
5	Check the sensor (fuser output) for proper operation. 1. Enter the diagnostic mode 2. Select Base sensor tests 3. Observe the line item "output" Does the display on the operator panel, change every time the sensing area of the above sensor is interrupted or blocked.	Go to step 7.	Go to step 6.
6	Check the above sensor for proper connection. Is the above sensor connected properly?	Replace the fuser unit assembly. Go to " <b>Fuser unit assembly removal (T650, T652, T654)</b> " on page 4-23.	Replace the connection.
7	Check the aligner assembly for obstructions. Is the above component free from obstructions?	Go to step 8.	Remove obstructions.
8	Check the transfer roll assembly for damage. Is the above component free from damage?	Go to step 9.	Replace the transfer roll assembly. Go to " <b>Transfer roll assembly removal (T650, T652, T654)</b> " on page 4-78.
9	Perform a print test and check the main motor assembly. Is the media properly transported and able to reach the sensor (fuser output)?	Go to step 10.	Replace the main drive motor assembly. Go to " <b>Output cover assembly removal (T650, T652, T654)</b> " on page 4-54.
10	Perform a print test. Does the problem remain?	Contact next highest level of tech support.	Problem solved.

## Sensor (fuser output) lingering jam service check.

Use this procedure for the following jams:

- 202.01                      • 202.02                      • 202.07                      • 202.10                      • 202.11
- 202.12                      • 202.26                      • 202.27                      • 202.32                      • 202.34
- 202.35                      • 202.36                      • 202.37                      • 202.51                      • 202.52
- 202.57                      • 202.59                      • 202.60                      • 202.61                      • 202.62
- 202.76                      • 202.77                      • 202.82                      • 202.84                      • 202.85
- 202.86                      • 202.87

Step	Check	Yes	No
1	Check the media size setup and tray guides for all media trays. Does the media size, in use, match the size set for all media trays?	Go to step 2.	Replace the media, or change the media size setup.
2	Check all the media trays for proper media installation. Is the media properly installed in all the media trays?	Go to step 3.	Remove and properly re-install the media.
3	Check the door assembly, rear. Is the above component properly closed?	Go to step 4.	Open then properly close the door assembly, rear.
4	Check the fuser unit assembly for damage and life expiration. Is the above component damaged or has it exceeded life?	Replace the fuser unit assembly. Go to <b>“Fuser unit assembly removal (T650, T652, T654)” on page 4-23.</b>	Go to step 5.
5	Check the sensor (fuser output) for proper operation. 1. Enter the diagnostic mode 2. Select Base sensor tests 3. Observe the line item “output” Does the display on the operator panel, change every time the sensing area of the above sensor is interrupted or blocked.	Go to step 7.	Go to step 6.
6	Check the above sensor for proper connection. Is the above sensor connected properly?	Replace the fuser unit assembly. Go to <b>“Fuser unit assembly removal (T650, T652, T654)” on page 4-23.</b>	Replace the connection.
7	Check the redrive assembly for damage. Is the above component free from damage?	Go to step 8.	Replace the redrive assembly. Go to <b>“Option removals” on page 4-83.</b>

Step	Check	Yes	No
8	Perform a print test and check the redrive motor assembly for proper operation. Does the above component operate properly?	Go to step 9.	Replace the redrive motor assembly. Go to <b>“Redrive assembly removal (T650, T652, T654)” on page 4-62.</b>
9	Perform a print test. Does the problem remain?	Contact next highest level of tech support.	Problem solved.

### Sensor (fuser output) static jam service check

Use this procedure for the following jams:

- 202.06                      • 202.13                      • 202.31                      • 202.38                      • 202.56
- 202.63                      • 202.81                      • 202.88

Step	Check	Yes	No
1	Check the media path for partially fed or jammed media. Is the media path free from partially fed or jammed media?	Go to step 2.	Remove any pre-staged or jammed media.
2	Check the sensor (fuser output) for proper operation. 1. Enter the diagnostic mode 2. Select Base sensor test 3. Observe the line item “input” Does the display on the operator panel, change every time the sensing area of the above sensor is interrupted or blocked.	Go to step 4.	Go to step 3.
3	Check the above sensor for proper connection. Is the above sensor connected properly?	Replace the fuser unit assembly. Go to <b>“Fuser unit assembly removal (T650, T652, T654)” on page 4-23.</b>	Replace the connection.
4	Perform a print test. Does the problem remain?	Contact next highest level of tech support.	Problem solved.



## Sensor (narrow media) late jam service check.

Use this procedure for the following jams:

- 201.04                      • 201.06                      • 201.29                      • 201.31                      • 201.54
- 201.56                      • 201.79                      • 201.81

Step	Check	Yes	No
1	Check the media size setup and tray guides for all media trays. Does the media size, in use, match the size set for all media trays?	Go to step 2.	Replace the media, or change the media size setup.
2	Check all the media trays for proper media installation. Is the media properly installed in all the media trays?	Go to step 3.	Remove and properly re-install the media.
3	Check the fuser unit assembly for damage and life expiration. Is the above component damaged or has it exceeded life?	Replace the fuser unit assembly. Go to <b>“Fuser unit assembly removal (T650, T652, T654)” on page 4-23.</b>	Go to step 4.
4	Check the fuser unit assembly for obstructions. Is the above component free from obstructions?	Go to step 5.	Remove obstructions.
5	Check the sensor (narrow media) for proper operation. 1. Enter the diagnostic mode 2. Select Base sensor tests 3. Observe the line item “output” Does the display on the operator panel, change every time the sensing area of the above sensor is interrupted or blocked.	Go to step 7.	Go to step 6.
6	Check the above sensor for proper connection. Is the above sensor connected properly?	Replace the fuser unit assembly. Go to <b>“Fuser unit assembly removal (T650, T652, T654)” on page 4-23.</b>	Replace the connection.
7	Check the aligner assembly for obstructions. Is the above component free from obstructions?	Go to step 8.	Remove obstructions.
8	Check the transfer roll assembly for damage. Is the above component free from damage?	Go to step 9.	Replace the transfer roll assembly. Go to <b>“Transfer roll assembly removal (T650, T652, T654)” on page 4-78.</b>

Step	Check	Yes	No
9	Perform a print test and check the main motor assembly. Is the media properly transported and able to reach the sensor (fuser output)?	Go to step 10.	Replace the main drive motor assembly.  Go to <b>“Output cover assembly removal (T650, T652, T654)” on page 4-54.</b>
10	Perform a print test. Does the problem remain?	Contact next highest level of tech support.	Problem solved.

### Sensor (narrow media) static jam service check

Use this procedure for the following jams:

- 202.03                      • 202.13                      • 202.28                      • 202.38                      • 202.53
- 202.63                      • 202.78                      • 202.88

Step	Check	Yes	No
1	Check the media path for partially fed or jammed media. Is the media path free from partially fed or jammed media?	Go to step 2.	Remove any pre-staged or jammed media.
2	Check the sensor (narrow media) for proper operation. 1. Enter the diagnostic mode 2. Select Base sensor test 3. Observe the line item “input”  Does the display on the operator panel, change every time the sensing area of the above sensor is interrupted or blocked.	Go to step 4.	Go to step 3.
3	Check the above sensor for proper connection. Is the above sensor connected properly?	Replace the fuser unit assembly.  Go to <b>“Fuser unit assembly removal (T650, T652, T654)” on page 4-23.</b>	Replace the connection.
4	Perform a print test. Does the problem remain?	Contact next highest level of tech support.	Problem solved.

## Sensor (duplex input) late jam service check.

Use this procedure for the following jams:

- 230.02
- 231.00

Step	Check	Yes	No
1	Check the door assembly, rear. Is the above component properly closed?	Go to step 2.	Open then properly close the door assembly, rear.
2	Check the fuser access door. Is the above component properly closed?	Go to step 3.	Open then properly close the fuser access door.
3	Check media origination. Did the media originate from the internal duplex?	Go to step 4	Go to step 10
4	Check the internal duplex media path for obstructions. Is the above component free from obstructions?	Go to step 5	Remove obstructions.
5	Check the redrive assembly for damage. Is the above component free from damage?	Go to step 6	Replace the redrive assembly. Go to <b>“Option removals” on page 4-83.</b>
6	Perform a print test and check the redrive motor assembly for proper operation. Does the above component operate properly?	Go to step 7.	Replace the redrive motor assembly. Go to <b>“Redrive assembly removal (T650, T652, T654)” on page 4-62.</b>
7	Perform a print test and check the duplex drive motor assembly for proper operation. Does the above component operate properly?	Go to step 8	Replace the duplex drive motor assembly. Go to <b>“Duplex drive motor assembly removal (T652, T654)” on page 4-19.</b>
8	Check the sensor (duplex input) for proper operation. 1. Enter the diagnostic mode 2. Select Duplex tests 3. Select sensor test 4. Observe the line item “input” Does the display on the operator panel, change every time the sensing area of the above sensor is interrupted or blocked.	Go to step 10.	Go to step 9.

Step	Check	Yes	No
9	Check the above sensor for proper connection. Is the above sensor connected properly?	Replace the Sensor (duplex input).  Go to <b>“Sensor (duplex input) removal (T652, T654)” on page 4-68.</b>	Replace the connection.
10	Perform a print test and check the duplex drive motor assembly for proper operation. Does the above component operate properly?	Go to step 14.	Replace the duplex drive motor assembly.  Go to <b>“Duplex drive motor assembly removal (T652, T654)” on page 4-19.</b>
11	Check the external duplex media path for obstructions. Is the above component free from obstructions?	Go to step 12	Remove obstructions.
12	Check the external duplex unit assembly for proper installation. Is the above component properly installed?	Go to step 13.	Remove then properly re-install the external duplex unit assembly.
13	Check the sensor (duplex input) for proper operation. 1. Enter the diagnostic mode 2. Select Duplex tests 3. Select sensor test 3. Observe the line item “input”  Does the display on the operator panel, change every time the sensing area of the above sensor is interrupted or blocked.	Go to step 14.	Replace the external duplex assembly.
14	Perform a print test using the duplex. Does the problem remain?	Contact next highest level of tech support.	Problem solved.

### Sensor (duplex input) lingering jam service check.

Use this procedure for the following jams:

- 230.01
- 230.05
- 232.00

Step	Check	Yes	No
1	Check media origination. Did the media originate from the internal duplex?	Go to step 2	Go to step 7
2	Check the internal duplex media path for obstructions. Is the above component free from obstructions?	Go to step 3	Remove obstructions.

Step	Check	Yes	No
3	Check the duplex guide assembly, front for damage. Is the above component free from damage?	Go to step 4.	Replace the duplex guide assembly, front. Go to <b>“Duplex guide assembly, front removal (T652, T654)” on page 4-21.</b>
4	Check the sensor (duplex input) for proper operation. 1. Enter the diagnostic mode 2. Select Duplex tests 3. Select sensor test 4. Observe the line item “input” Does the display on the operator panel, change every time the sensing area of the above sensor is interrupted or blocked.	Go to step 6.	Go to step 5.
5	Check the above sensor for proper connection. Is the above sensor connected properly?	Replace the sensor (duplex input). Go to <b>“Sensor (duplex input) removal (T652, T654)” on page 4-68.</b>	Replace the connection.
6	Check the aligner assembly for obstructions. Is the above component free from obstructions?	Go to step 7.	Remove obstructions.
7	Check the external duplex media path for obstructions. Is the above component free from obstructions?	Go to step x	Remove obstructions.
8	Check the external duplex unit assembly for proper installation. Is the above component properly installed?	Go to step 9.	Remove then properly re-install the external duplex unit assembly.
9	Check the sensor (duplex input) for proper operation. 1. Enter the diagnostic mode 2. Select Duplex tests 3. Select sensor test 3. Observe the line item “input” Does the display on the operator panel, change every time the sensing area of the above sensor is interrupted or blocked.	Go to step 10.	Replace the external duplex assembly.
10	Perform a print test using the duplex. Does the problem remain?	Contact next highest level of tech support.	Problem solved.

## Sensor (duplex input) static jam service check.

Use this procedure for the following jams:

- 230.13
- 238.01
- 238.03
- 238.05
- 238.07

Step	Check	Yes	No
1	Check media origination. Did the media originate from the internal duplex?	Go to step 2	Go to step 5
2	Check the media path for partially fed or jammed media. Is the media path free from partially fed or jammed media?	Go to step 3.	Remove any pre-staged or jammed media.
3	Check the sensor (duplex input) for proper operation. 1. Enter the diagnostic mode 2. Select Duplex tests 3. Select sensor test 4. Observe the line item "input"  Does the display on the operator panel, change every time the sensing area of the above sensor is interrupted or blocked.	Go to step 7.	Go to step 4.
4	Check the above sensor for proper connection. Is the above sensor connected properly?	Replace the sensor (duplex input).  Go to " <b>Sensor (duplex input) removal (T652, T654)</b> " on page 4-68.	Replace the connection.
5	Check the media path for partially fed or jammed media. Is the media path free from partially fed or jammed media?	Go to step 6.	Remove any pre-staged or jammed media.
6	Check the sensor (duplex input) for proper operation. 1. Enter the diagnostic mode 2. Select Duplex tests 3. Select sensor test 3. Observe the line item "input"  Does the display on the operator panel, change every time the sensing area of the above sensor is interrupted or blocked.	Go to step 7.	Replace the external duplex assembly.
7	Perform a print test using the duplex. Does the problem remain?	Contact next highest level of tech support.	Problem solved.

## Sensor (pass through) late jam service check

Use this procedure for the following jams:

- 242.02                      • 242.03                      • 242.04                      • 242.05                      • 242.06
- 242.10                      • 242.16                      • 242.37                      • 243.02                      • 243.03
- 243.04                      • 243.04                      • 243.05                      • 243.06                      • 243.10
- 243.16                      • 243.37                      • 244.02                      • 244.03                      • 244.04
- 244.05                      • 244.06                      • 244.10                      • 244.16                      • 244.37
- 245.02                      • 245.03                      • 245.04                      • 245.05                      • 245.06
- 245.10                      • 245.13                      • 245.16                      • 245.37

Step	Check	Yes	No
1	Check the media size setup and tray guides for all media trays. Does the media size, in use, match the size set for all media trays?	Go to step 2.	Replace the media, or change the media size setup.
2	Check the media trays for overfilling. Are any of the media trays overfilled?	Remove any excess new media.	Go to step 3
3	Check the media condition in all media trays. Is any of the media in any of the media trays crumpled or damaged?	Replace the damaged media with new.	Go to step 4.
4	Check the media tray pass through areas for obstructions. Are the pass through areas in all the media trays free from obstructions?	Go to step 5.	Remove obstructions.
5	Check the two pick roll assemblies in the media tray being picked from. Are the above components free of excess wear and contamination?	Go to step 6.	Clean or replace the pick roll assembly. Go to <b>“Pick roll assembly removal (T650, T652, T654)” on page 4-57</b>
6	Check the appropriate media tray sensor (pass through) for proper operation. 1. Enter the diagnostic mode 2. Select Input tray tests 3. Sensor test 4. Select the appropriate tray number 3. Observe the line item “pass through” for the appropriate media tray Does the display on the operator panel, change every time the sensing area of the above sensor is interrupted or blocked.	Go to step 7.	Go to step 6.

Step	Check	Yes	No
7	Check the above sensor for proper connection. Is the above sensor connected properly?	Replace the appropriate Sensor (pass through).  Go to <b>“250-sheet controller card assembly removal” on page 4-106.</b>	Replace the connection.
8	Perform a print test and check the pick arm assembly for the appropriate media tray. Is the media properly picked and advanced out of the appropriate media tray?	Go to step 8.	Replace the appropriate pick arm assembly.  Go to <b>“Operator panel door assembly removal (models X651, X652, X654, and X656)” on page 4-49.</b>
9	Perform a print test and check the main motor assembly. Is the media properly transported through the pass through areas of the media trays?	Go to step 9.	Replace the main drive motor assembly.  Go to <b>“Output cover assembly removal (T650, T652, T654)” on page 4-54.</b>
10	Perform a print test using the appropriate input tray. Does the error continue?	Replace the input option.	Problem solved.

### Sensor (pass through) lingering jam service check.

Use this procedure for the following jams:

- 242.08                      • 242.40                      • 243.08                      • 243.40                      244.08
- 244.40                      • 245.08                      • 245.40

Step	Check	Yes	No
1	Check the media size setup and tray guides for all media trays. Does the media size, in use, match the size set for all media trays?	Go to step 2.	Replace the media, or change the media size setup.
2	Check the media tray pass through areas for obstructions. Are the pass through areas in all the media trays free from obstructions?	Go to step 3.	Remove obstructions.



Step	Check	Yes	No
<b>3</b>	Check the appropriate media tray sensor (pass through) for proper operation. 1. Enter the diagnostic mode 2. Select Input tray tests 3. Sensor test 4. Select the appropriate tray number 3. Observe the line item "pass through" for the appropriate media tray Does the display on the operator panel, change every time the sensing area of the above sensor is interrupted or blocked.	Go to step 5.	Go to step 4.
<b>4</b>	Check the above sensor for proper connection. Is the above sensor connected properly?	Replace the appropriate Sensor (pass through). Go to <b>"250-sheet controller card assembly removal"</b> on page 4-106.	Replace the connection.
<b>5</b>	Perform a print test and check the main motor assembly. Is the media properly transported through the pass through areas of the media trays?	Replace the main drive motor assembly. Go to <b>"Output cover assembly removal (T650, T652, T654)"</b> on page 4-54.	Replace the connection.
<b>6</b>	Perform a print test using the appropriate input tray. Does the error continue?	Replace the input option.	Problem solved.

### Sensor (pass through) static jam service check

Use this procedure for the following jams:

- 242.13                      • 242.36                      • 243.13                      • 243.36                      244.13
- 244.36                      • 245.13                      • 245.36

Step	Check	Yes	No
<b>1</b>	Check the media path for partially fed or jammed media. Is the media path free from partially fed or jammed media?	Go to step 2.	Remove any pre-staged or jammed media.

Step	Check	Yes	No
2	<p>Check the appropriate media tray sensor (pass through) for proper operation.</p> <ol style="list-style-type: none"> <li>1. Enter the diagnostic mode</li> <li>2. Select Input tray tests</li> <li>3. Sensor test</li> <li>4. Select the appropriate tray number</li> </ol> <p>3. Observe the line item "pass through" for the appropriate media tray</p> <p>Does the display on the operator panel, change every time the sensing area of the above sensor is interrupted or blocked.</p>	Go to step 5.	Go to step 4.
3	<p>Check the above sensor for proper connection.</p> <p>Is the above sensor connected properly?</p>	<p>Replace the appropriate sensor (pass through).</p> <p>Go to <b>"250-sheet controller card assembly removal"</b> on page 4-106.</p>	Replace the connection.
4	<p>Perform a print test using the appropriate input tray.</p> <p>Does the error continue?</p>	Replace the input option.	Problem solved.

### Sensor (stapler pass through) late jam service check

Step	Check	Yes	No
1	<p>Check the output option for proper installation.</p> <p>Is the above component properly installed?</p>	Go to step 2.	Remove then reinstall the output option
2	<p>Check for obstructions in the media path between the base machine and the output option.</p> <p>Is the media path free from obstructions?</p>	Go to step 3.	Remove obstructions.
3	<p>Check the sensor (stapler pass through) for proper operation.</p> <ol style="list-style-type: none"> <li>1. Enter the diagnostic mode</li> <li>2. Select Finisher sensor test</li> <li>3. Select Sensor test</li> <li>4. Select pass &amp; media</li> <li>5. Observe the line item "passthru"</li> </ol> <p>Does the display on the operator panel, change every time the sensing area of the above sensor is interrupted or blocked.</p>	Go to step 5.	Go to step 4.
4	<p>Check the above sensor for proper connection.</p> <p>Is the above sensor connected properly?</p>	<p>Replace the stapler unit assembly.</p> <p>Go to <b>"SFP stapler assembly stapler unit assembly removal"</b> on page 4-182.</p>	Replace the connection.

Step	Check	Yes	No
5	Perform a print test using the output option. Does the error continue?	Replace the output option.	Problem solved.

### Sensor (stapler pass through) lingering jam service check

Step	Check	Yes	No
1	Check the output option for proper installation. Is the above component properly installed?	Go to step 2.	Remove then reinstall the output option
2	Check for obstructions in the media path between the Sensor (stapler pass through) machine and the media bin. Is the media path free from obstructions?	Go to step 3.	Remove obstructions.
3	Check the sensor (stapler pass through) for proper operation. 1. Enter the diagnostic mode 2. Select Finisher sensor test 3. Select Sensor test 4. Select pass & media 5. Observe the line item "passthru" Does the display on the operator panel, change every time the sensing area of the above sensor is interrupted or blocked.	Go to step 5.	Go to step 4.
4	Check the above sensor for proper connection. Is the above sensor connected properly?	Replace the stapler unit assembly.  Go to " <b>SFP stapler assembly stapler unit assembly removal</b> " on page 4-182.	Replace the connection.
5	Perform a print test using the output option. Does the error continue?	Replace the output option.	Problem solved.

### Sensor (stapler pass through) static jam service check

Step	Check	Yes	No
1	Check the media path for partially fed or jammed media. Is the media path free from partially fed or jammed media?	Go to step 2.	Remove any pre-staged or jammed media.

Step	Check	Yes	No
<b>2</b>	<p>Check the sensor (stapler pass through) for proper operation.</p> <ol style="list-style-type: none"> <li>1. Enter the diagnostic mode</li> <li>2. Select Finisher sensor test</li> <li>3. Select Sensor test</li> <li>4. Select pass &amp; media</li> <li>5. Observe the line item "passthru"</li> </ol> <p>Does the display on the operator panel, change every time the sensing area of the above sensor is interrupted or blocked.</p>	Go to step 4.	Go to step 3.
<b>3</b>	<p>Check the above sensor for proper connection. Is the above sensor connected properly?</p>	<p>Replace the stapler unit assembly.</p> <p>Go to <b>"SFP stapler assembly stapler unit assembly removal" on page 4-182.</b></p>	Replace the connection.
<b>4</b>	<p>Perform a print test using the output option. Does the error continue?</p>	Replace the output option.	Problem solved.

### Sensor (output pass through) late jam service check

Step	Check	Yes	No
<b>1</b>	<p>Check the output option for proper installation. Is the above component properly installed?</p>	Go to step 2.	Remove then reinstall the output option
<b>2</b>	<p>Check for obstructions in the media path between the base machine and the output option. Is the media path free from obstructions?</p>	Go to step 3.	Remove obstructions.
<b>3</b>	<p>Check the sensor (output pass through) for proper operation.</p> <ol style="list-style-type: none"> <li>1. Enter the diagnostic mode</li> <li>2. Select Output bin tests</li> <li>3. Select Sensor test</li> <li>4. Select Output bin x</li> <li>5. Observe the line item "passthru"</li> </ol> <p>Does the display on the operator panel, change every time the sensing area of the above sensor is interrupted or blocked.</p>	Go to step 5.	Go to step 4.

Step	Check	Yes	No
4	Check the above sensor for proper connection. Is the above sensor connected properly?	Replace the sensor (output pass through).  Go to <b>“High capacity stacker sensor (pass through) removal” on page 4-144.</b>  Go to <b>“5-bin mailbox sensor (pass through) removal” on page 4-90.</b>  Go to <b>“Output expander sensor (pass through) removal” on page 4-169.</b>	Replace the connection.
5	Perform a print test using the output option. Does the error continue?	Replace the output option.	Problem solved.

### Sensor (output pass through) lingering jam service check

Step	Check	Yes	No
1	Check the output option for proper installation. Is the above component properly installed?	Go to step 2.	Remove then reinstall the output option
2	Check for obstructions in the media path between the Sensor (output pass through) machine and the media bin. Is the media path free from obstructions?	Go to step 3.	Remove obstructions.
3	Check the sensor (output pass through) for proper operation. 1. Enter the diagnostic mode 2. Select Output bin tests 3. Select Sensor test 4. Select Output bin x 5. Observe the line item “passthru”  Does the display on the operator panel, change every time the sensing area of the above sensor is interrupted or blocked.	Go to step 5.	Go to step 4.

Step	Check	Yes	No
4	Check the above sensor for proper connection. Is the above sensor connected properly?	Replace the sensor (output pass through).  Go to “ <b>High capacity stacker sensor (pass through) removal</b> ” on page 4-144.  Go to “ <b>5-bin mailbox sensor (pass through) removal</b> ” on page 4-90.  Go to “ <b>Output expander sensor (pass through) removal</b> ” on page 4-169.	Replace the connection.
5	Perform a print test using the output option. Does the error continue?	Replace the output option.	Problem solved.

### Sensor (output pass through) static jam service check

Step	Check	Yes	No
1	Check the media path for partially fed or jammed media. Is the media path free from partially fed or jammed media?	Go to step 2.	Remove any pre-staged or jammed media.
2	Check the sensor (output pass through) for proper operation.  1. Enter the diagnostic mode 2. Select Output bin tests 3. Select Sensor test 4. Select Output bin x 5. Observe the line item “passthru”  Does the display on the operator panel, change every time the sensing area of the above sensor is interrupted or blocked.	Go to step 4.	Go to step 3.

Step	Check	Yes	No
3	Check the above sensor for proper connection. Is the above sensor connected properly?	Replace the sensor (output pass through).  Go to <b>“High capacity stacker sensor (pass through) removal” on page 4-144.</b>  Go to <b>“5-bin mailbox sensor (pass through) removal” on page 4-90.</b>  Go to <b>“Output expander sensor (pass through) removal” on page 4-169.</b>	Replace the connection.
4	Perform a print test using the output option. Does the error continue?	Replace the output option.	Problem solved.

### Sensor (mailbox empty) late jam service check

Step	Check	Yes	No
1	Check the output option for proper installation. Is the above component properly installed?	Go to step 2.	Remove then reinstall the output option
2	Check for obstructions in the media path between the base machine and the output option. Is the media path free from obstructions?	Go to step 3.	Remove obstructions.
3	Check the sensor (mailbox empty) for proper operation. 1. Enter the diagnostic mode 2. Select Output bin tests 3. Select Sensor test 4. Select Output bin x 5. Observe the line item “mailbox empty” Does the display on the operator panel, change every time the sensing area of the above sensor is interrupted or blocked.	Go to step 5.	Go to step 4.
4	Check the above sensor for proper connection. Is the above sensor connected properly?	Replace the sensor (mailbox empty).  Go to <b>“5-bin mailbox sensor (media bin empty) removal” on page 4-91.</b>	Replace the connection.
5	Perform a print test using the output option. Does the error continue?	Replace the output option.	Problem solved.

### Sensor (mailbox empty) lingering jam service check

Step	Check	Yes	No
1	Check the output option for proper installation. Is the above component properly installed?	Go to step 2.	Remove then reinstall the output option
2	Check for obstructions in the media path between the Sensor (mailbox empty) machine and the media bin. Is the media path free from obstructions?	Go to step 3.	Remove obstructions.
3	Check the sensor (mailbox empty) for proper operation. 1. Enter the diagnostic mode 2. Select Output bin tests 3. Select Sensor test 4. Select Output bin x 5. Observe the line item "mailbox empty" Does the display on the operator panel, change every time the sensing area of the above sensor is interrupted or blocked.	Go to step 5.	Go to step 4.
4	Check the above sensor for proper connection. Is the above sensor connected properly?	Replace the sensor (mailbox empty).  Go to " <b>5-bin mailbox sensor (media bin empty) removal</b> " on page 4-91.	Replace the connection.
5	Perform a print test using the output option. Does the error continue?	Replace the output option.	Problem solved.

### Sensor (mailbox empty) static jam service check

Step	Check	Yes	No
1	Check the media path for partially fed or jammed media. Is the media path free from partially fed or jammed media?	Go to step 2.	Remove any pre-staged or jammed media.
2	Check the sensor (mailbox empty) for proper operation. 1. Enter the diagnostic mode 2. Select Output bin tests 3. Select Sensor test 4. Select Output bin x 5. Observe the line item "passthru" Does the display on the operator panel, change every time the sensing area of the above sensor is interrupted or blocked.	Go to step 4.	Go to step 3.



Step	Check	Yes	No
3	Check the above sensor for proper connection. Is the above sensor connected properly?	Replace the sensor (mailbox empty). Go to <b>“5-bin mailbox sensor (media bin empty) removal” on page 4-91.</b>	Replace the connection.
4	Perform a print test using the output option. Does the error continue?	Replace the output option.	Problem solved.

### Sensor (toner empty) service check

Step	Check	Yes	No
1	Check the sensor (toner empty) for proper installation. Is the above component properly installed?	go to step 2.	Reinstall the sensor (toner empty)
2	Check the sensor (toner empty) for proper operation. 1. Enter the diagnostic mode 2. Select Base sensor test 3. Observe the line item “toner” Does the display on the operator panel, change every time the sensing area of the above sensor is interrupted or blocked?	The sensor is working properly.	Go to step 3.
3	Check the above sensor for proper connection. Is the above sensor connected properly?	Replace the sensor (toner empty). Go to <b>“Sensor (toner empty) removal (T650, T652, T654)” on page 4-71.</b>	Replace the connection.

### NVRAM mismatch failure (950.00 through 950.29) service check

<p><b>Warning:</b> When replacing any of the following components:</p> <ul style="list-style-type: none"> <li>• Operator panel assembly</li> <li>• System card assembly</li> </ul> <p>Only replace one component at a time. replace the required component and perform a POR before replacing a second component listed above. If this procedure is not followed, the printer will be rendered inoperable. Never replace two or more of the components listed above without a POR after installing each one or the printer will be rendered inoperable.</p> <p><b>Warning:</b> These components can be used as a method of troubleshooting as long as the machine is booted into diagnostic mode or is operating in diagnostic mode. Once a component has been installed in a machine and powered up into user mode, it cannot be used in another machine. It must be returned to the manufacturer.</p>			
Step	Check	Yes	No
1	Check the operator panel assembly. Was the operator panel assembly recently replaced?	Go to step 3.	Go to step 2.

2	Check the system card assembly. Was the system card assembly recently replaced?	Go to step 4.	Contact next level of support.
3	Replace the current operator panel assembly with the original operator panel assembly. Does the error remain?	Go to step 5.	Problem solved.
4	Replace the current system card assembly with the original system card assembly. Go to <b>“System card assembly removal (T650, T652, T654, T656)” on page 4-76.</b>	Go to step 6.	Problem solved.
5	If problem continues, replace the original operator panel assembly with a new and not previously installed operator panel assembly. Does the error continue?	Contact the next level of support.	Problem solved.
6	If the problem continues, replace the original panel assembly with a new and not previously installed operator panel door assembly. Go to <b>“Operator panel door assembly removal (T650, T652, T654)” on page 4-44.</b>	Contact the next level of support.	Problem solved.

---

## Image quality trouble

### Printer Related Troubleshooting

**Note:** First, get a printout as a base, and follow the symptom table to identify the possible failing FRU's.

#### Image quality symptoms

- Faint print (low contrast)— **“Faint print (Low contrast)” on page 2-158.**
- Blank print (no print)— **“Blank print (no print)” on page 2-160.**
- Solid black— **“Solid black” on page 2-162.**
- Vertical blank lines (White stripes in media transport direction)— **“Vertical lines and bands (process direction)” on page 2-163.**
- Horizontal band—**“Horizontal white stripes or bands (side to side direction)” on page 2-164**
- Vertical stripes— **“Vertical stripes (process direction)” on page 2-165.**
- Horizontal stripes— **“Horizontal stripes (side to side direction)” on page 2-166.**
- Partial lack— **“Partial lack” on page 2-168.**
- Spots— **“Spots” on page 2-169.**
- Afterimage— **“After image” on page 2-171.**
- Background (fog)— **“Background (fog)” on page 2-172.**
- Skew—**“Skew” on page 2-173.**
- Media damage— **“Media damage” on page 2-174.**
- No fuse—**“No fuse” on page 2-176.**

**Note:** When horizontal lines and/or spots occur periodically, it is possibly caused by a particular roll. In this case, measure the interval on the print test, and check the relation to the roll in the printer. The interval does not necessarily match circumference of the roll.

## Image Quality

### Faint print (Low contrast)



Before starting, check the media route for foreign objects, such as staples, clips, and scraps, in the media path.

Step	Check	Yes	No
1	Check the media condition. Load new, dry, recommended media, and perform a print test. Is the image density normal?	Problem solved.	Go to step 2.
2	Check the toner level. Is the toner level normal?	Go to step 3.	Replace the print cartridge.
3	Check the transfer roll assembly for contamination and wear. Is the above component free of excess wear and contamination?	Go to step 4.	Replace the transfer roll assembly. Go to <b>“Transfer roll assembly removal (T650, T652, T654)” on page 4-78.</b>
4	Check the print cartridge for proper installation. Is the print cartridge properly installed?	Go to step 5.	Inspect, clean and reinstall replace the print cartridge.
5	Check the laser beam route. Check for debris between the printhead assembly and the PC drum. Is the laser beam route free of debris and the glass window, in the printhead assembly, free of contamination?	Go to step 6.	Remove debris or clean the printhead assembly window.
6	Check the HVPS card assembly for proper connection. Is the above component properly connected?	Replace the HVPS card assembly. Go to <b>“HVPS card assembly removal (T650, T652, T654)” on page 4-24.</b>	Replace the connections.

Step	Check	Yes	No
7	Check the printhead assembly for proper connection. Is the above component properly connected?	Replace the printhead assembly.  Go to <b>“Printhead assembly removal (T650)” on page 4-60</b> or <b>“Printhead assembly removal (T652, T654)” on page 4-61.</b>	Replace the connections.
8	Perform a print test. Does the problem remain?	Contact next highest level of tech support.	Problem solved.

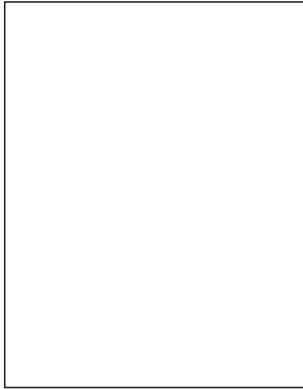
**Blank print (no print)**

Check the media path for foreign objects such as staples, clips, scraps of media.

Step	Check	Yes	No
1	Check the media condition. Load new, dry, recommended media, and perform a print test. Is the image density normal?	Problem solved.	Go to step 2.
2	Check the toner level. Is the toner level normal?	Go to step 3.	Replace the print cartridge.
3	Check the transfer roll assembly for proper installation? Is the above component properly installed?	Go to step 4.	Reinstall the transfer roll assembly.
4	Check the left and right transfer roll bracket. Are the above components free from damage?	Go to step 5.	Replace the left and or right transfer roll brackets.  Go to <b>“Printhead assembly removal (T650)” on page 4-60</b> or <b>“Printhead assembly removal (T652, T654)” on page 4-61.</b>
5	Check the transfer roll assembly for contamination and wear. Is the above component free of excess wear and contamination?	Go to step 6.	Replace the transfer roll assembly.  Go to <b>“Transfer roll assembly removal (T650, T652, T654)” on page 4-78.</b>
6	Check the print cartridge for proper installation. Is the print cartridge properly installed?	Go to step 7.	Inspect, clean and reinstall replace the print cartridge.

Step	Check	Yes	No
7	<p>Check the laser beam route.</p> <p>Check for debris between the printhead assembly and the PC drum.</p> <p>Is the laser beam route free of debris and the glass window, in the printhead assembly, free of contamination?</p>	Go to step 8.	Remove debris or clean the printhead assembly window.
8	<p>Check the HVPS card assembly for proper connection.</p> <p>Is the above component properly connected?</p>	<p>Replace the HVPS card assembly.</p> <p>Go to <b>“HVPS card assembly removal (T650, T652, T654)” on page 4-24.</b></p>	Replace the connections.
9	<p>Check the printhead assembly for proper connection.</p> <p>Is the above component properly connected?</p>	<p>Replace the printhead assembly.</p> <p>Go to <b>“Printhead assembly removal (T650)” on page 4-60</b> or <b>“Printhead assembly removal (T652, T654)” on page 4-61.</b></p>	Replace the connections.
10	<p>Check the system card assembly for proper connection.</p> <p>Is the above component properly connected?</p>	<p>Replace the system card assembly.</p> <p>Go to <b>“System card assembly removal (T650, T652, T654, T656)” on page 4-76.</b></p>	Replace the connections.

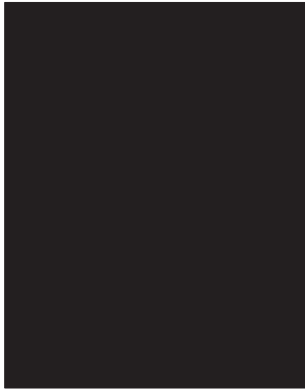
**Solid black**

Check the media path for foreign objects such as staples, clips, scraps of media.

<b>Step</b>	<b>Check</b>	<b>Yes</b>	<b>No</b>
<b>1</b>	Check the charge roll assembly for proper installation. Is the above component properly installed?	Go to step 2.	Replace the charge roll assembly.
<b>2</b>	Check the print cartridge for proper installation. Is the above component properly installed?	Go to step 3.	Inspect, clean and reinstall replace the print cartridge.
<b>3</b>	Check the charge roll HVPS card assembly connections Is the above component properly connected?	Replace the HVPS card assembly. Go to <b>“HVPS card assembly removal (T650, T652, T654)” on page 4-24.</b>	Replace the connection.
<b>4</b>	Check the system card assembly for proper connection. Is the above component properly connected?	Replace the system card assembly. Go to <b>“System card assembly removal (T650, T652, T654, T656)” on page 4-76.</b>	Replace the connections.



### Vertical lines and bands (process direction)

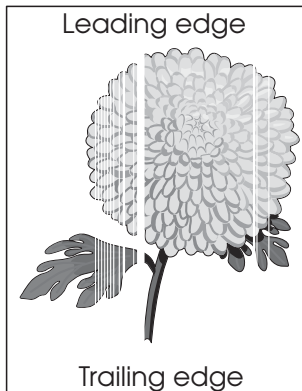

Step	Check	Yes	No
1	Check the media condition. Load new, dry, recommended media. Re-print the defective image. Does the error continue?	Go to step 2.	Problem solved.
2	Is the media transfer route and the media path clear of debris?	Go to step 3.	Remove debris or contamination.
3	Check the laser beam route. Check for debris between the printhead assembly and the PC drum. Is the laser beam route free of debris and the glass window, in the printhead assembly, free of contamination?	Go to step 4.	Remove debris or clean the printhead assembly window.
4	Check the print cartridge for proper installation. Is the above component properly installed?	Go to step 5.	Inspect, clean and reinstall replace the print cartridge.
5	Check the transfer roll assembly for contamination and wear. Is the above component free of excess wear and contamination?	Go to step 6.	Replace the transfer roll assembly. Go to <b>“Transfer roll assembly removal (T650, T652, T654)” on page 4-78.</b>
6	Check the printhead assembly for proper connection. Is the above component properly connected?	Replace the printhead assembly. Go to <b>“Printhead assembly removal (T650)” on page 4-60</b> or <b>“Printhead assembly removal (T652, T654)” on page 4-61.</b>	Replace the connections.

Step	Check	Yes	No
7	Perform a print test. Does the problem remain?	Contact next highest level of tech support.	Problem solved.

**Horizontal white stripes or bands (side to side direction)**

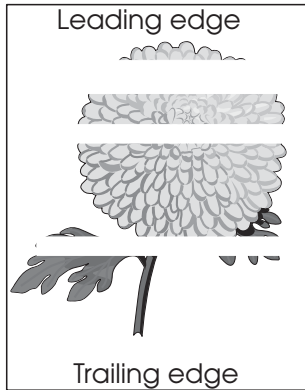

Step	Check	Yes	No
1	Check the media condition. Load new, dry, and recommended media. Re-print the defective image. Does the error continue?	Go to step 2.	Problem solved.
2	Are the media transfer route and the media path free of contamination and debris?	Go to step 3.	Remove debris or contamination.
3	Check the toner level. Is the toner level normal?	Go to step 4.	Replace the print cartridge.
4	Check the transfer roll assembly for contamination and wear. Is the above component free of excess wear and contamination?	Go to step 5.	Replace the transfer roll assembly. Go to <b>“Transfer roll assembly removal (T650, T652, T654)” on page 4-78.</b>
5	Check the printhead assembly for proper connection. Is the above component properly connected?	Replace the printhead assembly. Go to <b>“Printhead assembly removal (T650)” on page 4-60</b> or <b>“Printhead assembly removal (T652, T654)” on page 4-61.</b>	Replace the connections.

Step	Check	Yes	No
6	Perform a print test. Does the problem remain?	Contact next highest level of tech support.	Problem solved.

### Vertical stripes (process direction)

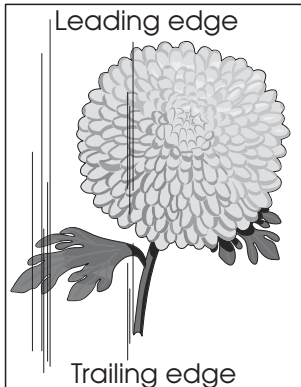

Step	Check	Yes	No
1	Check the media condition. Load new, dry, recommended media. Re-print the defective image. Does the error continue?	Go to step 2.	Problem solved.
2	Are the media transfer route and the media path free of contamination or debris?	Go to step 3.	Remove debris or contamination.
3	Check the charge roll assembly for contamination and wear. Is the above component free of excess wear and contamination?	Go to step 4.	Replace the charge roll assembly. Go to <b>“Access door removal (T650, T652, T654)”</b> on page 4-8.
4	Check the transfer roll assembly for contamination and wear. Is the above component free of excess wear and contamination?	Go to step 5.	Replace the transfer roll assembly. Go to <b>“Transfer roll assembly removal (T650, T652, T654)”</b> on page 4-78.
5	Check the print cartridge for proper installation. Is the above component properly installed?	Go to step 6.	Inspect, clean and reinstall replace the print cartridge.

Step	Check	Yes	No
6	<p>Check the heat roll and pressure roll. Remove the fuser unit assembly.</p> <div style="text-align: center;">  <p><b>CAUTION:</b> : Allow the fuser unit assembly to cool down.</p> </div> <p>Is there contamination or cracks on the heat roll and/or pressure roll?</p>	<p>Replace the fuser unit assembly. Go to <b>“Fuser unit assembly removal (T650, T652, T654)” on page 4-23.</b></p>	Go to step 7.
7	<p>Perform a print test. Does the problem remain?</p>	Contact next highest level of tech support.	Problem solved.

**Horizontal stripes (side to side direction)**

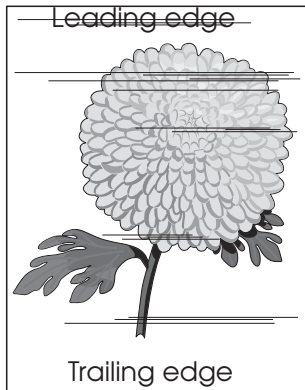

Step	Check	Yes	No
1	<p>Check the media condition. Load new, dry, recommended media. Re-print the defective image. Does the error continue?</p>	Go to step 2.	Problem solved.
2	<p>Check the media transfer route. Check the media route for contamination or obstacles.</p>	Go to step 3.	Remove obstacles or contamination.
3	<p>Check the print cartridge for proper installation. Is the above component properly installed?</p>	Go to step 4.	Inspect, clean and reinstall replace the print cartridge.

Step	Check	Yes	No
4	Check the charge roll assembly for contamination and wear. Is the above component free of excess wear and contamination?	Go to step 5.	Replace the charge roll assembly. Go to <b>“Access door removal (T650, T652, T654)” on page 4-8.</b>
5	Check the transfer roll assembly for contamination and wear. Is the above component free of excess wear and contamination?	Go to step 6.	Replace the transfer roll assembly. Go to <b>“Transfer roll assembly removal (T650, T652, T654)” on page 4-78.</b>
6	Check the heat roll and pressure roll. Remove the fuser unit assembly. <div style="text-align: center;">  </div> <b>CAUTION:</b> : Allow the fuser unit assembly to cool down.  Is there contamination or cracks on the heat roll and/or pressure roll?	Replace the fuser unit assembly. Go to <b>“Fuser unit assembly removal (T650, T652, T654)” on page 4-23.</b>	Go to step 7.
7	Check the HVPS card assembly for proper connection. Is the above component properly connected?	Replace the HVPS card assembly. Go to <b>“HVPS card assembly removal (T650, T652, T654)” on page 4-24.</b>	Replace the connections.
8	Perform a print test. Does the problem remain?	Contact next highest level of tech support.	Problem solved.

### Partial lack

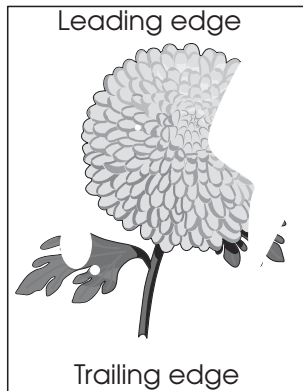

Step	Check	Yes	No
1	Check the media condition. Load new, dry, recommended media. Re-print the defective image. Does the problem remain?	Go to step 2.	Problem solved.
2	Check the toner level. Is the toner level normal?	Go to step 3.	Replace the print cartridge.
3	Check the laser beam route. Check for debris between the printhead assembly and the PC drum. Is the laser beam route free of debris and the glass window, in the printhead assembly, free of contamination?	Go to step 4.	Remove debris or clean the printhead assembly window.
4	Check the transfer roll assembly for contamination and wear. Is the above component free of excess wear and contamination?	Go to step 5.	Replace the transfer roll assembly. Go to <b>“Transfer roll assembly removal (T650, T652, T654)” on page 4-78.</b>
5	Check the printhead installation. Is the above component properly installed?	Go to step 6.	Reinstall and adjust the printhead assembly. Go to <b>“Printhead assembly removal (T650)” on page 4-60 or “Printhead assembly removal (T652, T654)” on page 4-61.</b>

Step	Check	Yes	No
6	Perform a print test. Does the problem remain?	Contact next highest level of tech support.	Problem solved.

### Spots



Step	Check	Yes	No
1	Check the media condition. Load new, dry, recommended media. Re-print the defective image. Does the error continue?	Go to step 2.	Problem solved.
2	Check the media transfer route. Is the media route free of contamination or debris?	Go to step 3.	Remove debris or contamination.
3	Check the print cartridge for spots or other damage on the drum surfaces. Is the print cartridges free of excess wear and contamination?	Go to step 4.	Replace the print cartridge.
4	Check the charge roll assembly for contamination and wear. Is the above component free of excess wear and contamination?	Go to step 5.	Replace the charge roll assembly. Go to <b>“Access door removal (T650, T652, T654)” on page 4-8.</b>
5	Check the transfer roll assembly for contamination and wear. Is the above component free of excess wear and contamination?	Go to step 6.	Replace the transfer roll assembly. Go to <b>“Transfer roll assembly removal (T650, T652, T654)” on page 4-78.</b>

Step	Check	Yes	No
6	<p>Check the heat roll and pressure roll. Remove the fuser unit assembly.</p>  <p><b>CAUTION:</b> : Allow the fuser unit assembly to cool down.</p> <p>Is there contamination or cracks on the heat roll and/or pressure roll?</p>	<p>Replace the fuser unit assembly. Go to <b>“Fuser unit assembly removal (T650, T652, T654)” on page 4-23.</b></p>	<p>Go to step 7</p>
7	<p>Check the printhead installation. Is the above component properly installed?</p>	<p>Go to step 8.</p>	<p>Reinstall and adjust the printhead assembly. Go to <b>“Printhead assembly removal (T650)” on page 4-60</b> or <b>“Printhead assembly removal (T652, T654)” on page 4-61.</b></p>
8	<p>Perform a print test. Does the problem remain?</p>	<p>Contact next highest level of tech support.</p>	<p>Problem solved.</p>



**After image**

The ghost appears on the media which, may be the image from the previous page or part of the page currently printing.

Step	Check	Yes	No
1	Check the media condition. Load new, dry, recommended media. Re-print the defective image. Does the error continue?	Go to step 2.	Problem solved.
2	Check the heat roll and pressure roll. Remove the fuser unit assembly. <div style="text-align: center;">  <b>CAUTION:</b> : Allow the fuser unit assembly to cool down.         </div> Is there contamination or cracks on the heat roll and/or pressure roll?	Replace the fuser unit assembly. Go to <b>“Fuser unit assembly removal (T650, T652, T654)” on page 4-23.</b>	Go to step 4.
3	Perform a print test. Does the problem remain?	Contact next highest level of tech support.	Problem solved.

**Background (fog)**

Step	Check	Yes	No
1	Check the media condition. Load new, dry, recommended media. Re-print the defective image. Does the error continue?	Go to step 2.	Problem solved.
2	Check the media transfer route. Is the media path free of contamination or debris.	Go to step 3.	Remove debris or contamination.
3	Check the print cartridge for proper installation. Is the above component properly installed?	Go to step 4.	Inspect, clean and reinstall replace the print cartridge.
4	Check the transfer roll assembly for contamination and wear. Is the above component free of excess wear and contamination?	Go to step 5.	Replace the transfer roll assembly. Go to <b>“Transfer roll assembly removal (T650, T652, T654)” on page 4-78.</b>
5	Check the HVPS card assembly for proper connection. Is the above component connected properly?	Go to step 6.	Replace the connections.
6	Check the printhead installation. Is the above component properly installed?	Go to step 7.	Reinstall and adjust the printhead assembly. Go to <b>“Printhead assembly removal (T650)” on page 4-60</b> or <b>“Printhead assembly removal (T652, T654)” on page 4-61.</b>

Step	Check	Yes	No
7	Perform a print test. Does the problem remain?	Contact next highest level of tech support.	Problem solved.

### Skew



The printed image is not paralleled with both sides of the media.

Step	Check	Yes	No
1	Check printer installation placement. Check the installation surface for irregularities. Check for damaged printer caster. Is the setup surface normal?	Go to step 2.	Correct the installation placement.
2	Properly load media into the media tray assembly and ensure all guides are set correctly. Properly install the media tray assembly into the printer. Re-print the defective image. Does the error continue?	Go to step 3.	Problem solved.
3	Check for obstructions in the area of the media feed units. Are the media feed unit assembly free from any obstructions?	Go to step 4.	Remove obstructions.
4	Check the transfer roll assembly for contamination and wear. Is the above component free of excess wear and contamination?	Go to step 5.	Replace the transfer roll assembly. Go to <b>“Transfer roll assembly removal (T650, T652, T654)”</b> on page 4-78.

Step	Check	Yes	No
5	Check the aligner assembly for proper adjustment. Go to <b>“Alignment assembly adjustment” on page 4-4.</b> Does the problem remain?	Go to step 6.	Replace the aligner assembly. Go to <b>“Output cover assembly removal (T650, T652, T654)” on page 4-54.</b>
6	Perform a print test. Does the problem remain?	Contact next highest level of tech support.	Problem solved.

**Media damage**



Step	Check	Yes	No
1	Check printer installation placement. Check the installation surface for irregularities. Check for missing printer foot. Is the setup surface normal?	Go to step 2.	Correct the installation placement.
2	Check the media feed. Remove the media tray assembly. Properly load media in the media tray assembly. Properly install the media tray assembly in the printer. Re-print the defective image. Does the error continue?	Go to step 3.	Problem solved.
3	Check the media condition. Load new, dry, recommended media. Re-print the defective image. Does the error continue?	Go to step 4.	Problem solved.

Step	Check	Yes	No
4	<p>Check the transfer roll assembly for contamination and wear.</p> <p>Is the above component free of excess wear and contamination?</p>	Go to step 5.	<p>Replace the transfer roll assembly.</p> <p>Go to <b>“Transfer roll assembly removal (T650, T652, T654)”</b> on page 4-78.</p>
5	<p>Check the aligner assembly for proper adjustment.</p> <p>Go to <b>“Operator panel door assembly removal (models X651, X652, X654, and X656)”</b> on page 4-49.</p> <p>Does the problem remain?</p>	Go to step 6.	<p>Replace the aligner assembly.</p> <p>Go to <b>“Output cover assembly removal (T650, T652, T654)”</b> on page 4-54.</p>
6	<p>Check the heat roll and pressure roll.</p> <p>Remove the fuser unit assembly.</p> <div style="text-align: center;">  <p><b>CAUTION:</b> : Allow the fuser unit assembly to cool down.</p> </div> <p>Is there contamination or cracks on the heat roll and/or pressure roll?</p>	<p>Replace the fuser unit assembly.</p> <p>Go to <b>“Fuser unit assembly removal (T650, T652, T654)”</b> on page 4-23.</p>	<p>Inspect the machine for obstructions in the media path.</p>

**No fuse**

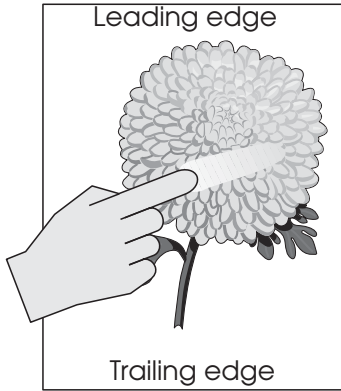

Step	Check	Yes	No
1	Check the fuser unit assembly installation. Is the fuser unit assembly properly installed?	Go to step 2.	Reinstall the fuser unit assembly.
2	Check the media condition. Load new, dry, recommended media. Re-print the defective image. Does the problem remain?	Go to step 3.	Problem solved.
3	Check the heat roll and pressure roll. Remove the fuser unit assembly.  <div style="text-align: center;">  <p><b>CAUTION:</b> : Allow the fuser unit assembly to cool down.</p> </div> Is there contamination or cracks on the heat roll and/or pressure roll?	Replace the fuser unit assembly.  Go to <b>“Fuser unit assembly removal (T650, T652, T654)” on page 4-23.</b>	Go to step 4.
4	Check the LVPS card assembly for proper connection. Is the above component connected properly?	Replace the LVPS card assembly.  Go to <b>“System card assembly removal (T650, T652, T654, T656)” on page 4-76</b> or <b>“LVPS card assembly removal (T652, T654)” on page 4-31.</b>	Remove then reinsert the LVPS card assembly.

Step	Check	Yes	No
5	Perform a print test. Does the problem remain?	Replace the system card assembly.  Go to <b>“System card assembly removal (T650, T652, T654, T656)” on page 4-76.</b>	Problem solved.

### Network service check

**Note:** Before starting this service check, print out the network setup page. This page is found under Menu - Reports - Network Settings. Consult the network administrator to verify that the physical and wireless network settings displayed on the network settings page for the device are properly configured. If a wireless network is used, verify that the printer is in range of the host computer or wireless access point, and there is no electronic interference. Have the network administrator verify that the device is using the correct SSID, and wireless security protocols. For more network troubleshooting information, consult the Lexmark Network Setup Guide.

Step	Questions / actions	Yes	No
1	If the device is physically connected to the network, verify that the ethernet cable is properly connected on both ends. Is the cable properly connected?	Go to step 3. If the network is wireless, got to step 3.	Go to step 2.
2	Connect the ethernet cable. Did this fix the problem?	Problem resolved	Go to step 3.
3	Check the printer's online status under Printers and Faxes on the host computer. Delete all print jobs in the print queue. Is the printer online and in a <b>Ready</b> state.	Go to step 5.	Go to step 4.
4	Change the printer status to online. Did this fix the issue?	Problem resolved.	Go to step 5.
5	Does the IP address displayed on the network settings page match the IP address in the port of the drivers using the printer?	Go to step 10.	Go to step 6.
6	Does the LAN use DHCP? <b>Note:</b> A printer should use a static IP address on a network.	Go to step 7.	Go to step 9.
7	Are the first two segments if the IP address 169.254?	Go to step 8.	Go to step 9
8	POR the printer. Is the problem resolved	Problem resolved	Go to step 10.
9	Reset the address on the printer to match the IP address on the driver. Did this resolve the issue?	Problem fixed.	Go to step 10.

Step	Questions / actions	Yes	No
10	Have the network administrator verify that the printer and PC's IP address have identical subnet addresses. Are the subnet addresses the same?	Go to step 12.	Go to step 11.
11	Using the subnet address supplied by the network administrator, assign a unique IP address to the printer. <b>Note:</b> The printer IP address should match the IP address on the printer driver. Did this fix the problem?	Problem resolved.	Go to step 12.
12	Is the device physically connected (ethernet cable) to the network?	Go to step 13.	Go to step 15.
13	Try using a different ethernet cable. Did this remedy the situation?	Problem resolved	Go to step 14.
14	Have the network administrator check the network drop for activity. Is the drop functioning properly?	Replace the system card. Go to " <b>System card assembly removal (T650, T652, T654, T656)</b> " on page 4-76.	Contact the network administrator.
15	Is the printer on the same wireless network as the other devices?	Go to step 17.	Go to step 16.
16	Assign the correct wireless network to the printer. Did this fix the problem?	Problem resolved	Go to step 17.
17	Are the other devices on the wireless network communicating properly?	Go to step 18.	Contact the network administrator.
18	Verify that the wireless card is properly seated on the controller board. Is the wireless card seated correctly?	Go to step 20.	Go to step 19.
19	Properly reseal the wireless card. Did this fix the problem?	Problem resolved.	Go to step 20.
20	Is the antenna damaged?	Go to step 22.	Go to step 21.
21	Replace the antenna. Did this fix the problem?	Problem resolved	Go to step 22.
22	Verify that the antenna is properly connected to the wireless card. Is it connected correctly?	Go to step 24.	Go to step 23.
23	Properly connect the antenna. Did this fix the problem?	Problem resolved	Go to step 24.
24	Check pin 6 for +3.3V, and Pin 5 for +5V. on connector <> of the controller board. Pins 1 and 4 are GND. Are the voltages and GNDs correct?	Replace the wireless card.	Replace the system card. Go to " <b>System card assembly removal (T650, T652, T654, T656)</b> " on page 4-76



### 3. Diagnostic aids

This chapter explains the tests and procedures to identify printer failures and verify repairs have corrected the problem.

#### Understanding the printer control panel (models T650, T652, and T654)

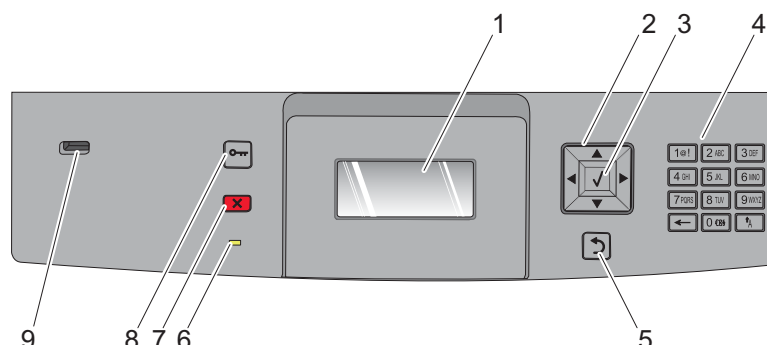











Item		Description
1	Display	Shows messages and pictures that communicate the status of the printer.
2	Navigation buttons	Press the up or down arrow buttons to scroll through menus or menu items, or to increase or decrease a value when entering numbers.
3	Select	Press the left or right arrow buttons to scroll through menu settings (also called values or options), or to scroll through text that rolls to another screen. <ul style="list-style-type: none"> <li>Opens a menu item and displays the available values or settings. The current setting is indicated by an asterisk (*).</li> <li>Saves a displayed menu item as the new user default setting.</li> </ul> <p><b>Note:</b> When a new setting is saved as the user default setting, it remains in effect until a new setting is saved or until factory defaults are restored.</p> <p><b>Note:</b> Settings chosen from a software program can also change or override the user default settings selected from the printer control panel.</p>
4	Keypad	Enter numbers or symbols on the display.
5	Back	Returns the display to the previous screen.
6	Indicator light	Indicates the printer status: <ul style="list-style-type: none"> <li><b>Off</b>—The power is off.</li> <li><b>Blinking green</b>—The printer is warming up, processing data, or printing.</li> <li><b>Solid green</b>—The printer is on, but idle.</li> <li><b>Solid red</b>—Operator intervention is needed.</li> </ul>
7	Stop	Stops all printer activity. <p>A list of options is offered once Stopped appears on the display.</p>

Item		Description
8	Menu 	Opens the menu index <b>Note:</b> The menus are available only when the printer is in the <b>Ready</b> state.
9	USB	Insert a flash drive into the front of the printer to print saved files. <b>Note:</b> Only the front USB port supports flash drives.

## Accessing service menus (models T650, T652, and T654)

There are different test menus that can be accessed during POR to identify problems with the printer.

Diagnostics Mode	<ol style="list-style-type: none"> <li>1. Turn off the printer.</li> <li>2. Press and hold  and .</li> </ol>  <ol style="list-style-type: none"> <li>3. Turn on the printer.</li> <li>4. Release the buttons after 10 seconds.</li> </ol>	<p>The Diagnostics Mode group contains the settings and operations used while manufacturing and servicing the printer.</p> <p>See <b>“Diagnostics mode (models T650, T652, and T654)”</b> on page 3-3 for more information.</p>
Configuration Menu	<ol style="list-style-type: none"> <li>1. Turn off the printer.</li> <li>2. Press and hold  and .</li> </ol>  <ol style="list-style-type: none"> <li>3. Turn on the printer.</li> <li>4. Release the buttons after 10 seconds.</li> </ol>	<p>The Configuration Menu group contains a set of menus, settings, and operations which are infrequently required by a user. Generally, the options made available in this menu group are used to configure a printer for operation.</p> <p>See <b>“Configuration menu (CONFIG MENU) (models T650, T652, and T654)”</b> on page 3-25 for more information.</p>
Flash system code mode	<ol style="list-style-type: none"> <li>1. Turn off the printer.</li> <li>2. Press and hold , , and .</li> </ol>  <ol style="list-style-type: none"> <li>3. Turn on the printer.</li> <li>4. Release the buttons after 10 seconds.</li> </ol>	

To run the printer diagnostic tests described in this chapter, you must put the printer in Diagnostic Mode.

## Diagnosics mode (models T650, T652, and T654)

### Entering Diagnostics mode (models T650, T652, and T654)

1. Turn the printer off.
1. Press and hold ▼ and ►.
2. Turn the printer on.
3. Release the buttons after 10 seconds.

### Available tests

The tests display on the operator panel in the order shown:

<b>REGISTRATION</b>	See <b>“REGISTRATION”</b> on page 3-5
Top Margin	
Bottom Margin	
Left Margin	
Right Margin	
Quick Test	See <b>“Quick Test”</b> on page 3-6
<b>PRINT TESTS</b>	
Tray 1	See <b>“Input source tests”</b> on page 3-7
Tray 2 (if installed)	
Tray 3 (if installed)	
Tray 4 (if installed)	
Tray 5 (if installed)	
MP Feeder	
Env Feeder (if installed)	
Prt Quality Pgs	See <b>“Print quality pages (Prt Quality Pgs)”</b> on page 3-7
<b>HARDWARE TESTS</b>	
Panel Test	See <b>“Panel Test”</b> on page 3-8
Button Test	See <b>“Button Test”</b> on page 3-8
DRAM Test	See <b>“DRAM Test”</b> on page 3-8
USB HS Test Mode	See <b>“USB HS Test Mode”</b> on page 3-9
RFID Option Test	See <b>“RFID Option Test”</b> on page 3-10

<b>DUPLEX TESTS</b> (if installed)	
Quick Test	See <b>“Quick Test (duplex)”</b> on page 3-12
Top Margin	See <b>“Top Margin (duplex)”</b> on page 3-13
Sensor Test	See <b>“Sensor Test (duplex)”</b> on page 3-13
Motor Test	See <b>“Motor Test (duplex)”</b> on page 3-14
Duplex Feed 1	See <b>“Duplex Feed 1”</b> on page 3-14
Duplex Feed 2	See <b>“Duplex Feed 2”</b> on page 3-14
<b>INPUT TRAY TESTS</b>	
Feed Tests	See <b>“Feed Tests (input tray)”</b> on page 3-15
Sensor Test	See <b>“Sensor Test (input tray)”</b> on page 3-15
<b>OUTPUT BIN TESTS</b>	
Feed Tests	See <b>“Feed Tests (output bins)”</b> on page 3-15
Feed To All Bins	See <b>“Feed To All Bins”</b> on page 3-16
Sensor Test	See <b>“Sensor Test (standard output bin)”</b> on page 3-16
Deflector Test (if 5-bin installed)	See <b>“Deflector Test”</b> on page 3-18
<b>FINISHER TESTS</b> (if installed)	
Staple Test	See <b>“Staple Test”</b> on page 3-18
Feed Tests	See <b>“Feed Tests (finisher)”</b> on page 3-18
Sensor Test	See <b>“Sensor Test (finisher)”</b> on page 3-18
<b>BASE SENSOR TEST</b>	
Toner	See <b>“Toner Level—Toner level sensor (remove the cartridge and replace to actuate the sensor)”</b> on page 3-19
Input	See <b>“Input—Input sensor”</b> on page 3-19
Output	See <b>“Output—Output (exit) sensor”</b> on page 3-19
NarrowMedia	See <b>“NarrowMedia—Output (exit) sensor”</b> on page 3-19
Front Door	See <b>“Front Door—Front door sensor”</b> on page 3-19
<b>PRINTER SETUP</b>	
Defaults	See <b>“Defaults”</b> on page 3-19
Page Count	See <b>“Printed Page Count”</b> on page 3-19
Perm Page Count	See <b>“Perm Page Count (permanent page count)”</b> on page 3-20
Serial Number	See <b>“Serial Number”</b> on page 3-20
Engine Setting 1 through 4	See <b>“Engine Setting 1 through 16”</b> on page 3-20
Model Name	See <b>“Model Name”</b> on page 3-20
Configuration ID	See <b>“Configuration ID”</b> on page 3-20
Edge to Edge	See <b>“Edge to Edge”</b> on page 3-21

<b>EP SETUP</b>	
EP Defaults	See <b>“EP Defaults” on page 3-21</b>
Fuser Temp	See <b>“Fuser Temperature (Fuser Temp)” on page 3-21</b>
Fuser Page Count	See <b>“Fuser Page Count” on page 3-21</b>
Warm Up Time	See <b>“Warm Up Time” on page 3-21</b>
Transfer	See <b>“Transfer” on page 3-21</b>
Print Contrast	See <b>“Print Contrast” on page 3-22</b>
Charge Roll	See <b>“Charge Roll” on page 3-22</b>
Gap Adjust	See <b>“Gap Adjust” on page 3-22</b>
<b>EVENT LOG</b>	
Display Log	See <b>“Display Log” on page 3-23</b>
Print Log	See <b>“Print Log” on page 3-23</b>
Clear Log	See <b>“Clear Log” on page 3-24</b>
<b>EXIT DIAGNOSTICS</b>	

### ***Exiting Diagnostics mode (models T650, T652, and T654)***

Select **Exit Diagnostics** to exit the Diagnostics menu. **Resetting the Printer** displays, the printer performs a POR, and returns to Ready mode.

### **REGISTRATION**

Print registration makes sure the printing is printed properly aligned on the page.

The settings available are:

- Top Margin
- Bottom Margin
- Left Margin
- Right Margin
- Quick Test

To set print registration:

1. Select **REGISTRATION** from the DIAGNOSTICS menu.

2. Select Quick Test, and press .

To print the Quick Test page:

**a.** Press  until the  appears next to **Quick Test**.

**b.** Press .

The message **Quick Test Printing...** appears on the display.

Retain this page to determine the changes you need to make to the margins settings.

3. Use  or  to select the margin setting you need to change, and press .

4. Use  to decrease or  to increase the values, and press  to reset the value.

The message **submitting selection** displays, and the original REGISTRATION screen appears with the  beside the previously selected margin setting.

The print registration range is:

Variable	Description	Value	Direction of change
T=	Top margin	-25 to +25 Each increment causes approximately 4 pels shift (at 600 dpi).	A positive change moves the image down the page and increases the top margin. A negative change moves the image up and decreases the top margin.
B=	Bottom margin	-20 to +20 Each increment causes approximately 0.55 mm shift in the bottom margin.	A positive change compresses the image so it appears to move down the page and a negative change moves the image up.
L=	Left margin	-25 to +25	A positive change moves the image to the right, and a negative change moves the image to the left. No compression occurs.
R=	Right margin	- 99 to +99	A positive change moves the image to the right, and a negative change moves the image to the left.

5. Continue changing the settings by repeating steps 2 through 4.
6. Print another copy of the Quick Test to verify your changes.
7. To exit REGISTRATION, press **Back** .

### Quick Test

The Quick Test contains the following information:

- Device information
- Current page count, installed memory
- Processor speed
- Serial number
- Engine ID
- System card ID
- Printer revision levels
- Printer margin settings
- Alignment diamonds at the top and bottom
- Horizontal lines to check for skew

To print the Quick Test page:

**Note:** Print the Quick Test Page on letter or A4 paper.

1. Select **REGISTRATION** from **DIAGNOSTICS**.
2. Press ▼ until the ✓ appears next to **Quick Test**.

The message **Quick Test Printing...** appears on the display.

Once the Quick Test Page completes printing, the Registration screen displays again.

## PRINT TESTS

### Input source tests

The purpose of the diagnostic Print Tests is to verify that the printer can print on media from each of the installed input options. The contents of the Print Test Page varies depending on the media installed in the selected input source.

Check each Test Page from each source to assist in print quality and paper feed problems.

To run the Print Test Page:

1. Select **PRINT TESTS** from the Diagnostics menu.
2. Select the media source.
  - Tray 1
  - Tray 2 (if installed)
  - Tray 3 (if installed)
  - Tray 4 (if installed)
  - Tray 5 (if installed)
  - Multi-Purpose Feeder (if installed)
  - Envelope Feeder (if installed)
3. Select **Single** or **Continuous**.
  - If **Single** is selected, a single page is printed.
  - If **Continuous** is selected, printing continues until **Stop**  is pressed to cancel the test.

If a source is selected that contains envelopes, an envelope test pattern is printed. If Continuous is selected, the test pattern is printed only on the first envelope.

**Note:** The Print Test Page always prints on one side of the paper, regardless of the duplex setting or the presence of a duplex option.

Press **Back**  to return to PRINT TESTS.

### Print quality pages (Prt Quality Pgs)

The purpose of this diagnostic function is to allow printing of the print quality test pages with the toner cartridge lockout function disabled. The print quality pages consist of four pages. Page one contains a mixture of graphics and text. Page two is gray with two one inch black squares located on the bottom right. Page three is solid black page and page four is blank. If duplex is turned on, the pages are duplexed. The Print Quality Test pages are printed in English and must always be printed on letter, legal, or A4 paper.

To run the Print Quality Test Pages, select **Prt Quality Pgs** from PRINT TESTS. The message **Printing Quality Test Pages** is displayed.

The following is included in the DIAGNOSTICS version of the first print quality test page:

- Device information
- Printer revision levels
- Cartridge information
- Printer margin settings
- EP setup
- Printer setup
- Minimum stroke width

**Note:** The print quality test pages can also be printed from the Configuration menu (CONFIG MENU), however a cartridge must be installed with a machine class ID matching the machine class ID stored in

NVRAM. The CONFIG MENU print quality test pages are identical to the DIAGNOSTIC print quality test pages with the exception of the first page. The first print quality test page from the CONFIG MENU does not include EP or Printer setup.

## HARDWARE TESTS



Select the following Hardware Tests from this menu:

- Panel Test
- Button Test
- DRAM Test
- USB HS Test Mode

### Panel Test

This test automatically toggles each pixel of the operator panel through every contrast level beginning with the darkest to the brightest. This test continues until you press **Stop** .

### Button Test

The Button Test verifies the operation of the buttons on the operator panel. When you select Button Test, a diagram of the operator panel appears on the panel. When you press a button on the operator panel, an **x** appears on the corresponding diagram. When you release the button, an **x** disappears. Pressing **Back**  or **Stop**  cancels the test.

### DRAM Test

The purpose of this test is to check the validity of DRAM memory, both standard and optional. The test writes patterns of data to DRAM to verify that each bit in memory can be set and read correctly.

To run the DRAM Test:

1. Select **DRAM Test** from the menu.

The message **DRAM Test Testing...** displays. Then the message **Resetting Printer** appears, and the power indicator light *blinks* green.

The following type of message appears:

<b>DRAM Test</b>	<b>xxx MB</b>
<b>P:#####</b>	<b>F:####</b>

- xxx represents the installed DRAM size.
- P:##### represents the number of times the memory test has passed and finished successfully. Initially 000000 displays with the maximum pass count being 999,999.
- F:#### represents the number of times the memory test has failed and finished with errors. Initially 0000 displays with the maximum fail count being 99,999. Initially only four digits appear, but additional digits appear as needed.

Each time a test is completed, the number of pass and failures is incremented. If the test fails, the message **Failure** displays for approximately three seconds, and the failure count increases by one.

The test continues until all standard and optional DRAM is tested. Once the maximum pass count or fail count is reached, the test is stopped, the power indicator is turned on solid, and the final results display.

To stop the test before completion, turn the printer off.



## USB HS Test Mode

1. Select **USB HS Test Mode** from HARDWARE TESTS.
2. Press ▼ until the ✓ appears next to the Port to be tested, and then press .
3. Select the desired Test, and then press .

Port	Test	Appears on the display
Port 0	Test J Test K Test SEO NAK Test Packet Test Force Enabled	USB High Speed Certification Testing...
Port 1	Test J Test K Test SEO NAK Test Packet Test Force Enabled	USB High Speed Certification Testing...
Port 2	Test J Test K Test SEO NAK Test Packet Test Force Enabled	USB High Speed Certification Testing...
Port 3	Test J Test K Test SEO NAK Test Packet Test Force Enabled	USB High Speed Certification Testing...

To stop testing before completion, turn the printer off.

## RFID Option Test



This test confirms that the RFID firmware and hardware are working properly. In the event that the test fails, it is recommended that the test be repeated to confirm that the problem is not intermittent or caused by a single failed piece of RFID media.

**Note:** If the printer has problems picking RFID media from a tray, try using a shorter stack of media (< 100 sheets) before assuming a pick mechanism problem.

To run the RFID Option Test, select **RFID Option Test** from the menu.





1. Load RFID media in Tray 2, and then press **Continue**. The test page will be printed.

**Note:** For this test to work properly, the RFID media used for the test should contain an RFID tag that is positioned within the first-half of the page from the leading edge.



If the page looks like this:	If the page looks like this:
<p style="text-align: center;">T65x RFID Option Test Step 1.</p> <p style="text-align: center;">Step 1 is complete.</p> <p>1. Place this sheet in Tray 2 face-down with the arrow pointing toward the front of the printer. 2. Press Continue.</p> <div style="text-align: center;">  </div>	<p style="text-align: center;">T65x RFID Option Test Step 1.</p> <p style="text-align: center;">Step 1 is complete.</p> <p>1. Place this sheet in Tray 2 face-down with the arrow pointing toward the front of the printer. 2. Press Continue.</p> <div style="text-align: center;">     </div>
<p>Then step 1 of the test passed. Proceed to step 2</p>	<p>Then the test has failed. This is an indication that the RFID tag could not be written to.</p> <p>Possible causes:</p> <ol style="list-style-type: none"> <li>1. Bad RFID media</li> <li>2. RFID UHF option failure</li> </ol> <p>Try the test again with a new piece of RFID media. If the test fails again, replace the RFID UHF option.</p>

- 2. Reload RFID media in Tray 2 with the RFID media that was just printed in step 1, and then press **continue**. The test page will be printed.

**Note:** The sheet should be placed face down with the arrow pointing toward the front of the printer.

If the page looks like this:	If the page looks like this:	If the page looks like this:
<p style="text-align: center;"><b>T65x RFID Option Test Step 1.</b></p> <p style="text-align: center;">Step 1 is complete.</p> <p>1. Place this sheet in Tray 2 face-down with the arrow pointing toward the front of the printer. 2. Press Continue.</p> <div style="text-align: center;">  </div> <p style="text-align: center;"><b>T65x RFID Option Test Step 2.</b></p> <p style="text-align: center;">Step two is complete.</p> <p>1. Place a sheet of plain paper in Tray 2. 2. Press Continue.</p>	<p style="text-align: center;"><b>T65x RFID Option Test Step 1.</b></p> <p style="text-align: center;">Step 1 is complete.</p> <p>1. Place this sheet in Tray 2 face-down with the arrow pointing toward the front of the printer. 2. Press Continue.</p> <div style="text-align: center;">  </div> <p style="text-align: center;"><b>T65x RFID Option Test Step 2.</b></p> <p style="text-align: center;">Step two is complete.</p> <p>1. Place a sheet of plain paper in Tray 2.</p> <div style="text-align: center;">  </div>	<p style="text-align: center;"><b>T65x RFID Option Test Step 2.</b></p> <p style="text-align: center;">Step two is complete.</p> <p>1. Place a sheet of plain paper in Tray 2.</p> <div style="text-align: center;">  </div>
<p>Then step 2 of the test passed. Proceed to step 3</p>	<p>Then the test has failed. This is an indication that the RFID tag could not be read. Possible causes: 1. Bad RFID media 2. RFID UHF option failure Try the test again with a new piece of RFID media. If the test fails again, replace the RFID UHF option.</p>	<p>Then the test has failed. This is an indication that the RFID tag could not be read because the RFID sheet printed in step 1 was not reloaded (or reloaded incorrectly) for step 2. Try the test again with a new piece of RFID media and make sure the sheet printed in step 1 is reloaded into Tray 2 during step 2.</p>

3. Load plain media in Tray 2, and then press **Continue**. The test page will be printed.

If the page looks like this:	If the page looks like this:
<p>T65x RFID Option Test Step 3.</p> <p>Step three is complete.</p> <p>If this image</p>  <p>appears at the bottom of this sheet, the test is a SUCCESS.</p> 	<p>T65x RFID Option Test Step 3.</p> <p>Step three is complete.</p> <p>If this image</p>  <p>appears at the bottom of this sheet, the test is a SUCCESS</p>
<p>Then step 3 of the test passed and the RFID Option Test is complete. The RFID firmware and hardware are working properly.</p>	<p>Then the test has failed.</p> <p>This is an indication that the printer was able to read an RFID tag when it was not supposed to.</p> <p>Possible causes:</p> <ol style="list-style-type: none"> <li>1. RFID media was printed instead of plain media.</li> <li>2. A separate RFID tag may be placed in close proximity to the RFID option.</li> <li>3. RFID UHF option failure</li> </ol> <p>Try the test again, making sure that plain media is used for step 3. If the test fails again, inspect the printer to make sure there are no RFID tags in close proximity to the RFID option. For example, if an RFID tag was applied to the printer front cover itself, this tag may be causing problems with the RFID reader. If no problems found, replace the RFID UHF option.</p>

## DUPLEX TESTS

### Quick Test (duplex)

This test prints a duplex version of the Quick Test that can be used to verify that the correct placement of the top margin on the back side of a duplex page. You can run one duplexed page (**Single**), or continue printing

duplexed pages (**Continuous**) until **Stop**  is pressed. For information about changing the margin, see **“Top Margin (duplex)” on page 3-13**.

**Note:** Before you set the duplex top margin, be sure to set the registration. See **“REGISTRATION” on page 3-5**.

The paper you choose to print the page on should be either Letter or A4.

To run the Quick Test (duplex):



1. Select **Quick Test** from DUPLEX TESTS.
2. Select **Single** or **Continuous**.
  - The single Duplex Quick test cannot be canceled.
  - The printer attempts to print the Quick Test Page from the default paper source. If the default paper source only supports envelopes, then the page is printed from Tray 1.
  - Check the Quick Test Page for the correct offset between the placement of the first scan line on the front and back side of a duplexed sheet.

The single test stops automatically when a single duplex sheet is printed, and the continuous test continues until you press **Stop** .

### Top Margin (duplex)

This setting controls the offset between the first scan line on the front of the duplex page and the first scan line on the back of the page. Therefore, be sure to set the top margin in REGISTRATION before setting the duplex top margin. See **“REGISTRATION” on page 3-5**.



To set the Top Margin (duplex):

1. Print the Quick Test (duplex):
  - a. Select **Quick Test** from DUPLEX TESTS.
  - b. Select **Single**.
  - c. Hold the page to the light to see the whether the top margin of the backside aligns with the top margin of the frontside.
2. Select **Top Margin** from DUPLEX TESTS.
3. Use  or  to select the margin setting you need to change.
  - Each increment shifts the duplex top margin by 1/100 of an inch.
  - The Top Margin (duplex) range is -25 to +25, and the default value is 2.
  - An increase moves the top margin down and widens the top margin. A decrease moves the top margin upward and narrows the top margin.
4. Press .
5. Print the Quick Test (duplex) again to verify the adjustment. Repeat if necessary.

### Sensor Test (duplex)

This test is used to determine whether or not the duplex sensors and switches are working correctly. The test allows you to actuate the duplex input sensor located in the back part of the duplex unit and the duplex exit sensor located in the return paper path.

1. Select **Sensor Test** from DUPLEX TESTS.  
The message **Sensor Test Testing** displays.
2. Manually actuate each of the duplex sensors. When the sensor/switch is closed, **CL** (closed) displays, and when the sensor/switch is open, **OP** (open) displays.

- Duplex input sensor
  - Duplex exit sensor
3. Press **Back**  or **Stop**  to exit the test.

### Motor Test (duplex)

This test lets you test the duplex option paper feed drive system, and verify that the power and velocity values are acceptable. The duplex runs the DC motor at high speed and low speed, taking an average of the power (PWM) required for each speed and calculating the KE value.

To run the Motor Test (duplex):

1. Select **Motor Test** from DUPLEX TESTS.  
The power indicator light *blinks*, and the message **Motor Test Testing** displays.
2. When the motor stops, and has passed the test, the following results are displayed.

<p><b>Motor Test</b> <b>Test Passed</b></p>
---

3. Press **Back**  or **Stop**  to exit the test.

### Duplex Feed 1

This test feeds a blank sheet of paper to the duplex paper stop position 1. This test can be run using any of the supported paper sizes.



To run the Duplex Feed 1 Test:

1. Select **Duplex Feed 1** from DUPLEX TESTS.  
The power indicator blinks while the paper is feeding, and the message **Duplex Feed 1 Feeding...** displays.  
The message **Duplex Feed 1 Clear Paper** displays when the paper reaches paper stop position 1, and the power indicator turns on solid.
2. Remove the media from the duplex unit, and clear the message on the operator panel by pressing **Stop** .

### Duplex Feed 2

This test feeds a blank sheet of paper to the duplex paper stop position 2. This test can be run using any of the supported paper sizes.

To run the Duplex Feed 2 Test:

1. Select **Duplex Feed 2** from DUPLEX TESTS.  
The power indicator blinks while the paper is feeding, and the message **Duplex Feed 2 Feeding...** displays.  
The message **Duplex Feed 2 Clear Paper** displays when the paper reaches the duplex paper stop position 2, and the power indicator turns on solid.
2. Remove the media from the duplex unit, and clear the message on the operator panel by pressing **Back**  or **Stop** .

## INPUT TRAY TESTS

## Feed Tests (input tray)

This test lets the servicer observe the paper path as media is feeding through the printer. A blank sheet of paper feeds through the printer as the laser turns off during this test. The only way to observe the paper path is to open the lower front door that is used to access the envelope or multipurpose feeder. The paper is placed in the output bin.

To run the Input Tray Feed Tests:

1. Select **Feed Tests** from INPUT TRAY TESTS.
2. Select the input source from the sources displayed on the Feed Tests menu. All installed sources are listed.
3. Select either **Single** or **Continuous**.
  - **Single**—feeds one sheet of media from the selected source.
  - **Continuous**—media continues feeding from the selected source until **Stop**  is pressed.

## Sensor Test (input tray)



This test is used to determine if the input tray sensors are working correctly. To run the Input Tray Sensor Test:

1. Select the **Sensor Test** from INPUT TRAY TESTS.
2. Select the input source from the sources displayed on the Sensor Test menu. All installed sources are listed.
3. Select the sensor to test. Various sources have different combinations of sensors. See the table below:

### Tray sensor support by source

Source	Empty (Input tray empty sensor)	Low (Input tray paper low sensor)	passThru (Input tray pass thru sensor)
Tray 1	X	X	
Tray 2	X	X	X
Tray 4	X	X	X
Tray 5	X	X	X
Multi-Purpose Feeder	X		
Envelope feeder	X		X

[*sensor selected*]=OP displays.

- Empty—Input tray empty sensor
  - Low—Input tray paper low sensor
  - passThru—Input tray pass thru sensor
4. Once this message displays, the servicer can manually actuate each sensor. The tray empty sensor can be actuated by hand, however a sheet of paper can be used to cover the pass thru sensor. When the sensor is closed, **closed** displays; when the sensor is open, **open** displays.
  5. Press **Back**  or **Stop**  to exit the test.

## OUTPUT BIN TESTS

### Feed Tests (output bins)

Use these tests to verify that media can be fed to a specific output bin. Media is fed from the default input source to the selected output bin. No information is printed on the media fed to the output bin because the printhead is not engaged during this test. These tests can use any media size or envelope supported by the printer.

**Note:** If the Configure Bins printer setting is Link rather than Mailbox, the printer selects its own internal bin linking regardless of which output bin is selected for the feed test.

To run the Feed Tests for the output bins:

1. Select **Feed Tests** from the OUTPUT BIN TESTS.
2. Select the output bin you want the paper to exit into. The standard bin as well as any output option bin installed on the printer is shown on the menu. (The output bins are displayed in the order installed on the printer.)
3. Select either **Single** or **Continuous**.
  - **Single**—feeds one sheet of media from the selected source.
  - **Continuous**—media continues feeding from the selected source until **Stop**  is pressed.

Press **Back**  to return to OUTPUT BIN TESTS.

### Feed To All Bins

This test can be used to verify that the printer can feed media to the standard bin or any installed output options. No information will be printed on the test pages, as the printhead is not engaged during the feed test. The media feeds from the default paper source.

To run the Feed To All Bins Test:

Select **Feed To All Bins** from OUTPUT BIN TESTS.

The printer feeds a separate piece of media to the standard bin first, then it feeds a separate piece of media to each output bin installed in the following order:

Order sheets are fed	Output bins	Order sheets are fed	Output bins	Order sheets are fed	Output bins
1	Standard bin	9	Bin #8	17	Bin #5
2	Bin #1	10	Bin #9,	18	Bin #4
3	Bin #2	11	Bin #10	19	Bin #3
4	Bin #3	12	Bin #10	20	Bin #2
5	Bin #4	13	Bin #9	21	Bin #1
6	Bin #5	14	Bin #8	22	Standard bin
7	Bin #6	15	Bin #7		
8	Bin #7	16	Bin #6		

The test is continuous until **Stop**  is pressed.

Press **Back**  to return to OUTPUT BIN TESTS.

### Sensor Test (standard output bin)

This test is used to verify if the standard bin sensor is working correctly.





To run the Sensor Test for the standard bin:

1. Select **Sensor Test** from OUTPUT BIN TESTS.
2. Select **Standard Bin** from Sensor Tests.
3. **Standard Bin Testing** displays briefly, and then **Bin Empty empty** displays.
4. Select **NearFull** or **Full** sensor to test.

The following screen is displayed:

```
Standard Bin x
Full=Open NearFull=Open
Bin Empty empty
```

- Full—Bin full sensor
  - NearFull—Bin near full sensor
5. Manually actuate the bin sensor by moving the flag in and out of the sensor. The display indicates **Open** when the flag is out of the sensor and **Closed** when the flag is in the sensor.
  6. Press **Back**  or **Stop**  to exit the test.



### Sensor Test (Output Expander)

This test is used to determine whether or not the output bin sensor is working correctly for the output expander, if installed.

1. Select **Sensor Test** from OUTPUT BIN TESTS.
2. Select **Output Bin x** ( $x$ =number of the output option to be tested) from Sensor Tests.

The following screen is displayed:

```
Output Bin x
passThru=Open Full=Open NearFull=Open
```



- passThru—Pass thru sensor
  - Full—Bin full sensor
  - NearFull—Bin near full sensor
3. Manually actuate each of the output expander sensors, and the display by each sensor toggles from **Open** to **Closed**.
  4. Press **Back**  or **Stop**  to exit the test.

### Sensor Test (high capacity output stacker)

1. Select **Sensor Test** from OUTPUT BIN TESTS.
2. Select **Output Bin x** ( $x$ =number of the output option to be tested).

The following screen is displayed:

```
HC Bin x TP=OPpassThru=Open Full=Open NearFull=Open
```



- TP—High-capacity top position sensor
  - passThru—High-capacity pass thru sensor
  - Full—High-capacity bin full sensor (lower part of dual sensor)
  - NearFull—High-capacity bin near full sensor (upper part of dual sensor)
3. Manually actuate each of the sensors of the high-capacity stacker, and the display by each sensor toggles from **Open** to **Closed**.
  4. Press **Back**  or **Stop**  to exit the test.

## Sensor Tests (5-bin mailbox)

1. Select **Sensor Tests** from OUTPUT BIN TESTS.
2. Select **Output Bin x** ( $x$ =number of the output option to be tested).

The following screen is displayed:

Output Bin x  
P1=OP P2=OP L=NL

- **passThru**—5-bin mailbox pass thru sensor shows **Open** or **Closed**
  - **mailboxEmpty**—5-bin mailbox empty sensor shows **Normal** for a normal level, **NearFull** for nearly full, and **Full** for full.
3. Manually actuate each of the sensors of the 5-bin mailbox,. The pass thru sensor will indicate Open or Closed and the empty sensor (mailboxEmpty) indicates Normal, NearFull, or Full.
  4. Press **Back**  or **Stop**  to exit the test.

## Deflector Test

This test verifies the functioning of each of the 5-bin mailbox output media deflectors. If more than one 5-bin mailbox is installed, all installed deflectors are tested.

To run the deflector Test, select **deflector Test** from the OUTPUT BIN TESTS. The test runs once and stops.

## StapleSmart FINISHER TESTS

### Staple Test

This test verifies the staple mechanism by sending eight sheets of media from the printers default paper source and stapling the sheets.

To run the Staple Test:

1. Select **Staple Test** from FINISHER TESTS.
2. Select the output bin, and press .

While the test runs the power indicator *blinks* and the message **Staple Test Running...** displays. During the test, no buttons are active and the test cannot be canceled until the test is complete.

### Feed Tests (finisher)

This test is used to verify whether or not media can be fed to a finisher output bin. Eight sheets of blank paper are fed from the default paper source and fed to the finisher output bins.

**Note:** This test can be run using any of the paper sizes supported by the printer.



To run the Feed Test, select **Feed Tests** from FINISHER TESTS. While the feed test runs, the power indicator *blinks*, and the message **Feed Test Running...** displays.

During the test, no buttons are active, and the test cannot be stopped until the test is completed.

### Sensor Test (finisher)

This test can be used to verify whether or not the finisher sensors are working correctly.

To run the Finisher Sensor Test:

1. Select **Sensor Test** from FINISHER TESTS.
2. Select one of the four tests to perform:. Each of the tests displays the individual sensors that can be manually actuated, and the display shows **Open** or **Closed**.
  - **Staple Sensors**
    - Cartridge Present sensor
    - Staple Low sensor
    - Self-priming sensor
    - Home signal sensor
  - **Cover and Door**
    - Finisher top cover sensor
    - Side door sensor
  - **Pass and Media**
    - Finisher pass thru
    - Media sensor
  - **Bin Level**
    - Finisher bin empty
    - Bin full sensor
    - Bin near full
3. Press **Back**  or **Stop**  to exit the test.



## **BASE SENSOR TEST**

This test is used to determine if the sensors located inside the printer are working correctly.

To run the Base Sensor Test:

1. Select **BASE SENSOR TEST** from the DIAGNOSTICS menu.

The following sensors are listed:

- Toner Level—Toner level sensor (remove the cartridge and replace to actuate the sensor)
  - Input—Input sensor
  - Output—Output (exit) sensor
  - NarrowMedia—Output (exit) sensor
  - Front Door—Front door sensor
2. Manually actuate the sensors to verify that each sensor switches from **Open** to **Closed**.
  3. Press **Back**  or **Stop**  to exit the test.

## **PRINTER SETUP**

### **Defaults**

US/Non-US defaults changes whether the printer uses the US factory defaults or the non-US factory defaults. The settings affected include paper size, envelope size, PCL symbol set, code pages, and units of measure.

**WARNING:** Changing this setting resets the printer to factory defaults, and data may be lost. It cannot be undone.

### **Printed Page Count**

The page count can only be viewed and cannot be changed.

To view the page count:

1. Select **Page Count** from PRINTER SETUP.
2. Press **Back**  to return to PRINTER SETUP.

### Perm Page Count (permanent page count)

The permanent page count can only be viewed and cannot be changed.

To view the permanent page count:

1. Select **Perm Page Count** from PRINTER SETUP.
2. Press **Back**  to return to PRINTER SETUP.

### Serial Number

The serial number can only be viewed and cannot be changed.

To view the serial number:

1. Select **Serial number** from PRINTER SETUP.
2. Press **Back**  to return to PRINTER SETUP.

### Engine Setting 1 through 16

**WARNING:** Do not change these settings unless requested to do so by your next level of support.

### Model Name

The model name can only be viewed and cannot be changed.



### Configuration ID

The two configuration IDs are used to communicate information about certain areas of the printer that cannot be determined using hardware sensors. The configuration IDs are originally set at the factory when the printer is manufactured, however the servicer may need to reset Configuration ID 1 or Configuration ID 2 whenever you replace the system board. The IDs consist of eight hexadecimal characters, including 0 through 9 and A through F.

**Note:** When the printer detects a Configuration ID that is not defined or invalid, the following occurs:

- The default standard model Configuration ID is used instead.
- Configuration ID is the only function available in DIAGNOSTICS.
- Unless the menu is in DIAGNOSTICS, **check config ID** displays.

To set the configuration ID:

1. Select **Printer Setup** from the Diagnostic mode.
2. Select **Configuration ID** from the Printer Setup menu.  
**Submitting Selection** displays, followed by the value for Configuration ID 1.
3. Enter the Configuration ID 1.
  - To select a digit or character to change, press  or  until the digit or character is underlined.

- To change a digit or character, press ▲ to increase or ▼ to decrease the value.
- When the last digit is changed, press  to validate the Configuration ID 1.

If **Invalid ID** appears, the entry is discarded, and the previous Configuration ID 1 is displayed on the screen.

If the process is successful, **Submitting Selection** appears on the display, followed by the current value for Configuration ID 2.

4. Repeat the steps for entering the Configuration ID, and press .

If the Configuration ID 2 is validated, **Submitting Selection** appears, and a check ✓ appears next to **Printer Setup**.

5. Restart the printer.

## Edge to Edge

When this setting is On, the text and graphics are shifted to the physical edges of the paper for all margins. When the setting is Off, the normal margins are restored.

## EP SETUP

### EP Defaults

This setting is used to restore each printer setting listed in EP SETUP to its factory default value. Sometimes this is used to help correct print quality problems.

To restore EP Defaults:

1. Select **EP Defaults** from EP SETUP.
2. Select **Restore** to reset the values to the factory settings, and select **Do Not Restore** to exit without changing the settings.

### Fuser Temperature (Fuser Temp)

This adjustment can be used to help solve some customer problems with paper curl on low grade papers and problems with letterheads on some types of media.

The fuser temperature can be adjusted to: Normal, Lower, Lowest. The default is Normal.

### Fuser Page Count

The fuser page count can only be viewed and cannot be changed.

To view the Fuser Page Count:

1. Select **Fuser Page Count** from EP SETUP.
2. Press **Back**  to return to PRINTER SETUP.

### Warm Up Time

You can change the amount of time the printer warms up before allowing pages to print by changing this setting from 0 to 5. The factory sets the warm up at 0 or no warm up time. This time period lets the backup roll heat up and helps reduce curl in some environments.

### Transfer

The transfer can be adjusted to Low, Medium, or High. The default setting is Medium.

### **Print Contrast**

The print contrast setting controls the developer voltage offset.

The print contrast can be adjusted to Low, Medium, or High. The default setting is Medium.

### **Charge Roll**

The charge roll can be adjusted to Low, Medium, or High. The default setting is Medium.

### **Gap Adjust**

The setting adjusts the minimum gap between sheets. Increasing this value may reduce curl of some printed media and eliminate some output bin stacking problems. However, increasing this value also results in slower overall performance, measured in pages per minute. The range of values is 0 to 255, and the default value is 0.

### **Auto Dark Adj**

The Auto Dark Adj can be adjusted to Enable or Disable. The default setting is Enable.

## REPORTS

Prints a Menu Settings Page.

To print the Menu Settings Page:



1. Select **Menu Settings Page** from REPORTS.
2. Press **Back**  to return to DIAGNOSTICS.

## EVENT LOG

### Display Log

The event log provides a history of printer errors. It contains the 12 most recent errors that have occurred on the printer. The most recent error displays in position 1, and the oldest error displays in position 12 (if 12 errors have occurred). If an error occurs after the log is full, the oldest error is discarded. Identical errors in consecutive positions in the log are entered, so there may be repetitions. All 2xx and 9xx error messages are stored in the event log.

To view the event log:

1. Select **Display Log** from EVENT LOG.  
Up to three error codes display at a time. Press  or  to view additional error codes.
2. Press **Back**  to return to the EVENT LOG menu.

### Print Log

Additional diagnostic information is available when you print the event log from DIAGNOSTICS rather than CONFIG MENU.

The Event Log printed from DIAGNOSTICS includes:

- Detailed printer information, including code versions
- Time and date stamps
- Page counts for most errors

- Additional debug information in some cases

**Event Log** (Page 1)  
**Lexmark T642 (sn:xxxxxxxx)**

**Device Information**

Page Count: 10  
 Processor Type: T20 MB  
 Processor Speed: 440MHz  
 Engine: LF-ST-F04B-g0  
 Loader: LF-ST-F04B-g0  
 Network: LF-ST-F04B-g0  
 Base: WF-40-4040B-g0  
 Network Driver: LF-ST-F04B-g0  
 Font: R1100T-04-4

**Event Log Information**

**BY Sheet**

Panel Message: Restoring Factory Defaults  
 Page Count: 10  
 Date and Time: Thu Jan 01 00:00:00 1970  
 ID File: 09\_sata\_T63\_memo

**Code Levels**

Target: 0001\_000  
 0) Loader-LF-ST-F04B-g0 Wed Jan 5 16:49:37 2004 wta-010  
 1) Service-LF-ST-F04B-g0 Wed Jan 5 16:49:37 2004 wta-010  
 2) Base-LF-ST-F04B-g0 Wed Jan 5 16:49:37 2004 wta-010  
 3) Network-WF-40-4040B Wed Jan 5 16:49:37 2004 wta-010  
 4) Network-WF-40-4040B Wed Jan 5 16:49:37 2004 wta-010  
 5) Network-WF-40-4040B Wed Jan 5 16:49:37 2004 wta-010  
 6) Network-WF-40-4040B Wed Jan 5 16:49:37 2004 wta-010  
 7) Network-WF-40-4040B Wed Jan 5 16:49:37 2004 wta-010  
 8) Network-WF-40-4040B Wed Jan 5 16:49:37 2004 wta-010  
 9) Network-WF-40-4040B Wed Jan 5 16:49:37 2004 wta-010  
 10) Network-WF-40-4040B Wed Jan 5 16:49:37 2004 wta-010  
 11) Network-WF-40-4040B Wed Jan 5 16:49:37 2004 wta-010  
 12) Network-WF-40-4040B Wed Jan 5 16:49:37 2004 wta-010  
 13) Network-WF-40-4040B Wed Jan 5 16:49:37 2004 wta-010  
 14) Network-WF-40-4040B Wed Jan 5 16:49:37 2004 wta-010  
 15) Network-WF-40-4040B Wed Jan 5 16:49:37 2004 wta-010  
 16) Network-WF-40-4040B Wed Jan 5 16:49:37 2004 wta-010  
 17) Network-WF-40-4040B Wed Jan 5 16:49:37 2004 wta-010  
 18) Network-WF-40-4040B Wed Jan 5 16:49:37 2004 wta-010  
 19) Network-WF-40-4040B Wed Jan 5 16:49:37 2004 wta-010  
 20) Network-WF-40-4040B Wed Jan 5 16:49:37 2004 wta-010  
 21) Network-WF-40-4040B Wed Jan 5 16:49:37 2004 wta-010  
 22) Network-WF-40-4040B Wed Jan 5 16:49:37 2004 wta-010  
 23) Network-WF-40-4040B Wed Jan 5 16:49:37 2004 wta-010  
 24) Network-WF-40-4040B Wed Jan 5 16:49:37 2004 wta-010  
 25) Network-WF-40-4040B Wed Jan 5 16:49:37 2004 wta-010  
 26) Network-WF-40-4040B Wed Jan 5 16:49:37 2004 wta-010  
 27) Network-WF-40-4040B Wed Jan 5 16:49:37 2004 wta-010  
 28) Network-WF-40-4040B Wed Jan 5 16:49:37 2004 wta-010  
 29) Network-WF-40-4040B Wed Jan 5 16:49:37 2004 wta-010  
 30) Network-WF-40-4040B Wed Jan 5 16:49:37 2004 wta-010  
 31) Network-WF-40-4040B Wed Jan 5 16:49:37 2004 wta-010

**RIP Service - RIP Software**

Panel Message: RIP Software Process m32rapp195 caught 010000v wdt  
 Page Count: 0  
 Date and Time: Thu Jan 01 00:00:00 1970  
 ID File: 09\_sata\_T63\_memo

**Code Levels**

Target: 0001\_000  
 0) Loader-LF-ST-F04B-g0 Tue Dec 21 16:17:41 2004 wta-010  
 1) Service-LF-ST-F04B-g0 Tue Dec 21 16:17:41 2004 wta-010  
 2) Base-LF-ST-F04B-g0 Tue Dec 21 16:17:41 2004 wta-010  
 3) Network-WF-40-4040B Tue Dec 21 16:17:41 2004 wta-010  
 4) Network-WF-40-4040B Tue Dec 21 16:17:41 2004 wta-010  
 5) Network-WF-40-4040B Tue Dec 21 16:17:41 2004 wta-010  
 6) Network-WF-40-4040B Tue Dec 21 16:17:41 2004 wta-010  
 7) Network-WF-40-4040B Tue Dec 21 16:17:41 2004 wta-010  
 8) Network-WF-40-4040B Tue Dec 21 16:17:41 2004 wta-010  
 9) Network-WF-40-4040B Tue Dec 21 16:17:41 2004 wta-010  
 10) Network-WF-40-4040B Tue Dec 21 16:17:41 2004 wta-010  
 11) Network-WF-40-4040B Tue Dec 21 16:17:41 2004 wta-010  
 12) Network-WF-40-4040B Tue Dec 21 16:17:41 2004 wta-010  
 13) Network-WF-40-4040B Tue Dec 21 16:17:41 2004 wta-010  
 14) Network-WF-40-4040B Tue Dec 21 16:17:41 2004 wta-010  
 15) Network-WF-40-4040B Tue Dec 21 16:17:41 2004 wta-010  
 16) Network-WF-40-4040B Tue Dec 21 16:17:41 2004 wta-010  
 17) Network-WF-40-4040B Tue Dec 21 16:17:41 2004 wta-010  
 18) Network-WF-40-4040B Tue Dec 21 16:17:41 2004 wta-010  
 19) Network-WF-40-4040B Tue Dec 21 16:17:41 2004 wta-010  
 20) Network-WF-40-4040B Tue Dec 21 16:17:41 2004 wta-010  
 21) Network-WF-40-4040B Tue Dec 21 16:17:41 2004 wta-010  
 22) Network-WF-40-4040B Tue Dec 21 16:17:41 2004 wta-010  
 23) Network-WF-40-4040B Tue Dec 21 16:17:41 2004 wta-010  
 24) Network-WF-40-4040B Tue Dec 21 16:17:41 2004 wta-010  
 25) Network-WF-40-4040B Tue Dec 21 16:17:41 2004 wta-010  
 26) Network-WF-40-4040B Tue Dec 21 16:17:41 2004 wta-010  
 27) Network-WF-40-4040B Tue Dec 21 16:17:41 2004 wta-010  
 28) Network-WF-40-4040B Tue Dec 21 16:17:41 2004 wta-010  
 29) Network-WF-40-4040B Tue Dec 21 16:17:41 2004 wta-010  
 30) Network-WF-40-4040B Tue Dec 21 16:17:41 2004 wta-010  
 31) Network-WF-40-4040B Tue Dec 21 16:17:41 2004 wta-010

The printed event log can be faxed to Lexmark or your next level of support for verification or diagnosis.

To print the event log:

Select **Print Log** from EVENT LOG.

Press **Back**  to return to EVENT LOG.

### Clear Log

Use Clear Log to remove the current information in the Event Log. This affects both the viewed log and the printed log information.

1. Select **Clear Log** from the Event Log menu.
2. Select **YES** to clear the Event Log or **NO** to exit the Clear Log menu. If **YES** is selected, **Deleting EVENT LOG** displays on the screen.

Press **Back**  to return to EVENT LOG.



### EXIT DIAGNOSTICS (models T650, T652, and T654)

This selection exits Diagnostics mode, and **Resetting the Printer** displays. The printer performs a POR, and the printer returns to normal mode.



## Configuration menu (CONFIG MENU) (models T650, T652, and T654)

### Entering Configuration Menu (models T650, T652, and T654)

1. Turn off the printer.
2. Press and hold  and .
3. Turn on the printer.
4. Release the buttons after ten seconds.

The message **CONFIG MENU** displays on the top line of the operator panel.

### Available menus

Maint Cnt Value	See <b>“Maintenance page count (Maint Cnt Value)”</b> on page 3-25
Reset Cnt	See <b>“Maintenance page counter reset (Reset Cnt)”</b> on page 3-26
Prt Quality Pgs	See <b>“Print quality pages (Prt Quality Pgs)”</b> on page 3-26
Reports	See <b>“Reports”</b> on page 3-26.
SIZE SENSING	See <b>“SIZE SENSING”</b> on page 3-27
Panel Menus	See <b>“Panel Menus”</b> on page 3-27
PPDS Emulation	See <b>“PPDS Emulation”</b> on page 3-27
Demo Mode	See <b>“Demo Mode”</b> on page 3-27
Factory Defaults	See <b>“Factory Defaults”</b> on page 3-28
LES Applications	See <b>“LES Applications”</b> on page 3-28
Energy Conserve	See <b>“Energy Conserve”</b> on page 3-28
Paper Prompts	See <b>“Paper Prompts”</b> on page 3-28
Env Prompts	See <b>“Env Prompts”</b> on page 3-28
Action for Prompts	See <b>“Action for Prompts”</b> on page 3-28
Font Sharpening	See <b>“Font Sharpening”</b> on page 3-28
Wiper Messages	See <b>“Wiper Messages”</b> on page 3-28
Clear Custom Status	See <b>“Clear Custom Status”</b> on page 3-28
Best Speed	See <b>“Best Speed”</b> on page 3-29
Exit Config Menu	

Some menus are not available, depending on the configuration of the printer.

### Maintenance page count (Maint Cnt Value)

The current value for the maintenance page counter is displayed. This counter tracks printer usage. A print job containing a single page increments the counter by one and a duplex page by two. At 300,000, the customer is reminded that the printer requires scheduled maintenance. This counter is reset by the servicer after an 80 Scheduled Maintenance message displays, and a maintenance kit is installed. See **“Maintenance kit”** on page 6-2 for the part number.

To view the maintenance page count:

1. Select **Maint Cnt Value** from CONFIG MENU.
2. Press  to view the value.

Press **Back**  to return to the main Configuration menu.

### ***Maintenance page counter reset (Reset Cnt)***

After scheduled maintenance, the servicer needs to reset the page counter.

To reset the maintenance page count to zero:

Select **Reset Cnt** from the Configuration menu, and then select **Reset**.

When the reset operation is complete, the display returns to the Configuration menu.

### ***Print quality pages (Prt Quality Pgs)***

The print quality test pages can be printed from either the Diagnostics mode or Configuration Menu (CONFIG MENU). When printed from the Diagnostic mode, additional information is included, and the print cartridge lockout is bypassed. See **“Print quality pages (Prt Quality Pgs)” on page 3-7**.

To print the Print Quality Test Pages, select **Prt Quality Pgs** from CONFIG MENU. The message **Printing Quality Test Pages** is displayed.

The following is included in the CONFIG MENU version of the first print quality test page:

- Device information
- Printer revision levels
- Cartridge information
- Printer margin settings
- Minimum stroke width

The print quality test consist of four pages. Page one contains a mixture of graphics and text. Page two is gray with two one inch black squares located on the bottom right. Page three is solid black page and page four is blank. If duplex is turned on, the pages are duplexed. The Print Quality Test pages are printed in English and must always be printed on letter, legal, or A4 paper.

### ***Reports***

Two different reports can be printed from this menu:

Menu Settings Page

Event log

To print the Menu Settings Page, select **Reports** from CONFIG MENU, and then **Menu Settings Page**. The message **Printing Menu Settings Page** is displayed. The printed report contains:

- Reset Cnt
- Reports
- SIZE SENSING
- Factory Defaults
- Debug Information

To print the Event Log, select **Reports** from CONFIG MENU, and then **Event Log**. The message **Printing EVENT LOG** is displayed. The event log provides a history of printer errors. The event log can only be printed in CONFIG MENU.

## SIZE SENSING

This setting controls whether the printer automatically registers the size of paper installed in an input source with size sensing.

Paper source	Size sensing
Tray 1 (integrated)	X
Multipurpose feeder	
250-sheet drawer	X
550-sheet drawer	X
High Capacity Feeder	X
Envelope feeder	

When the setting is Auto, every input option equipped with size sensing hardware automatically registers what size media it contains. When the setting is Off, the media size detected by hardware is ignored. The media size can be set by the operator panel or the data stream.

To change the size sensing setting:

1. Select **SIZE SENSING** from the Configuration menu.
2. Select **Auto** or **Off**, and press .

Press **Back**  to exit.

## Panel Menus

Settings are **Disable** and **Enable**. The default is Enable.

## PPDS Emulation

This menu item allows the user to enable or disable PPDS emulation data stream. When this setting is enabled, the following settings are also changed:

- SmartSwitch settings for each port are turned off.
- The printer language is changed to PPDS Emulation.

Users can still switch languages on the operator panel and through the PJL data stream.

## Demo Mode

There is a built-in demonstration mode. The settings allow you to **Deactivate** to turn off the demo mode and **Activate** to turn it on. While Demo Mode is set, the printer will start in Demo Mode until you change the setting.

**WARNING:** While Demo Mode is set to **Activate**, only demonstration files can print, and files received across the network or from the host computer are ignored.

## Factory Defaults

This setting enables a user to restore all the printer settings to the original factory settings. Selections are **Restore Base** and **Restore Network**. Network does not appear unless you have a network printer. The following settings are not changed:

- Display language
- Settings in the NETWORK/PORTS MENU group.

## LES Applications

This disables all installed Lexmark Embedded Solution applications.

Settings are **Disable** and **Enable**. The default is Enable.

## Energy Conserve

This menu controls what values appear on the Power Saver menu. If **Off** is selected in Energy Conserve menu, then Disabled appears in the Power Saver menu and Power Saver can be turned off. If **On** is set in Energy Conserve, the Power Saver feature cannot be disabled.

## Paper Prompts

When a tray is out of the indicated paper size, a prompt is sent to the user to load paper in a tray. This setting controls the tray the user is directed to fill. Selections are **Auto** (default), **MP Feeder**, and **Manual Paper**.

## Env Prompts

This setting controls the tray the user is directed to refill when specific envelope size is out. The selections are **Auto** (default), **MP Feeder**, **Envelope Feeder**, and **Manual Env**.

## Action for Prompts

The three settings are **Prompt user**, **Continue**, or **Use current**. Make a setting change, and the press . **Submitting selection** appears on the display.

## Font Sharpening

The settings range from 0 to 150. The default is 24. Make a setting change, and then press . **Submitting selection** appears on the display.

## Wiper Messages

Settings are **On** and **Off**. The default is **On**. Make a setting change, and then press . **Submitting selection** appears on the display.

## Clear Custom Status

No values exist for this operation. Pressing  initiates this operation.

**Note:** Executing this operation erases any strings that have been defined by the user for the default or alternate custom messages.

### Best Speed

Settings are **For short jobs** and **For long jobs**. Make a setting change, and then press . **Submitting selection** appears on the display.

### Exit Config Menu (models T650, T652, and T654)

Press  to exit the CONFIG MENU. The message **Resetting the Printer** displays, and the printer performs a POR and restarts in normal mode.

## Understanding the printer control panel (model T656)

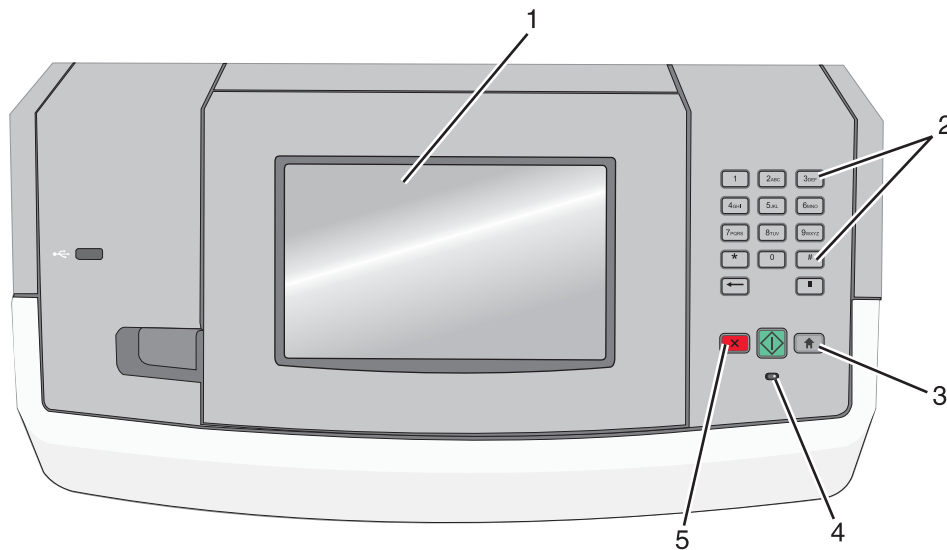



Item	Description
1	Display
2	Keypad
3	Home

View printing options as well as status and error messages.

Enter numbers or symbols on the display.

Press  to return to the home screen.







Item		Description
4	Indicator light	Indicates the printer status: <ul style="list-style-type: none"> <li>• Off—The power is off.</li> <li>• Blinking green—The printer is warming up, processing data, or printing.</li> <li>• Solid green—The printer is on, but idle.</li> <li>• Blinking red—Operator intervention is needed.</li> </ul>
5	Stop  	Stops all printer activity A list of options is offered once <b>Stopped</b> appears on the display.

## Accessing service menus (model T656)

There are different test menus that can be accessed during POR to identify problems with the printer.

<p><b>Diagnostics Menu</b></p> 	<ol style="list-style-type: none"> <li>1. Turn off the printer.</li> <li>2. Press and hold the <b>3</b> and <b>6</b> buttons simultaneously for about 10 seconds.</li> <li>3. Turn on the printer.</li> <li>4. Release the buttons after 10 seconds.</li> </ol>	<p>The Diagnostics Menu group consists of menus, settings, and operations that are used to diagnose various printer problems.</p> <p><b>Note:</b> While the Diagnostics menu group is active, all host interfaces are offline.</p> <p>See <b>“Entering Diagnostics Menu (model T656)” on page 3-31</b> for more information.</p>
<p><b>Configuration Menu</b></p> 	<ol style="list-style-type: none"> <li>1. Turn off the printer.</li> <li>2. Press and hold the <b>2</b> and <b>6</b> buttons simultaneously for about 10 seconds.</li> <li>3. Turn on the printer.</li> <li>4. Release the buttons after 10 seconds.</li> </ol>	<p>The Configuration Menu group contains a set of menus, settings, and operations which are infrequently required by a user. Generally, the options made available in this menu group are used to configure a printer for operation.</p> <p>See <b>“Configuration menu (CONFIG MENU) (model T656)” on page 3-49</b> for more information.</p>

## Diagnosics Menu (model T656)

### Entering Diagnostics Menu (model T656)

1. Turn off the printer.
2. Press and hold **3** and **6** buttons simultaneously.
3. Turn on the printer.
4. Release the buttons after 10 seconds.

### Available tests

The tests display on the operator panel in the order shown:

**Note:** Some menus are not available, depending on the configuration of the printer.

#### Diagnosics Menu tests

<b>REGISTRATION</b>	See <b>“Registration (printer)”</b> on page 3-33
Top Margin	
Bottom Margin	
Left Margin	
Right Margin	
Quick Test	See <b>“Quick Test”</b> on page 3-34
<b>PRINT TESTS</b>	See <b>“PRINT TESTS”</b> on page 3-35
Tray 1	
Tray 2 (if installed)	
Tray 3 (if installed)	
Tray 4 (if installed)	
Tray 5 (if installed)	
MP Feeder	
Envelopes - MP Feeder (if installed)	
Printing Quality Pages	See <b>“Printing Quality Pages”</b> on page 3-35
<b>HARDWARE TEST</b>	See <b>“HARDWARE TESTS”</b> on page 3-36
Panel Test	See <b>“Panel Test”</b> on page 3-36
Button Test	See <b>“Button Test”</b> on page 3-36
DRAM Test	See <b>“DRAM Test”</b> on page 3-37
USB HS Test Mode	See <b>“USB HS Test Mode”</b> on page 3-37
<b>DUPLEX TESTS (if installed)</b>	See <b>“DUPLEX TESTS”</b> on page 3-38
Quick Test	See <b>“Quick Test (duplex)”</b> on page 3-38
Top Margin	See <b>“Top Margin (duplex)”</b> on page 3-38
Sensor Test	See <b>“Sensor Test (duplex)”</b> on page 3-39
Motor Test	See <b>“Motor Test (duplex)”</b> on page 3-39
Duplex Feed 1	See <b>“Duplex Feed 1”</b> on page 3-40
Duplex Feed 2	See <b>“Duplex Feed 2”</b> on page 3-40
<b>INPUT TRAY TESTS</b>	See <b>“INPUT TRAY TESTS”</b> on page 3-40
Feed Tests	See <b>“Feed Tests (input tray)”</b> on page 3-40

**Diagnostics Menu tests (Continued)**

Tray 1	
Tray 2 (if installed)	
Tray 3 (if installed)	
Tray 4 (if installed)	
Tray 5 (if installed)	
Envelope Feeder	
MP Feeder	
Sensor Tests	See <b>“Sensor Test (input tray)” on page 3-41</b>
Tray 1	
Tray 2 (if installed)	
Tray 3 (if installed)	
Tray 4 (if installed)	
Tray 5 (if installed)	
Envelope Feeder	
MP Feeder	
<b>OUTPUT BIN TESTS</b>	See <b>“OUTPUT BIN TESTS” on page 3-41</b>
Feed Tests	
Standard Bin	
Sensor Tests	
Standard Bin	
<b>BASE SENSOR TEST</b>	See <b>“BASE SENSOR TEST” on page 3-42</b>
Toner Sensor	
Input Sensor	
Output Sensor	
NarrowMedia	
Front Door	
<b>DEVICE TESTS</b>	See <b>“DEVICE TESTS” on page 3-43</b>
Quick Disk Test	See <b>“Quick Disk Test” on page 3-43</b>
Disk Test/Clean	See <b>“Quick Disk Test” on page 3-43</b>
<b>PRINTER SETUP</b>	See <b>“PRINTER SETUP” on page 3-44</b>
Defaults	See <b>“Defaults” on page 3-44</b>
Printed Page Count	See <b>“Printed Page Count” on page 3-44</b>
Perm Page Count	See <b>“Permanent Page Count” on page 3-44</b>
Serial Number	See <b>“Serial Number” on page 3-44</b>
Engine Settings 1 through 16	See <b>“Engine Settings 1 through 16” on page 3-44</b>
Model Name	See <b>“Model Name” on page 3-44</b>
Configuration ID	See <b>“Configuration ID” on page 3-45</b>
Edge To Edge	See <b>“Edge to Edge” on page 3-45</b>
<b>EP SETUP</b>	See <b>“EP SETUP” on page 3-45</b>
EP Defaults	See <b>“EP Defaults” on page 3-46</b>
Fuser Temp	See <b>“Fuser Temperature (Fuser Temp)” on page 3-46</b>
Fuser Page Count	See <b>“Fuser Page Count” on page 3-46</b>



**Diagnostics Menu tests (Continued)**

Warm Up Time	See <b>“Warm Up Time”</b> on page 3-46
Transfer	See <b>“Transfer”</b> on page 3-46
Print Contrast	See <b>“Print Contrast”</b> on page 3-46
Charge Roll	See <b>“Charge Roll”</b> on page 3-46
Gap Adjust	See <b>“Gap Adjust”</b> on page 3-47
Auto Dark Adjust	See <b>“Auto Dark Adjust”</b> on page 3-47
<b>REPORTS</b>	See <b>“REPORTS”</b> on page 3-47
Menu Settings Page	See <b>“Menu Settings Page”</b> on page 3-47
<b>EVENT LOG</b>	See <b>“EVENT LOG”</b> on page 3-47
Display Log	See <b>“Display Log”</b> on page 3-47
Print Log	See <b>“Print Log”</b> on page 3-48
Clear Log	See <b>“Clear Log”</b> on page 3-48

Touch **Exit Diag Menu** to exit the Diagnostics Menu, and **Resetting the Printer** displays. The printer performs a POR, and the printer returns to ready mode.

**Exit  
Diag Menu**

**Registration (printer)**

Print registration makes sure the printing is properly aligned on the page.

REGISTRATION

Top Margin 0

Bottom Margin 0

Left Margin 0

Right Margin 0

Quick Test

Submit Back

The settings available are:

Description	Value	Direction of change
Top Margin	-25 to +25 Each increment causes approximately 4 pels shift (at 600 dpi).	A positive change moves the image down the page and increases the top margin. A negative change moves the image up and decreases the top margin.
Bottom Margin	-20 to +20 Each increment causes approximately 0.55 mm shift in the bottom margin.	A positive change compresses the image so it appears to move down the page, and a negative change moves the image up.

Description	Value	Direction of change
Left Margin	-25 to +25	A positive change moves the image right, and a negative change moves the image left. No compression occurs.
Right Margin	-10 to +10	A positive change moves the image right, and a negative change moves the image left.

To set print registration:

1. Print the Quick Test page.



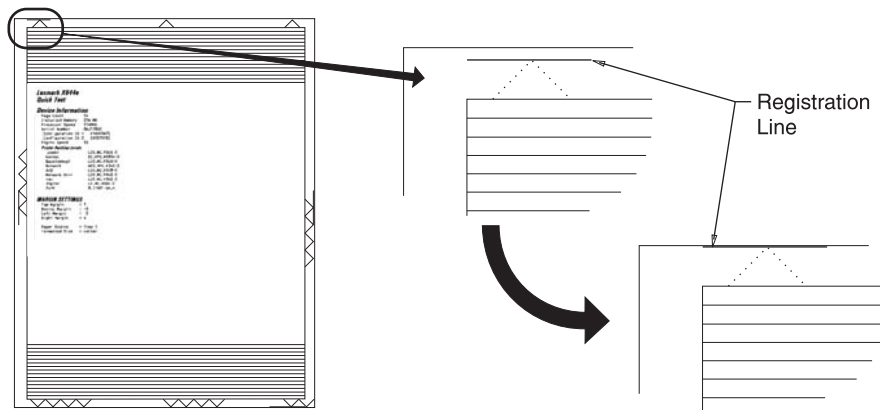

**a.** Touch **REGISTRATION** from the Diagnostics Menu.

**b.** Touch  to select Quick Test. You may need to scroll to the next page.

Retain this page to determine the changes you need to make to the margins settings. The diamonds in the margins should touch the margins of the page.



2. To change the value of any of the margin settings:

- Touch  to the right of the appropriate margin setting. The panel displays the setting's name in the header and  [setting's current value]  in a menu below the header row.
- Touch  to decrease the value or  to increase the value.
- Touch **Submit** to save the change, or Touch **Back** to cancel and return to the Diagnostics Menu.
- Touch **Submit** to save all changed values.

The device prints a Quick Test page from the appropriate paper tray. While the Quick Test page prints, **Printing Alignment Page** appears on the LCD.

## Quick Test

The Quick Test contains the following information:

- Device information
- Printer margin settings
- Alignment diamonds at the top, bottom, and each side.
- Horizontal lines for skew adjustment
- General printer information, including current page count, installed memory, processor speed, serial number, Engine ID, and system card ID.

To print the Quick Test page:

**Note:** Print the Quick Test Page on letter or A4 paper.

1. Touch **REGISTRATION** from the Diagnostics Menu.
2. Touch  to select Quick Test.

The message **Quick Test Printing...** appears on the display.

Once the Quick Test Page completes printing, the Registration screen displays again.

3. Touch **Back** to return to the Diagnostics Menu.

## PRINT TESTS

Selections on the screen vary since only installed input sources are listed, followed by Printing Quality Test Pages.

### Input source tests

The purpose of the diagnostic Print Tests is to verify that the printer can print on media from each of the installed input options. The contents of the Print Test Page varies depending on the media installed in the selected input source.

Check each Test Page from each source to assist in print quality and paper feed problems.

To run the Print Test Page:

1. Select **PRINT TESTS** from the Diagnostics menu.
2. Select the media source to test:
  - Tray 1
  - Tray 2 (if installed)
  - Tray 3 (if installed)
  - Tray 4 (if installed)
  - Tray 5 (if installed)
  - Multi-Purpose Feeder (if installed)
  - Envelope Feeder (if installed)
3. Select **Single** or **Continuous**.
  - If **Single** is selected, a single page is printed.
  - If **Continuous** is selected, printing continues until **Stop** is pressed to cancel the test.
    - If a source is selected that contains envelopes, an envelope test pattern is printed. If Continuous is selected, the test pattern is printed only on the first envelope.

**Note:** The Print Test Page always prints on one side of the paper, regardless of the duplex setting or the presence of a duplex option.

Touch **Back** to return to PRINT TESTS.

### Printing Quality Pages

The purpose of this diagnostic function is to allow printing of the print quality test pages with the toner cartridge lockout function disabled. The print quality pages consist of four pages. Page one contains a mixture of graphics and text. Page two is gray with two one-inch black squares located on the bottom right. Page three is a solid black page and page four is blank. If duplex is turned on, the pages are duplexed. The Print Quality Test pages are printed in English and must always be printed on letter, legal, or A4 paper.

To run the Print Quality Test Pages, touch ➡ beside Printing Quality Test Pages from PRINT TESTS. The message **Printing Quality Test Pages** is displayed.

**Note:** The print quality test pages can also be printed from the Configuration menu (CONFIG MENU), however, a cartridge must be installed with a machine class ID matching the machine class ID stored in NVRAM. Additional diagnostic information may be printed on the pages when printing from DIAGNOSTICS.

The following is included in the DIAGNOSTICS version of the print quality pages:

- Values from EP SETUP in DIAGNOSTICS, including:
  - Fuser temperature, warm-up time, transfer, print contrast, charge roll settings and gap adjust.

- Contents of the EVENT LOG from DIAGNOSTICS.
- Configuration information, including printer serial number, controller code level, engine code level, operator panel code level, font versions, and cartridge information.
- Default values for the QUALITY MENU settings used to print the pages.

## HARDWARE TESTS

Select the following Hardware Tests from this menu:

- Panel Test
- Button Test
- DRAM Test
- USB HS Test Mode

### Panel Test

This test automatically toggles each pixel of the touchscreen through every contrast level beginning with the darkest and on to the brightest. This test continues until you press **Stop** .

### Button Test

The Button Test verifies the operation of the buttons on the operator panel. When you select Button Test, a diagram of the operator panel appears on the panel. When you press a button on the operator panel, the corresponding touchscreen key is emphasized. Touch **Back** to cancel the test.

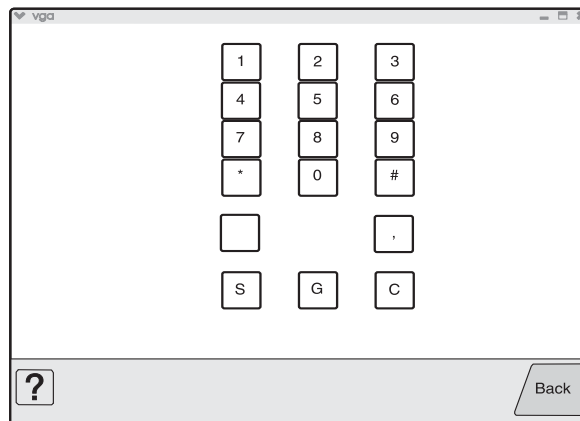

## DRAM Test

The purpose of this test is to check the validity of DRAM memory, both standard and optional. The test writes patterns of data to DRAM to verify that each bit in memory can be set and read correctly.

To run the DRAM Test:

1. Touch  to select DRAM Test from the menu.  
The message **DRAM Test Testing...** displays. Then the message **Resetting Printer** appears, and the power indicator light *blinks* red.
2. Turn the printer off and on. While the DRAM test executes, the power indicator *blinks* green.  
The following type of message appears:

**DRAM Test <###      P:#####      F:####**





- xxx represents the installed DRAM size.
- P:##### represents the number of times the memory test has passed and finished successfully. Initially 000000 displays with the maximum pass count being 999,999.
- F:#### represents the number of times the memory test has failed and finished with errors. Initially 0000 displays with the maximum fail count being 99,999. Initially only four digits appear, but additional digits appear as needed.

Each time a test is completed, the number of pass and failures increments. If the test fails, the message **Failure** displays for approximately three seconds, and the failure count increases by one.

The test continues until all standard and optional DRAM is tested. Once the maximum pass count or fail count is reached, the test is stopped, the power indicator is turned on solid, and the final results display.

To stop the test before completion, turn the MFP off.

## USB HS Test Mode

1. Select **USB HS Test Mode** from HARDWARE TESTS.
2. Press  until the  appears next to the Port to be tested, and then press .
3. Select the desired Test, and then press .

Port	Test	Appears on the display
Port 0	Test J Test K Test SEO NAK Test Packet Test Force Enabled	<b>USB High Speed Certification Testing...</b>
Port 1	Test J Test K Test SEO NAK Test Packet Test Force Enabled	<b>USB High Speed Certification Testing...</b>
Port 2	Test J Test K Test SEO NAK Test Packet Test Force Enabled	<b>USB High Speed Certification Testing...</b>
Port 3	Test J Test K Test SEO NAK Test Packet Test Force Enabled	<b>USB High Speed Certification Testing...</b>

Port	Test	Appears on the display
Single Step Get Device Descriptor		USB High Speed Certification Testing...
Single Step Set Feature		USB High Speed Certification Testing...

To stop testing before completion, turn the printer off.

## DUPLEX TESTS



### Quick Test (duplex)

This test prints a duplex version of the Quick Test that can be used to verify that the correct placement of the top margin on the back side of a duplex page. You can run one duplexed page (**Single**), or continue printing duplexed pages (**Continuous**) until **Stop**  is pressed. For information about changing the margin, see **“Top Margin (duplex)” on page 3-13**.

**Note:** Before you set the duplex top margin, be sure to set the registration. See **“REGISTRATION” on page 3-5**.

The paper you choose to print the page on should be either Letter or A4.

To run the Quick Test (duplex):

1. Touch  to select **Quick Test** from DUPLEX TESTS.
2. Touch  to select **Single** or **Continuous**.
  - The single Duplex Quick test cannot be canceled.
  - The printer attempts to print the Quick Test Page from the default paper source. If the default paper source only supports envelopes, then the page is printed from Tray 1.
  - Check the Quick Test Page for the correct offset between the placement of the first scan line on the front and back side of a duplexed sheet.



The single test stops automatically when a single duplex sheet is printed, and the continuous test continues until you press **Stop** .

### Top Margin (duplex)

This setting controls the offset between the first scan line on the front of the duplex page and the first scan line on the back of the page. Therefore, be sure to set the top margin in REGISTRATION before setting the duplex top margin. See **“REGISTRATION” on page 3-5**.

To set the Top Margin (duplex):

1. Print the Quick Test (duplex):
  - a. Touch  to select **Quick Test** from DUPLEX TESTS.
  - b. Select **Single**.
  - c. Hold the page to the light to see the whether the top margin of the backside aligns with the top margin of the front side.
2. Select **Top Margin** from DUPLEX TESTS.
3. Use the arrows to increase or decrease the current setting displayed on the touchscreen to select the margin setting:

 [setting's current value] .

  - Each increment shifts the duplex top margin by 1/100 of an inch.
  - The Top Margin (duplex) range is -25 to +25, and the default value is 0.

- An increase moves the top margin down and widens the top margin. A decrease moves the top margin upward and narrows the top margin.
4. Touch **Submit**.
  5. Print the Quick Test (duplex) again to verify the adjustment. Repeat if necessary.

### Left Margin (duplex)

To set the Left Margin (duplex):

1. Print the Quick Test (duplex):
  - a. Touch  to select **Quick Test** from DUPLEX TESTS.
  - b. Select **Single**.
  - c. Hold the page to the light to see the whether the top margin of the backside aligns with the top margin of the front side.
2. Select **Left Margin** from DUPLEX TESTS.
3. Use the arrows to increase or decrease the current setting displayed on the touchscreen to select the margin setting:
 

◀ [setting's current value] ▶

  - Each increment shifts the duplex left margin by 1/100 of an inch.
  - The Left Margin (duplex) range is -25 to +25, and the default value is 0.
  - An increase moves the left margin to the right and widens the left margin. A decrease moves the left margin to the left and narrows the left margin.
4. Touch **Submit**.
5. Print the Quick Test (duplex) again to verify the adjustment. Repeat if necessary.

### Sensor Test (duplex)

This test is used to determine whether or not the duplex sensors and switches are working correctly. The test allows you to actuate the duplex input sensor located in the back part of the duplex unit and the duplex exit sensor located in the return paper path.

1. Select **Sensor Test** from DUPLEX TESTS.  
The message **Sensor Test Testing** displays.
2. Manually actuate each of the duplex sensors. When the sensor/switch is closed, **CL** (closed) displays, and when the sensor/switch is open, **OP** (open) displays.
  - Duplex input sensor
  - Duplex exit sensor
3. Press **Stop**  to exit the test.

### Motor Test (duplex)

This test lets you test the duplex option paper feed drive system, and verify that the power and velocity values are acceptable. The duplex runs the DC motor at high speed and low speed, taking an average of the power (PWM) required for each speed and calculating the KE value.

To run the Motor Test (duplex):

1. Select **Motor Test** from DUPLEX TESTS.  
The power indicator light *blinks*, and the message **Motor Test Testing** displays.

- When the motor stops, the results are displayed. Listed below is an example of such results:



```
Duplex Motor Test Test Passed
Avg. PWM of High-Speed Test: 1d
Avg. PWM of Low-Speed Test: 0e
Max. PWM of Low-Speed Test: 00
Min. PWM of Low-Speed Test: 0b
Motor KE Value: 2d
Motor Test Results: 00
```

- Touch **Back** or press **Stop**  to exit the test.

## Duplex Feed 1

This test feeds a blank sheet of paper to the duplex paper stop position 1. This test can be run using any of the supported paper sizes.



To run the Duplex Feed 1 Test:

- Touch  to select **Duplex Feed 1** from DUPLEX TESTS.  
The power indicator blinks while the paper is feeding, and the message **Duplex Feed 1 Feeding...** displays.  
The message **Duplex Feed 1 Clear Paper** displays when the paper reaches paper stop position 1, and the power indicator turns on solid.
- Remove the media from the duplex unit, and clear the message on the operator panel by pressing **Stop** .

## Duplex Feed 2

This test feeds a blank sheet of paper to the duplex paper stop position 2. This test can be run using any of the supported paper sizes.

To run the Duplex Feed 2 Test:





- Touch  to select **Duplex Feed 2** from DUPLEX TESTS.  
The power indicator blinks while the paper is feeding, and the message **Duplex Feed 2 Feeding...** displays.  
The message **Duplex Feed 2 Clear Paper** displays when the paper reaches the duplex paper stop position 2, and the power indicator turns on solid.
- Remove the media from the duplex unit, and clear the message on the operator panel by touching **Back** or pressing **Stop** .

## INPUT TRAY TESTS

### Feed Tests (input tray)

This test lets the servicer observe the paper path as media is feeding through the printer. A blank sheet of paper feeds through the printer as the laser turns off during this test. The only way to observe the paper path is to open the lower front door that is used to access the envelope or multipurpose feeder. The paper is placed in the output bin.



To run the Input Tray Feed Tests:

- Touch  to select **Feed Tests** from INPUT TRAY TESTS.
- Touch  to select the input source from the sources displayed on the Feed Tests menu. All installed sources are listed.
- Touch  to select either Single or Continuous.
  - Single**—feeds one sheet of media from the selected source.
  - Continuous**—media continues feeding from the selected source until **Stop**  is pressed.



## Sensor Test (input tray)

This test is used to determine if the input tray sensors are working correctly. To run the Input Tray Sensor Test:

1. Touch  to select the **Sensor Test** from INPUT TRAY TESTS.
2. Touch  to select the input source from the sources displayed on the Sensor Test menu. All installed sources are listed.
3. Select the sensor to test. Various sources have different combinations of sensors. See the table below:

### Tray sensor support by source

Source	Empty (Input tray empty sensor)	Low (Input tray paper low sensor)	passThru (Input tray pass thru sensor)
Tray 1	X	X	
Tray 2	X	X	X
Tray 3	X	X	X
Tray 4	X	X	X
Tray 5	X	X	X
Multipurpose tray	X		
Envelope feeder	X		

[*sensor selected*]=**Open** displays.





- Empty—Input tray empty sensor
  - Low—Input tray paper low sensor
  - passThru—Input tray pass thru sensor
4. Once this message displays, the servicer can manually actuate each sensor. The tray empty sensor can be actuated by hand, however a sheet of paper can be used to cover the pass thru sensor. When the sensor is closed, **closed** displays; when the sensor is open, **open** displays.
  5. Press **Stop**  to exit the test.

## OUTPUT BIN TESTS

### Feed Tests (output bins)

Use these tests to verify that media can be fed to the standard output bin. No information is printed on the media fed to the output bin, because the printhead is not engaged during this test. These tests can use any media size or envelope supported by the printer.

To run the Feed Tests for the output bins:



1. Touch  to select **Feed Tests** from the OUTPUT BIN TESTS.
2. Touch  to select the output bin you want the paper to exit into.
3. Touch  to select either Single or Continuous.
  - **Single**—feeds one sheet of media from the selected source.
  - **Continuous**—media continues feeding from the selected source until **Stop**  is pressed.

Touch **Back** to return to OUTPUT BIN TESTS.

### Sensor Test (standard output bin)

This test is used to verify if the standard bin sensor is working correctly.

To run the Sensor Test for the standard bin:

1. Touch  to select **Sensor Test** from OUTPUT BIN TESTS.
2. Touch  to select **Standard Bin** from Sensor Tests.
3. Manually actuate the bin sensor by moving the flag in and out of the sensor, and the display changes.  
The following screen is displayed:  
**Bin Empty: empty** or **Bin Empty: full**.
4. Press **Stop**  to exit the test.

## **BASE SENSOR TEST**

This test is used to determine if the sensors located inside the printer are working correctly.

To run the Base Sensor Test:



1. Select **BASE SENSOR TEST** from the DIAGNOSTICS menu.  
The following sensors are listed:
  - Toner Level—Toner level sensor (remove the cartridge and replace to actuate the sensor)
  - Input—Input sensor
  - Output—Output (exit) sensor
  - NarrowMedia—Output (exit) sensor
  - Front Door—Front door sensor
2. Manually actuate the sensors to verify that each sensor switches from **Open** to **Closed**.
3. Press **Stop**  to exit the test.

## DEVICE TESTS

### Quick Disk Test

This test performs a non-destructive read/write on one block per track on the disk. The test reads one block on each track, saves the data, and proceeds to write and read four test patterns to the bytes in the block. If the block is good, the saved data is written back to the disk.

To run the Quick Disk Test:

1. Touch  to select **Quick Disk Test** from DEVICE TESTS.  
The power indicator blinks while the test is in progress, and quick **Disk Test Testing...** displays.
  - **Quick Disk Test/Test Passed** message displays if the test passes, and the power indicator turns on solid.
  - **Quick Disk Test/Test Failed** message displays if the test failed, and the power indicator turns on solid.
2. Press **Stop**  to return to the Device Tests menu.

### Disk Test/Clean

**Warning:** This test destroys all data on the disk and should not be attempted on a good disk. Also note that this test may run approximately 1½ hours depending on the disk size.

To run the Disk Test/Clean Test:

1. Touch  to select **Disk Test/Clean** from the Device Tests menu.  
**Contents will be lost. Continue?** message displays to warn the user that all contents on the disk will be lost.
2. Touch **Yes** to continue and **No** to exit.  
If **Yes** is selected, the following screen displays and updates periodically, indicating the percentage of test completed.

```

Formatting Disk
1/1           0%
┌───────────┐
DO NOT POWER OFF
  
```

The power indicator blinks during the test.

**Note:** The test can NOT be canceled.

3. Once the test is complete, the power indicator turns on solid, and either the message **Disk Test/Clean Test Passed** or **Disk Test/Clean Failed** appears. If the message indicates failure, the disk is unusable.

## PRINTER SETUP

PRINTER SETUP		
Defaults	◀ US ▶ ▲	
Printed Page Count	127	
Permanent Page Count	127	
Serial Number	xxxxxxx 	
Engine Setting 1	◀ 0 ▶	
Engine Setting 2	◀ 0 ▶ ▼	
<input type="button" value="Submit"/> <input type="button" value="Back"/> <input type="button" value=""/>		

The triangles pointing up or down indicate whether there are additional menus. Touch the up or down arrows to display these additional menus.

**Note:** If you make changes, touch **Submit** to make the change effective.

### Defaults

US/Non-US defaults changes whether the printer uses the US factory defaults or the non-US factory defaults. The settings affected include paper size, envelope size, PCL symbol set, code pages, and units of measure.

**Warning:** Changing this setting resets the printer to factory defaults, and data may be lost. It cannot be undone.

### Printed Page Count

The page count can only be viewed and cannot be changed.

Touch **Back** to return to Diagnostics Menu.

### Permanent Page Count

The permanent page count can only be viewed and cannot be changed.

Touch **Back** to return to Diagnostics Menu.

### Serial Number

The serial number can only be viewed and cannot be changed.

Touch **Back** to return to Diagnostics Menu.

### Engine Settings 1 through 16

**Warning:** Do not change these settings unless requested to do so by your next level of support.

### Model Name

The model name can only be viewed and cannot be changed.



## Configuration ID

The two configuration IDs are used to communicate information about certain areas of the printer that cannot be determined using hardware sensors. The configuration IDs are originally set at the factory when the printer is manufactured, however, the servicer may need to reset Configuration ID 1 or Configuration ID 2 whenever you replace the system board. The IDs consist of eight hexadecimal characters, including 0 through 9 and A through F.

**Note:** When the printer detects a Configuration ID that is not defined or invalid, the following occurs:

- The default standard model Configuration ID is used instead.
- Configuration ID is the only function available in DIAGNOSTICS.
- Unless the menu is in DIAGNOSTICS, **Check Config ID** displays.

To set the configuration ID:

1. Touch  to select **PRINTER SETUP** from the Diagnostics Menu.
2. Touch  to select **Configuration ID**.
3. Touch the keyboard icon to display a keyboard with 1 through 0 and a through f. The current values for Configuration ID 1 and Configuration ID 2 are displayed.
  - Use keys to type the numbers for the two configuration IDs.
  - Use the left arrow to move over a digit from the right of the number toward the left.
  - When the numbers are correct, touch **Submit**.
  - If you have a question, touch the question mark icon.
  - To exit without changing the numbers, touch **Back**.

**Note:** Be sure to touch **Submit**, or the number will not be changed.

**submitting selection** displays, followed by the value for Configuration ID 1.

**Note:** If **Invalid ID** appears, the entry is discarded, and the previous Configuration ID 1 is displayed on the screen.

If the process is successful, **submitting selection** appears on the display, followed by the current value for Configuration ID 2.

4. Restart the printer.

## Edge to Edge

When this setting is On, the text and graphics are shifted to the physical edges of the paper for all margins. When the setting is Off, the normal margins are restored.

## EP SETUP

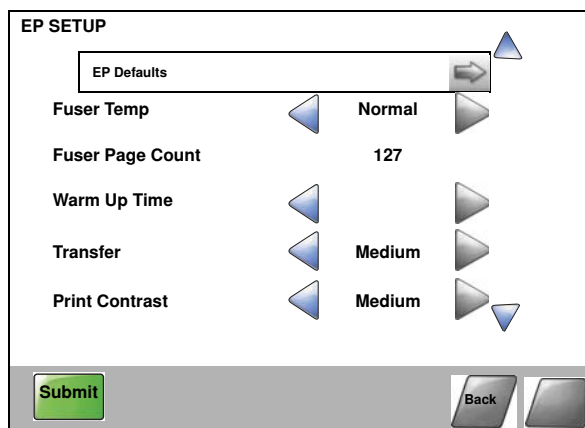



The triangles pointing up or down indicate whether there are additional menus. Touch the up or down arrows to display these additional menus.

**Note:** If you make changes, touch **Submit** to make the change effective.

## EP Defaults

This setting is used to restore each printer setting listed in EP SETUP to its factory default value. Sometimes this is used to help correct print quality problems.

To restore EP Defaults:

1. Touch  to select **EP Defaults** from EP SETUP.
2. Touch  to select **Restore** to reset the values to the factory settings, and touch  to select **Do Not Restore** to exit without changing the settings.

Touch **Back** to exit without changing the settings.

## Fuser Temperature (Fuser Temp)

This adjustment can be used to help solve some customer problems with paper curl on low-grade papers and problems with letterheads on some types of media.

The fuser temperature can be adjusted to: Normal, Lower, Lowest. The default is Normal.

Touch **Back** to return to Diagnostics Menu.

## Fuser Page Count

The fuser page count can only be viewed and cannot be changed.

Touch **Back** to return to Diagnostics Menu.

## Warm Up Time

You can change the amount of time the printer warms up before allowing pages to print by changing this setting from 0 to 5. The factory sets the warm up at 0 or no warm up time. This time period lets the backup roll heat up and helps reduce curl in some environments.

Touch **Back** to return to Diagnostics Menu.

## Transfer

The transfer can be adjusted to Low, Medium, or High. The default setting is Medium.

Touch **Back** to return to Diagnostics Menu.

## Print Contrast

The print contrast setting controls the developer voltage offset.

The print contrast can be adjusted to Low, Medium, or High. The default setting is Medium.

Touch **Back** to return to Diagnostics Menu.

## Charge Roll

The charge roll can be adjusted to Low, Medium, or High. The default setting is Medium.

Touch **Back** to return to Diagnostics Menu.

### Gap Adjust

The setting adjusts the minimum gap between sheets. Increasing this value may reduce curl of some printed media and eliminate some output bin stacking problems. However, increasing this value also results in slower overall performance, measured in pages per minute. The range of values is 0 to 255, and the default value is 0.

Touch **Back** to return to Diagnostics Menu.

### Auto Dark Adjust

The settings are Enable and Disable.

## REPORTS

### Menu Settings Page



This enables you to print the Menu Settings Page. The report prints the Diag Menu to include Registration, Print Tests, Hardware Tests, Duplex Tests, Input Tray Tests, Output Bin Tests, Device Tests, Printer Setup, EP Setup, Reports, Event Log, Development Menu, and Scanner Tests.

## EVENT LOG

### Display Log

The event log provides a history of printer errors. It contains the 12 most recent errors that have occurred on the printer. The most recent error displays in position 1, and the oldest error displays in position 12 (if 12 errors have occurred). If an error occurs after the log is full, the oldest error is discarded. Identical errors in consecutive positions in the log are entered, so there may be repetitions. All 2xx and 9xx error messages are stored in the event log.

To view the event log:

1. Touch  to select **Display Log** from EVENT LOG.  
Up to three error codes display at a time. Touch  to display additional information, if available.
2. Touch **Back** to return to the EVENT LOG menu.

## Print Log

Additional diagnostic information is available when you print the event log from Diagnostics Menu rather than Configuration Menu.

The Event Log printed from Diagnostics Menu includes:

- Detailed printer information, including code versions
- Time and date stamps
- Page counts for most errors
- Additional debug information in some cases

Model and Serial number

Printer information

Panel display when error occurred

Page count

Earliest error code

Next error code

```

Event Log (Page 1)
Lexmark X644a (sn:xxxxxxxx)

Device Information
Page Count          12
Installed Memory    256 MB
Processor Speed     514MHz
Engine ID           L1-M-0000-0
Engine              L1D-ML-P0A0-0
Lander             L1D-ML-P0A0-0
Base               L1D-ML-P0A0-0
A/D                L1D-ML-P0A0-0
Fax               L1D-ML-P0A0-0
Network            M12-M14-M0A0-0
Network Driver     L1D-ML-P0A0-0
Panel              v1.1.1
Firmware           8.11001-04.4
Scanner           0003 0033

Event Log Information

JFFS2 Partition Format
Panel Message      JFFS2 partition format: Security Files, 262144 Bytes
Page Count        2
Date and Time     Sun Sep 13 18:25:13 2009 UTC
Up Time          5 days 23 hrs 30 mins 16 secs 39k mem

Code Levels
1: Copyright L1D-ML-P0A0          Wed Sep 7 08:59:08 2009 min:big
2: Loader L1D-ML-P0A0           Wed Sep 7 10:01:00 2009 min:big
3: Kernel EE_APR_A02Ra          Wed Sep 7 10:00:36 2009 min:big
4: Base L1D-ML-P0A0             Wed Sep 7 10:01:37 2009 min:big
5: Network M12-M14-M0A0         Wed Sep 7 09:51:05 2009 min:big
6: A/D L1D-ML-P0A0              Wed Sep 7 10:01:17 2009 min:big
7: Network F11-F14n-1.0         Wed Sep 7 09:51:19 2009 min:big
8: L1D-ML-P0A0                  Wed Sep 7 10:01:35 2009 min:big
9: L1D-ML-P0A0                  Wed Sep 7 10:00:12 2009 min:big
10: Fax L1D-ML-P0A0             Wed Sep 7 10:00:13 2009 min:big
11: Network L1D-ML-P0A0         Wed Sep 7 10:01:05 2009 min:big
12: IP Stack 1.0                Wed Sep 7 10:01:05 2009 min:big
13: L1D-ML-P0A0                 Wed Sep 7 10:01:05 2009 min:big
14: Network M12-M14-M0A0       Wed Sep 7 10:01:05 2009 min:big
15: Bus/MemMgrData 1.0          Wed Sep 7 10:01:05 2009 min:big
16: M12-M14-M0A0                Wed Sep 7 10:01:05 2009 min:big
17: Fan Data 1.0                Wed Sep 7 10:01:05 2009 min:big
18: Engine L1-M-0000            Wed Sep 17 09:48:44 2009 min:big
19: M12-M14-M0A0                Wed Sep 7 10:01:05 2009 min:big
20: Network M11.0               Wed Sep 7 09:51:17 2009 min:big
21: Scanner 0003 0033

Scanner Jam
Panel Message      200.01 Scanner jam, remove all originals
Page Count        2
Date and Time     Tue Sep 15 18:24:40 2009 UTC
Up Time          5 days 23 hrs 29 mins 13 secs 19k mem
    
```

The printed event log can be faxed to Lexmark or your next level of support for verification or diagnosis.

To print the event log:

Touch to select **Print Log** from EVENT LOG.

## Clear Log

Use Clear Log to remove the current information in the Event Log. This affects both the viewed log and the printed log information.

1. Touch to select **Clear Log** from the Event Log menu.
2. Touch to select **Yes** to clear the Event Log, or touch to select **NO** to exit the Clear Log menu. If **YES** is selected, **Deleting EVENT LOG** displays on the screen.



## Configuration menu (CONFIG MENU) (model T656)

### Entering Configuration Menu (model T656)

1. Turn off the printer.
2. Press and hold **2** and **6** buttons simultaneously.
3. Turn on the printer.
4. Release the buttons after 10 seconds.

### Available menus

**Note:** Some menus are not available, depending on the configuration of the printer.

Maintenance Counter Value	See <b>“Maintenance Counter Value”</b> on page 3-49
Reset Maintenance Counter	See <b>“Reset Maintenance Counter”</b> on page 3-50
Print Quality Pages	See <b>“Print Quality Pages”</b> on page 3-51
Reports <ul style="list-style-type: none"> <li>• Menu Settings Page</li> <li>• Event Log</li> </ul>	See <b>“Reports”</b> on page 3-51
SIZE SENSING	See <b>“SIZE SENSING”</b> on page 3-52
Panel Menus	See <b>“Panel Menus”</b> on page 3-52
PPDS Emulation	See <b>“PPDS Emulation”</b> on page 3-52
Factory Defaults	See <b>“Factory Defaults”</b> on page 3-54
Energy Conserve	See <b>“Energy Conserve”</b> on page 3-54
Paper Prompts	See <b>“Paper Prompts”</b> on page 3-55
Envelope Prompts	See <b>“Envelope Prompts”</b> on page 3-55
Action for Prompts	See <b>“Action for Prompts”</b> on page 3-55
Jobs On Disk	See <b>“Jobs On Disk”</b> on page 3-55
Disk Encryption	See <b>“Disk Encryption”</b> on page 3-56
Wipe Disk	See <b>“Wipe Disk”</b> on page 3-57
Font Sharpening	See <b>“Font Sharpening”</b> on page 3-57
Require Standby	See <b>“Require Standby”</b> on page 3-57
LES Applications	See <b>“LES Applications”</b> on page 3-58
Key Repeat Initial Delay	See <b>“Key Repeat Initial Delay”</b> on page 3-58
Key Repeat Rate	See <b>“Key Repeat Rate”</b> on page 3-58
Wiper Message	See <b>“Wiper Message”</b> on page 3-58
Clear Custom Status	See <b>“Clear Custom Status”</b> on page 3-58

Touch **Exit Config Menu** to exit the Configuration Menu, and **Resetting the Printer** displays. The printer performs a POR, and the printer returns to the ready mode.

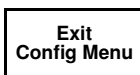

### Maintenance Counter Value

The current value for the maintenance page counter is displayed. This counter tracks printer usage. A print job containing a single page increments the counter by one and a duplex page by two. At 300,000, the customer is reminded that the printer requires scheduled maintenance. This counter is reset by the servicer after an 80 Scheduled Maintenance message displays and a maintenance kit is installed.

To view the maintenance page count, touch **⇒** to select **Maintenance Counter Value** from the Configuration Menu. The value is displayed and cannot be changed.

Touch **Back** to return to the main Configuration Menu.

### ***Reset Maintenance Counter***

After scheduled maintenance, the servicer needs to reset the page counter.

To reset the maintenance page count to zero:

1. Touch **⇒** to select Reset Maintenance Counter from the Configuration Menu.
2. Touch **Yes** to reset the counter, or touch **No** to exit without resetting the counter.

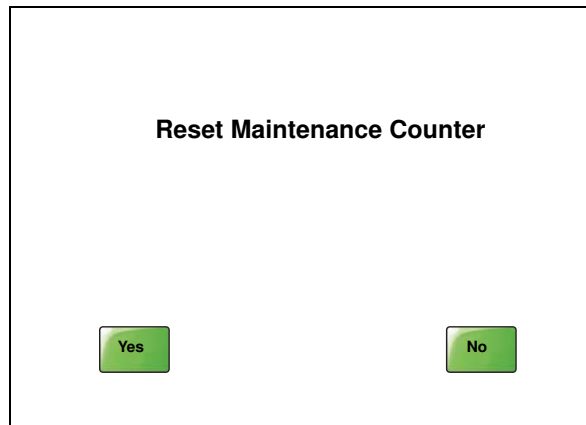

When the reset operation is complete, the menu returns to the main Configuration Menu.

## Print Quality Pages

The print quality test pages can be printed from either the Diagnostics Menu or Configuration Menu (CONFIG MENU). When printed from the Diagnostics Menu, additional information is included, and the print cartridge lockout is bypassed. See “**Print quality pages (Prt Quality Pgs)**” on page 3-26. Additional configuration information may be included on the print quality pages which is not included on the print menu page.

To print the Print Quality Test Pages, touch  $\Rightarrow$  to select **Print Quality Pages** from Configuration Menu. The message **Printing Quality Test Pages** is displayed.

The following is printed on the first page:

- Device Information to include page count, installed memory, processor speed, serial number, engine ID, system card ID, and printer revision levels
- Cartridge Information
- Printer Margin Settings
- Minimum Stroke Width

The print quality pages consist of four pages. Page one contains a mixture of graphics and text. Page two is gray with two one-inch black squares located on the bottom right. Page three is solid black page and page four is blank. If duplex is turned on, the pages are duplexed. The Print Quality Test pages are printed in English and must always be printed on letter, legal, or A4 paper.

## Reports

### Menu Settings Page

To print the Menu Settings Page, touch  $\Rightarrow$  to select **Menu Settings Page** from Reports. The message **Printing Menu Settings Page** is displayed.

The following settings are printed:

Maintenance Counter Value	USB Scan to Local	Print Quality Pages
Reports	SIZE SENSING	Panel Menu
PPDS Emulation	Factory Defaults	Energy Conserve
Min Copy Memory	NumPad Job Assist	Fax Storage Location
Disable Scanner	Paper Prompts	Envelope Prompts
Disk Encryption	Wipe Disk	ADF Edge Erase
Required Standby	LES Applications	Key Repeat Initial Delay
Key Repeat Rate	Wiper Message	Clear Custom Status
USB Speed		

Touch **Back** to return to the Configuration Menu.

### Event Log

The event log provides a history of printer errors. The event log can only be printed in CONFIG MENU. Additional options are available in DIAGNOSTICS. See “**EVENT LOG**” on page 3-23.

To print the event log:

1. Touch  $\Rightarrow$  to select **Event Log** from Configuration Menu.
2. Touch  $\Rightarrow$  to print the log. **Printing EVENT LOG..** displays on the touchscreen.

3. Touch **Back** to return to EVENT LOG.

**Note:** An event log printed from the CONFIG MENU will not contain debug information or secondary codes for 900 service errors. However, the event log printed from DIAGNOSTICS mode does include this information.

## SIZE SENSING

This setting controls whether the printer automatically registers the size of paper installed in an input source with size sensing.

Paper source	Size sensing
Tray 1 (integrated)	X
Multipurpose feeder	
250-sheet drawer	X
550-sheet drawer	X
2000-sheet drawer	X
250-sheet duplex	
550-sheet duplex	
Envelope feeder	

When the setting is Auto, every input option equipped with size sensing hardware automatically registers what size media it contains. When the setting is Off, the media size detected by hardware is ignored. The media size can be set by the operator panel or the data stream.

To change the size sensing setting:

1. Touch  $\Rightarrow$  to select **SIZE SENSING** from the Configuration Menu.
2. The panel displays the setting's name in the header and  $\blacktriangleleft$  [setting's current value]  $\blacktriangleright$  below the header row. Touch  $\blacktriangleleft$  or  $\blacktriangleright$  to change the setting. The selections are Auto and Off.
3. Touch **Submit** to save your change.

Touch **Back** to exit without changing the value.

## Panel Menus

To change the Panel Menus setting:

1. Touch  $\Rightarrow$  to select **Panel Menus** from the Configuration Menu.
2. The panel displays the setting's name in the header and  $\blacktriangleleft$  [setting's current value]  $\blacktriangleright$  below the header row. Touch  $\blacktriangleleft$  or  $\blacktriangleright$  to change the setting. The selections are On and Off. The default is Enable.
3. Touch **Submit** to save your change.

Touch **Back** to exit without changing the value.





## PPDS Emulation

This menu item allows the user to enable or disable PPDS emulation data stream. When this setting is enabled, the following settings are also changed:

- SmartSwitch settings for each port are turned off.
- The printer language is changed to PPDS Emulation.

Users can still switch languages on the operator panel and through the PJI data stream.

To change the PPDS Emulation setting:

1. Touch  to select **PPDS Emulation** from the Configuration Menu.
2. The panel displays the setting's name in the header and  *[setting's current value]*  below the header row. Touch  or  to change the setting. The selections are Deactivate and Activate. The default is Deactivate.
3. Touch **Submit** to save your change.

Touch **Back** to exit without changing the value.



## Factory Defaults

This setting enables a user to restore all the printer settings to the original factory settings. Selections are **Restore Base**, **Restore STD NET**, or **Restore LES**. Restore LES enables you to remove all Lexmark Embedded Solutions applications (LES).

Network does not appear unless you have a network printer. The following settings are not changed:

- Display language
- Settings in the NETWORK/PORTS MENU group.

To reset factory defaults:

1. Touch  to select Factory Defaults from the Configuration Menu.
2. Touch  to select either Restore Base, Restore STD NET, or Restore LES.



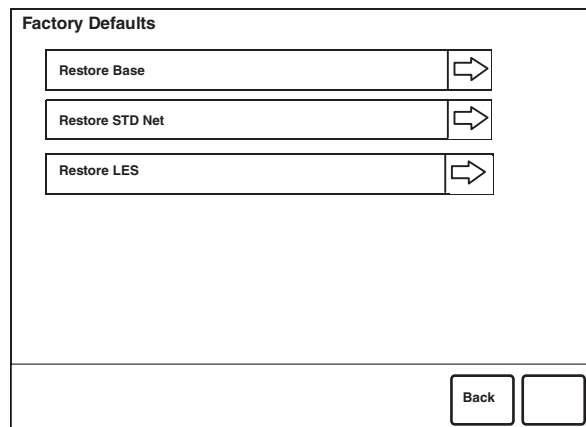

**Note:** There is no confirmation, and selecting one of these settings immediately takes effect. The printer restarts and returns to Ready state.

**Restoring Factory Defaults** and then **Resetting the Device** are displayed.



## Energy Conserve





This menu controls what values appear on the Power Saver menu. If **Off** is selected in Energy Conserve menu, then Disabled appears in the Power Saver menu, and Power Saver can be turned off. If **On** is set in Energy Conserve, the Power Saver feature cannot be disabled.

1. Touch  to select **Energy Conserve** from the Configuration Menu.
2. The panel displays the setting's name in the header and  [setting's current value]  below the header row. Touch  or  to change the setting. The selections are On and Off. The default is On.
3. Touch **Submit** to save your change.

Touch **Back** to exit without changing the value.

## Paper Prompts





When a tray is out of the indicated paper size, a prompt is sent to the user to load paper in a tray. This setting controls the tray the user is directed to fill.

1. Touch  to select **Paper Prompts** from the Configuration Menu.  
The panel displays the setting's name in the header and  [setting's current value]  below the header row.
2. Touch  or  to change the value.  
The values are Auto (default), Multi-Purpose Feeder, and Manual Paper.
3. Touch **Submit** to save the change.

Touch **Back** to exit without changing the value.





## Envelope Prompts

This setting controls the tray the user is directed to refill when a specific envelope size is out. The selections are **Auto** (default), **MP Feeder**, and **Manual Envelope**.

1. Touch  to select **Envelope Prompts** from the Configuration Menu.  
The panel displays the setting's name in the header and  [setting's current value]  below the header row.
2. Touch  or  to change the value.  
The values are Auto (default), MP Feeder, and Manual Envelope.
3. Touch **Submit** to save the change.

Touch **Back** to exit without changing the value.

## Action for Prompts



1. Touch  to select **Action for Prompts** from the Configuration Menu.  
The panel displays the setting's name in the header and  [setting's current value]  below the header row.
2. Touch  or  to change the value.  
The values are Prompt user (default), Continue, and Use current.
3. Touch **Submit** to save the change.

Touch **Back** to exit without changing the value.

## Jobs On Disk

If the hard disk is installed, Jobs On Disk allows the user to delete buffered jobs saved on the disk. The values are **Delete** and **Do Not Delete**.

To delete jobs saved on the disk:

1. Touch  to select Jobs On Disk from the Configuration Menu.
2. Touch  to select **Delete** to delete buffered jobs saved on the disk.
3. Touch  to select **Do Not Delete** cancel and return to the Configuration Menu.

## Disk Encryption

If a hard disk is installed, Disk Encryption selects whether the data on the disk is encrypted or not. The values are **Disable** and **Enable**. This setting determines if the printer encrypts the information that it writes to the hard disk.

**Warning:** If the value is changed from Enable to Disable or from Disable to Enable, then the printer completely formats the hard disk. All information on the disk will be unrecoverable.

To change this setting:

1. Touch  $\Rightarrow$  to select **Disk Encryption** from the Configuration Menu.  
**Note:** If an advanced password has been established, you must enter this password in order to change the setting. If no advanced password exists, you can establish one by using the keyboard that appears on the LCD.
2. Touch  $\Rightarrow$  next to either **Enable** or **Disable**.  
 If you remove an encrypted disk from a device and then try to install another disk, **Disk Corrupted. Reformat?** appears on the LCD. You can format the newly installed disk or remove it from the device.
3. **Contents will be lost. Continue?** appears on the touchscreen. Touch **No** to cancel or **Yes** to proceed. If you select Yes, the printer performs the selected action on the hard disk. The following graphic appears when the encryption process is selected:

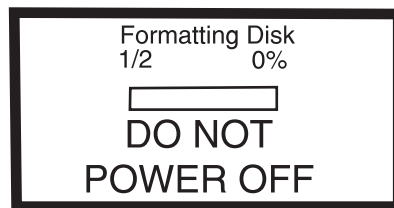

The panel provides many progress indicators during the two-stage process.

- 1/2 indicates that the process is currently in the first stage.
- 0% indicates the progress of the current stage of the process.
- The progress bar indicates the overall completion of the entire process by filling in throughout each separate stage.

When the first stage of either process completes, the printer displays either of the following graphics depending on the process selected and then begins the second stage of the process:

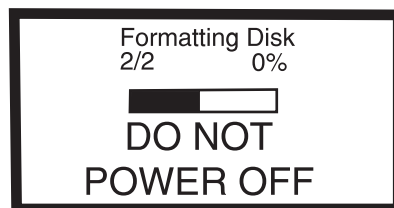

The entire process is complete when the progress bar appears completely shaded and the percentage indicator shows 100%. After completion, the panel returns to Disk Encryption.



## Wipe Disk

This setting provides you with a tool for erasing the contents of a disk.

**Warning:** Wipe Disk removes a disk's data in such a way that it cannot be recovered.

To change this setting:

1. Touch  $\Rightarrow$  to select **Wipe Disk** from Configuration Menu.
 

**Note:** If an advanced password has been established, you must enter this password in order to change the setting. If no advanced password exists, you can establish one by using the keyboard that appears on the LCD.
2. Touch  $\Rightarrow$  to select **Wipe disk (fast) or Wipe disk (secure)**.  
**Contents will be lost. Continue?** appears on the touchscreen.
3. Touch **Back** to return to Configuration Menu.
4. Touch **Yes** to continue, or touch **No** to exit.

## Font Sharpening

This setting allows a user to set a text point size below which the high frequency screens are used when printing font data. For example, at the default 24, all text in font sizes 24 and less will use the high frequency screens. The values for this setting range from 0 to 150, and the default value is 24. This setting affects PostScript, PCL, and XL.

To change this setting:

1. Touch  $\Rightarrow$  to select **Font Sharpening** from the Configuration Menu.
2. Touch  $\blacktriangleright$  to increase the value or  $\blacktriangleleft$  to decrease the value.
3. Touch **Submit** to save the change.

Touch **Back** to cancel and return to the Configuration Menu.

This function is not supported when the device generates output at 600 dpi resolution.

## Require Standby

This setting determines if the Standby Mode is On or Off. The default is On.

If Standby Mode is On, the printer begins functioning in Standby Mode when it remains idle for an amount of time. The Standby Mode enables the printer:

- To consume less energy than when operating in normal mode but not as little as when operating in Power Saver
- To return to the Ready state more quickly than when operating in Power Saver

To change this setting:

1. Touch  $\Rightarrow$  to select **Require Standby** from the Configuration Menu.
2. Touch **Submit** to save the change.

Touch **Back** to cancel and return to the Configuration Menu.

## ***LES Applications***

This disables all installed Lexmark Embedded Solution applications. The default is Enable.

To change this setting:



1. Touch  to select **LES Applications** from the Configuration Menu.  
**Note:** If an advanced password has been established, you must enter this password in order to change the setting. If no advanced password exists, you can establish one by using the keyboard that appears on the LCD.
2. Touch **Submit** to save the change.

Touch **Back** to cancel and return to the Configuration Menu.

## ***Key Repeat Initial Delay***

When a key is touched repeatedly, this is the delay before the key begins repeating. The delay ranges from 0.25 seconds to 5 seconds. The default is 1 second. Values are given in increments of 0.25 seconds.

To change this setting:



1. Touch  to select **Key Repeat Initial Delay** from the Configuration Menu.
2. Touch  to increase the value or  to decrease the value.
3. Touch **Submit** to save the change.

Touch **Back** to cancel and return to the Configuration Menu.

## ***Key Repeat Rate***

This is the number of times per second that a repeating key will repeat. The range is 1–100, with a default of 15 times per second.



To change this setting:

1. Touch  to select **Key Repeat Initial Delay** from the Configuration Menu.
2. Touch  to increase the value or  to decrease the value.
3. Touch **Submit** to save the change.

Touch **Back** to cancel and return to the Configuration Menu.

## ***Wiper Message***

To change this setting:

1. Touch  to select **Wiper Message** from the Configuration Menu.
2. Touch  or  to change the value. The values are On (default) and Off.
3. Touch **Submit** to save the change.

Touch **Back** to cancel and return to the Configuration Menu.

## ***Clear Custom Status***



No values exist for this operation. Pressing  initiates this operation.

Touch  to select **Clear Custom Status** from the Configuration Menu.

**Note:** Executing this operation erases any strings that have been defined by the user for the default or alternate custom messages.

## ***USB speed***

To change this setting:

1. Touch  to select **USB speed** from the Configuration Menu.
2. Touch  or  to change the value. The values are Auto (default) and Full.
3. Touch **Submit** to save the change.

Touch **Back** to cancel and return to the Configuration Menu.

## ***Exit Configuration Menu (model T656)***

Touch **Exit Config Menu** to exit the Configuration Menu. The printer performs a POR, and the printer returns to the ready mode.



## Printer overview



**CAUTION:** Do not set up this product or make any electrical or cabling connections, such as the power cord or options and features, during a lightning storm.

### Basic model

The following illustration shows the basic printer model.

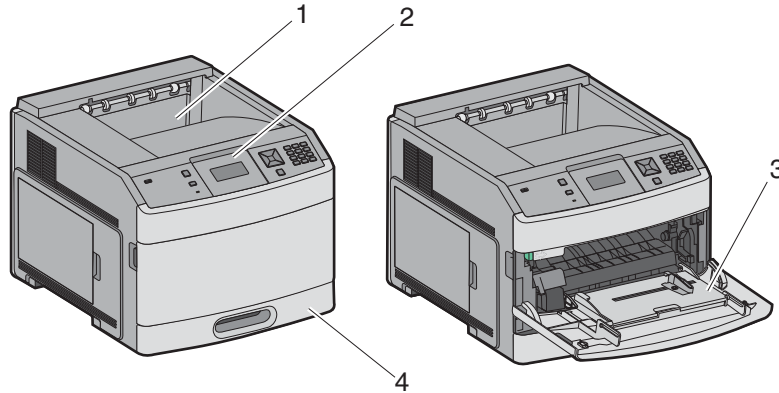

	Feature	Paper Capacity <sup>1</sup>
1	Standard exit bin	250- or 550-sheet
2	Printer control panel	NA
3	Multipurpose feeder	100 sheets
4	Standard tray (Tray 1)	250- or 550-sheets

<sup>1</sup>Based on 75 g/m<sup>2</sup> (20 lb.) paper.

# Printer theory

## Model T650 with duplex, paper path, rolls, and sensors

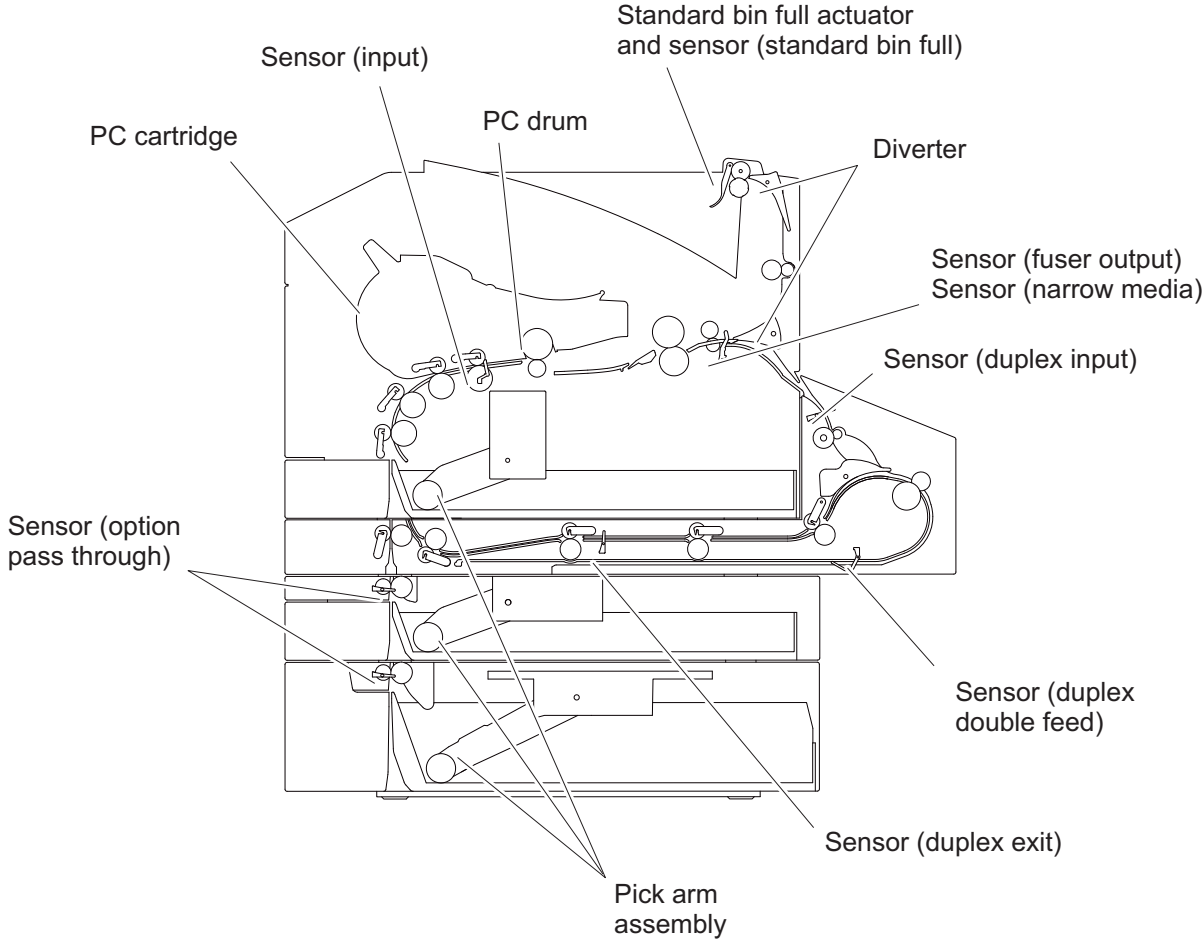

**Models T652 and T654 paper path rolls and sensors**

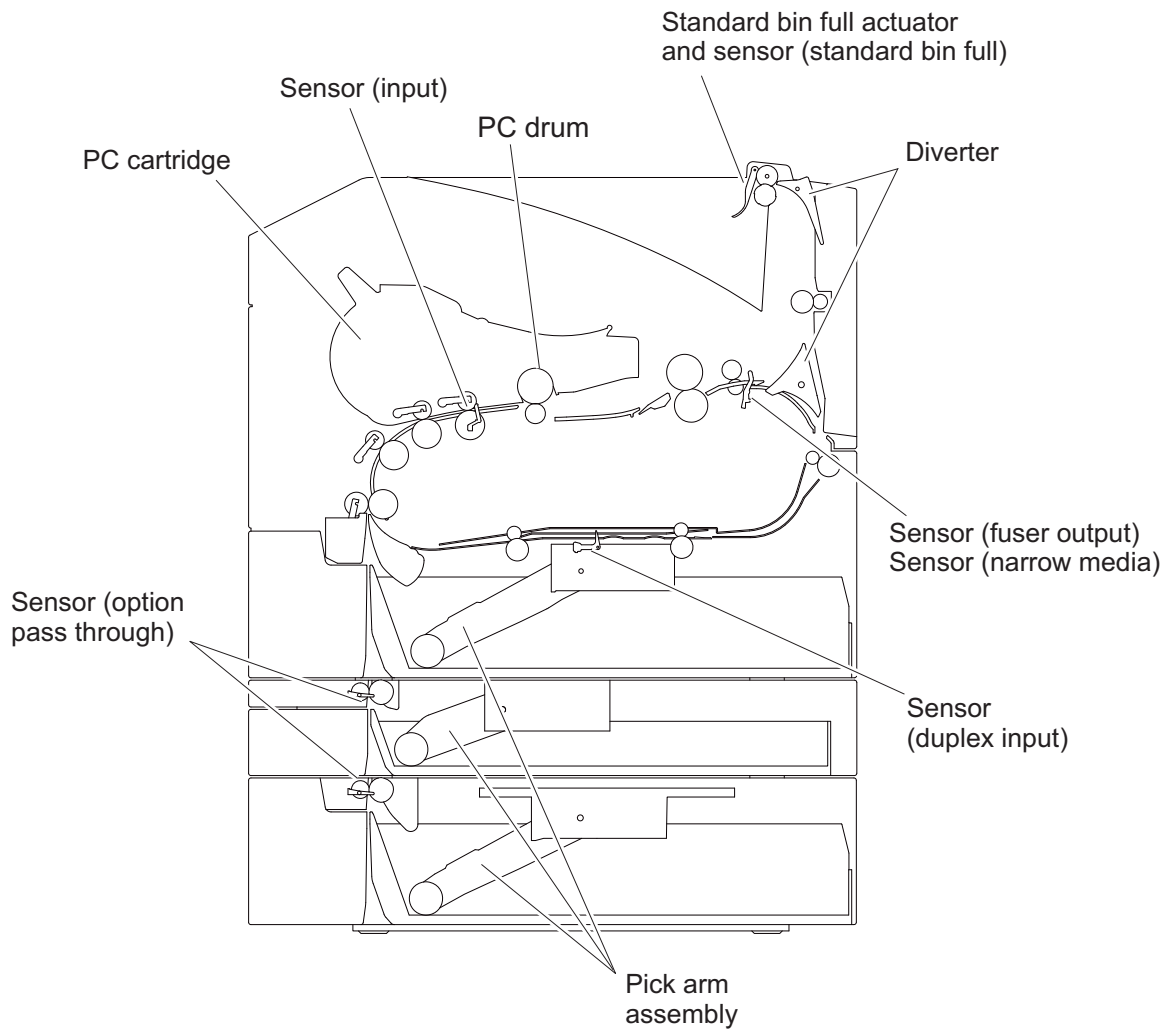

**Functions of main components**

- Media tray assembly
- Pic arm assembly (feed)
- MPF
- Xerographics
- Transfer
- Fuser
- Drive
- Electrical components and rolls

**Media tray assembly**

It is necessary to adjust the media tray rear guide and media tray side guide of the media tray assembly to match the media size.

**Rear media guide**

The rear media tray guide assembly can be adjusted to different media sizes by moving it to the front or rear. The rear guide should come into contact with the media and hold it in position.

### Side guide

The media tray assembly is designed so it can adapt to the media width in the media feed direction by moving the side guide to the left or right.

### Wear strips

The wear strips are designed to provide a fixed resistance to ensure that a single piece of paper is properly fed out of the media tray. There are several types of wear strips available for custom or hard to feed media.

## Media tray assembly

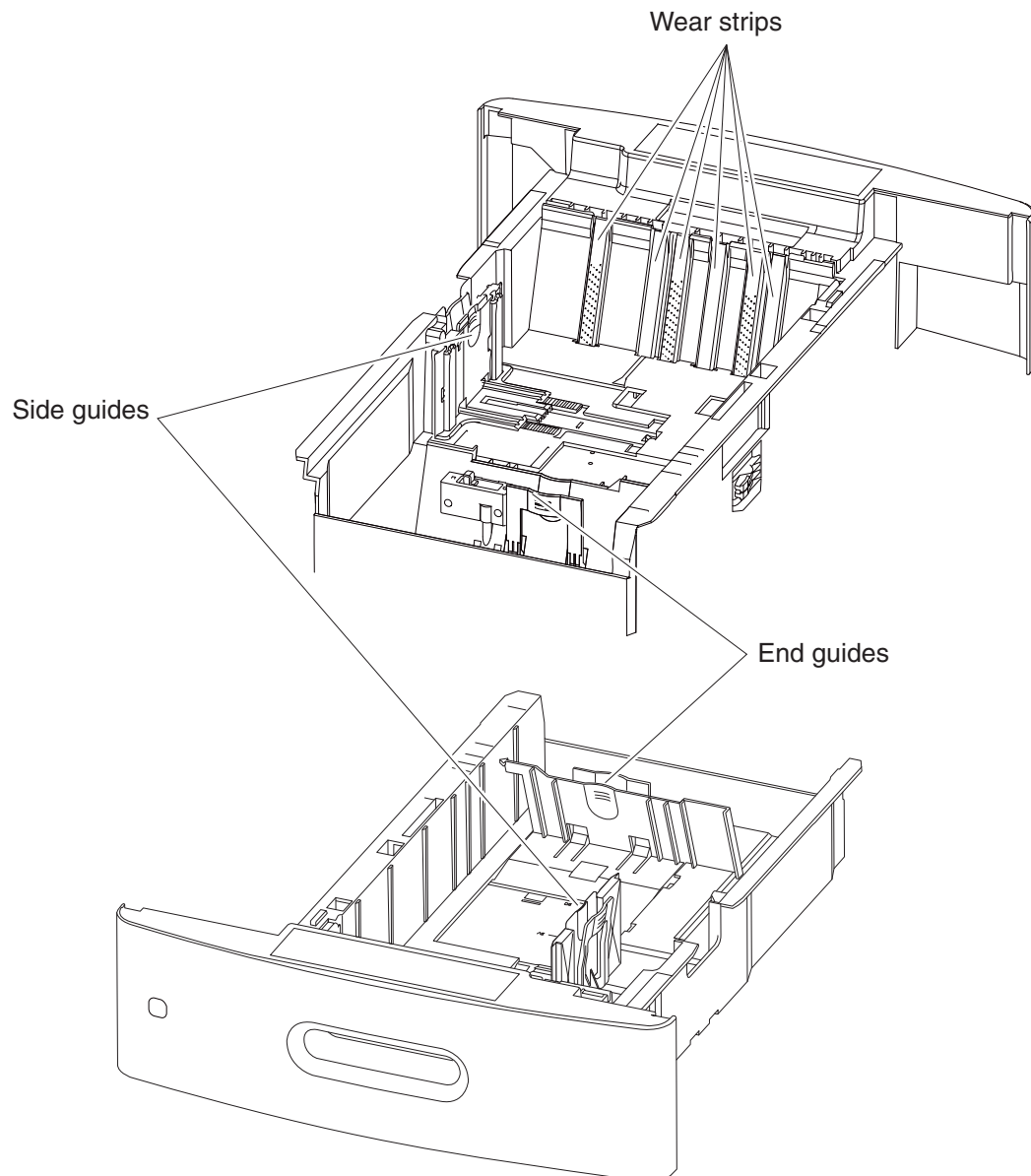

### Detection of media size

The media size set for the media tray assembly is transmitted to the switch (media size) by moving these guides. The media size is detected by the on/off information of these switches.

### Pick arm assembly

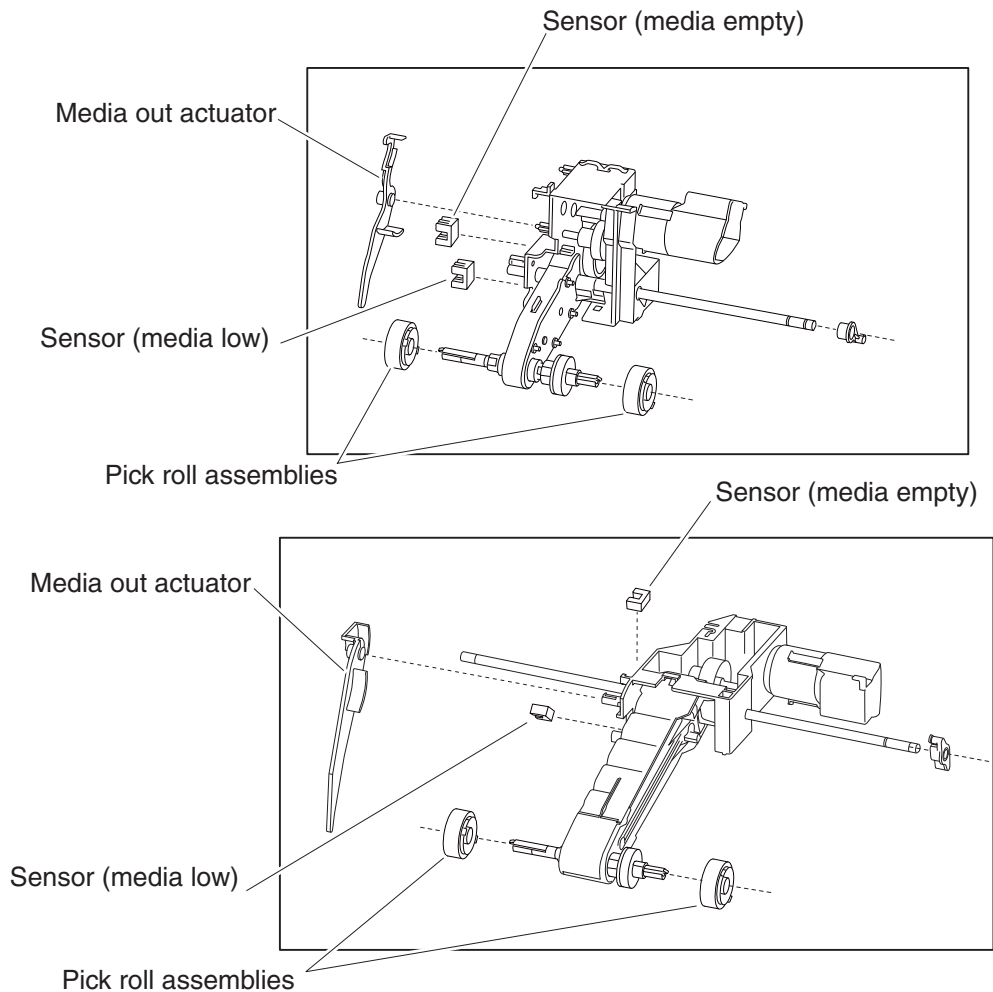

Since all media trays are functionally equivalent in terms of the switch (media size), sensor (media empty), sensor (media low), only the components of one tray are described here.

The pick arm assembly is a mechanical unit supplying media from the media tray assembly to the printer. The driving force, from the pick arm drive motor on the pick arm assembly, is transmitted to the two pick rolls to feed media.

When the pick rolls pick up media, the remaining media decreases, and the media out actuator will lower and interact with the sensor (media low) and sensor (media empty) to determine the amount of media remaining.

The pick arm assembly (autocompensator) is a paper pick device that generates its own normal force. This force generation is inherent in the fundamental design of the pick arm. If light media is used, it picks very gently. If a heavy media is used, it picks very aggressively. No customer adjustments are necessary, therefore no special trays are needed for card stock or labels. The gearing in the arm is designed so the input torque from the motor produces a movement about the pivot of the arm. This movement produces a downward force at the pick rolls. The friction between the pick roll and the paper produces a frictional locking condition. If the paper is physically held and not allowed to feed, then the motor stalls. Slippage between the roll and the paper is theoretically impossible. When the motor is energized, the pick rolls are driven down into the stack, increasing the normal force and drive force until the bending strength of the paper is overcome and the paper bends and moves up the wear strip.



### Switch (media size)

This switch (media size) sets the size of media supplied from each media tray assembly. A signal indicating the media size is transmitted as a voltage to the printer system card assembly.

### Sensor (media empty)

If media runs out in a media tray assembly, the actuator lowers and the actuator flag, unlocks the sensing area of the sensor (media empty). The sensor light is transmitted. When the sensing area is blocked (media is present), the signal is off.

### Sensor (media low)

This sensor detects by the actuator position whether media in the media tray assembly is low. When the flag of the actuator blocks, then unblocks the sensing area of the sensor (media low), the media level is determined to be low.

## Multi-purpose feeder (MPF)

The MPF is a mechanical unit supplying media to the printer. The driving force from the main drive motor drive motor is transmitted to the MPF pick roll to feed media.

MPF pick solenoid

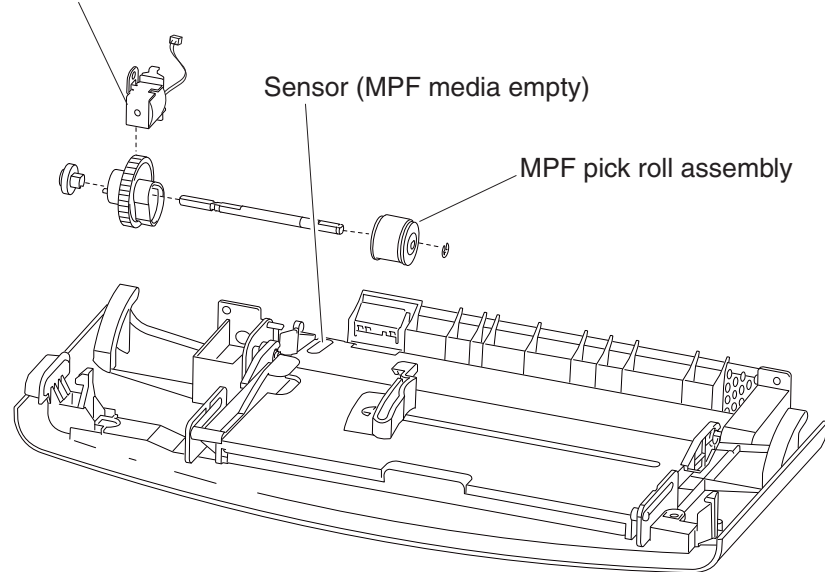

### MPF feed roll

The MPF pick roll feeds the media set on the MPF into the printer.

### MPF pick solenoid

The MPF pick solenoid transmits the driving force from the main drive motor assembly to the MPF pick roll.

### Sensor (MPF media empty)

The sensor (MPF media out) detects whether media is present on the MPF.

## Supported paper sizes, types, and weights

The following tables provide information on standard and optional paper sources and the types of paper they support.

**Note:** For an unlisted paper size, select the closest larger listed size

### Paper sizes supported by the printer

Paper size	Dimensions	250-or 550-sheet trays (standard or optional)	Optional 2000-sheet tray	Multipurpose feeder	Duplex unit
A4	210 x 297 mm (8.3 x 11.7 in.)	x	x	x	x
A5	148 x 210 mm (5.8 x 8.3 in.)	x		x	x
A6 <sup>1,2</sup>	105 x 148 mm (4.1 x 5.8 in.)			x	
J15 B5	182 x 257 mm (7.2 x 10.1 in.)	x		x	x
Letter	216 x 279 mm (8.5 x 11 in.)	x	x	x	x
Legal	216 x 356 mm (8.5 x 14 in.)	x	x	x	x
Executive	184 x 267 mm (7.3 x 10.5 in.)	x		x	x
Oficio <sup>1</sup>	216 x 340 mm (8.5 x 13.4 in.)	x		x	x
Folio <sup>1</sup>	216 x 330 mm (8.5 x 13 in.)	x		x	x
Statement <sup>1</sup>	140 x 216 mm (5.5 x 8.5 in.)	x		x	
Universal <sup>3,4</sup>	138 x 210 mm (5.5 x 8.3 in.) up to 216 x 356 mm (8.5 x 14 in.)	x		x	
	70 x 127 mm (2.8 x 5 in.) up to 216 x 356 mm (8.5 x 14 in.)			x	
	148 x 182 mm (5.8 x 7.7 in.) up to 216 x 356 mm (8.5 x 14 in.)	x		x	x
7 3/4 Envelopes (Monarch)	98 x 191 mm (3.9 x 7.5 in.)			x	
9 Envelope	98 x 225 mm (3.9 x 8.9 in.)			x	
10 Envelope	105 x 241 mm (4.1 x 9.5 in.)			x	
DL Envelope	110 x 220 mm (4.3 x 8.7 in.)			x	

Paper size	Dimensions	250-or 550-sheet trays (standard or optional)	Optional 2000-sheet tray	Multipurpose feeder	Duplex unit
Other Envelope	98 x 162 mm (3.9 x 6.4 in.) to 176 x 250 mm (6.9 x 9.8 in.)			x	
<p><sup>1</sup>This size appears in the Paper Size menu only when the paper source does not support size sensing or when size sensing is turned off.</p> <p><sup>2</sup>Only the standard exit bin supports this size.</p> <p><sup>3</sup>This size setting formats the page for 216 x 356 mm (8.5 x 14 in.) unless the size is specified by the software application.</p> <p><sup>4</sup>To support duplexing, the Universal width must be between 148 mm (5.8 in) and 216 mm (8.5 in); Universal length must be between 182 mm (7.2 in) and 356 mm (14 in).</p>					

## Registration

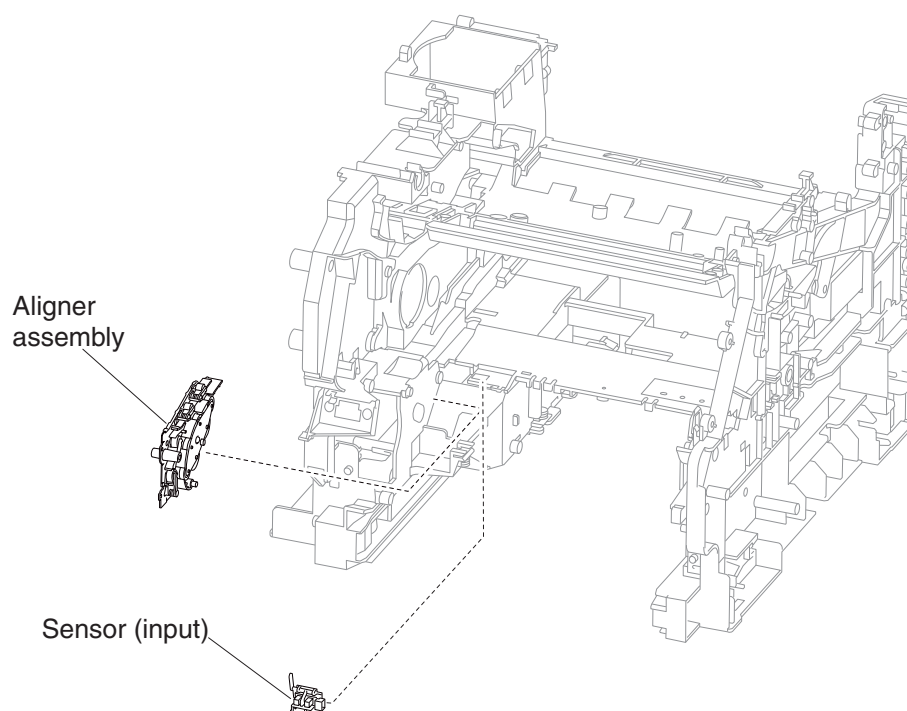

### Sensor (input)

The sensor (input) is located just before the print cartridge and can detect whether media exists in the input path.

### Aligner assembly

The aligner assembly is used to feed the media through the input path and to ensure that media is fed through the machine in a perfectly straight manner and not in a skewed manner. The aligner assembly can be adjusted to correct media skew issues and should always be adjusted when it is replaced.

## **Transfer**

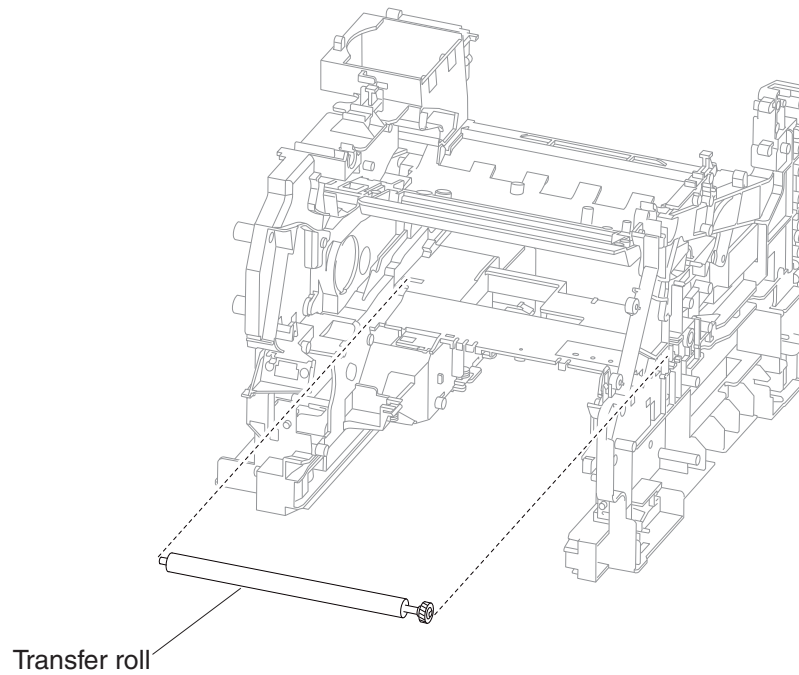

### **Transfer roll assembly**

The transfer roll assembly applies charge to the rear surface of the media when the media passes between the transfer roll assembly and photo conductor (drum). Thus, the toner image is transferred from the photo conductor (drum) surface to the media surface.

## Polygon printhead assembly

The printhead scans the photo conductor drum surface with a laser beam. It consists of four components: laser diode (LD) card assembly, printhead motor, polygon mirror, and the start of scan card assembly.

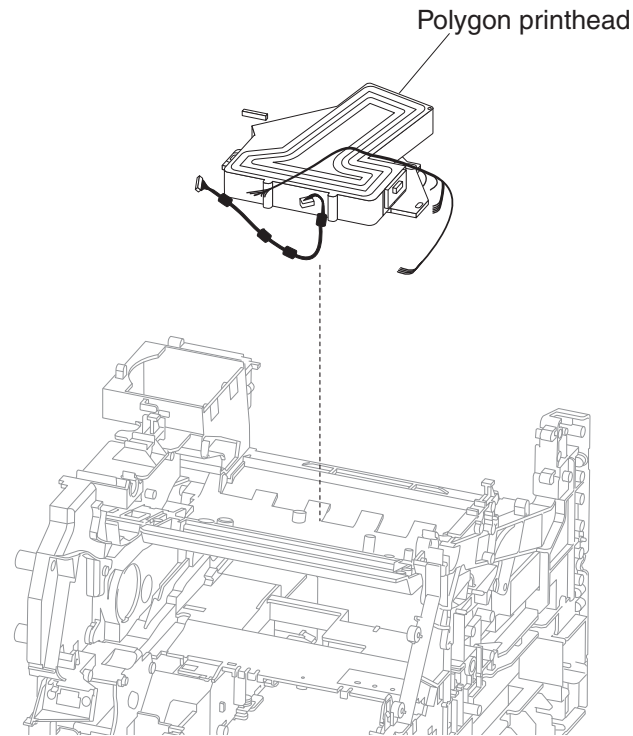

1. LD card assembly — generates the laser beam. The beam is turned on or off according to a print data signal coming from the system card.
2. Printhead motor/polygon mirror — the polygon mirror is mounted to the shaft of the printhead motor, and is rotated at a high speed by the printhead motor. The mirror rotation shifts the incidence and reflection angles of a laser beam to scan the photoconductor (drum) in a single direction. The laser beam reaches the polygon mirror as it passes through multiple lenses, mirrors, and windows. The laser beam then arrives at the photo conductor (drum) surface.
3. SOS card assembly — when a laser beam hits the SOS sensor on the SOS card assembly, the beam is converted to an electrical signal (SOS signal), and detects the initial position where a scan starts on each line.

When a laser beam is scanned across the photoconductor (drum) surface from one end to the other while turning on and off the beam, one line of latent image is created. If the scanning by the laser beam is repeated while rotating the drum, a two-dimensional image is created. The resolution in the scanning direction (from right to left) is determined by the rotational speed of the printhead motor, depending on how quickly the laser is adjusted. The resolution in the process direction (from top to bottom) is determined by the rotational speed of the printhead motor. (The higher the scanning speed becomes, the sooner the scanning of the next row can be started.)

Conceptual diagram of an image created by scanning

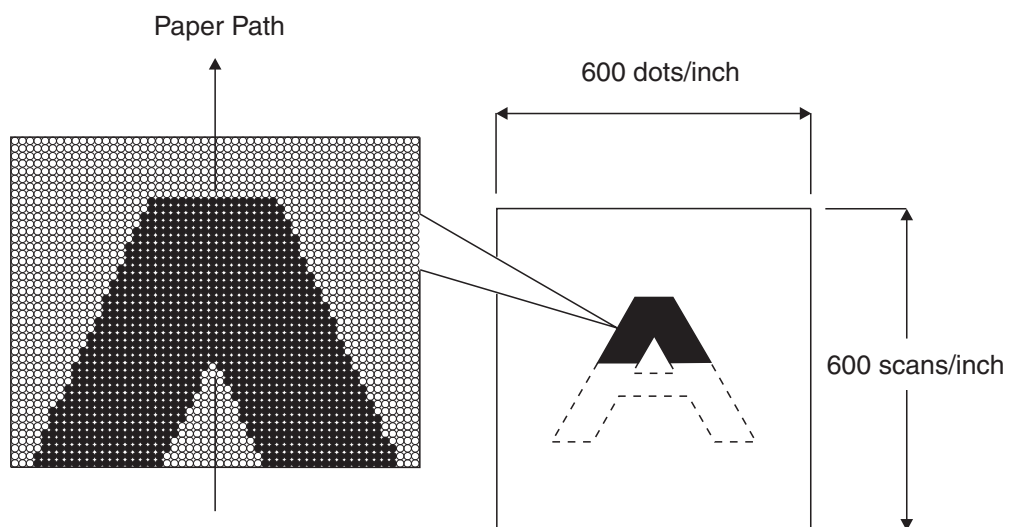

## Oscillating printhead assembly

The oscillating printhead scans the photo conductor drum surface with a laser beam. It consists of four components: laser diode (LD) card assembly, magnetic motor, mirror, and the start of scan card assembly.

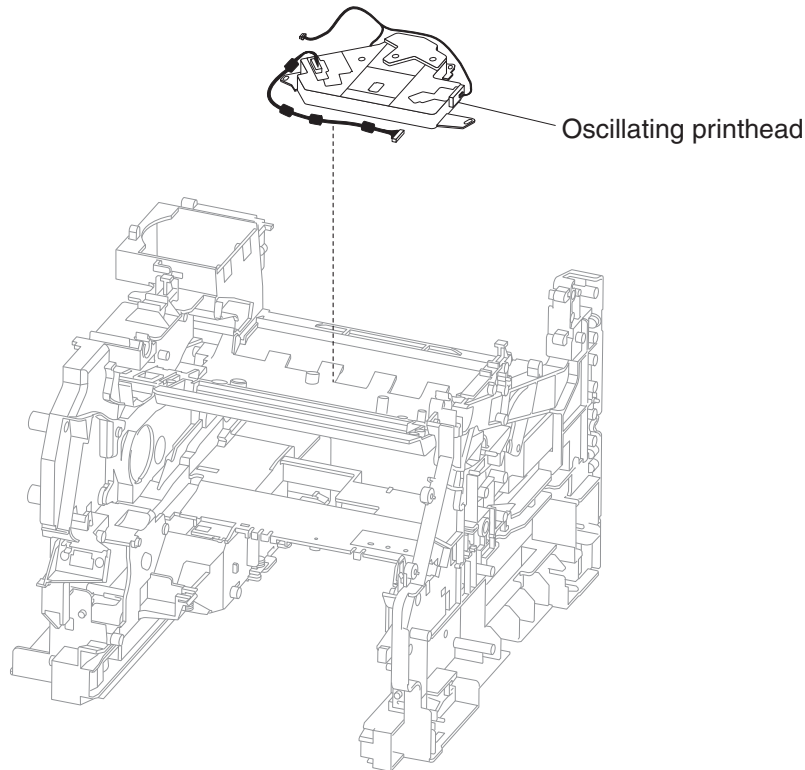

1. LD card assembly — generates the laser beam. The beam is turned on or off according to a print data signal coming from the system card.
2. Magnetic motor/ mirror — the mirror is mounted to the shaft of the magnetic motor, and is oscillated at a high speed by the magnetic motor. The mirror rotation shifts the incidence and reflection angles of a laser beam to scan the photo conductor (drum) axial in both directions. The laser beam reaches the mirror as it passes through multiple lenses, mirrors, and windows. The laser beam then arrives at the photo conductor (drum) surface.
3. SOS card assembly — when a laser beam hits the SOS sensor on the SOS card assembly, the beam is converted to an electrical signal (SOS signal), and detects the initial position where a scan starts on each line.

When a laser beam is scanned across the photoconductor (drum) surface from one end to the other while turning on and off the beam, one line of latent image is created. If the scanning by the laser beam is repeated while rotating the drum, a two-dimensional image is created. The resolution in the scanning direction (from right to left) is determined by the rotational speed of the printhead motor, depending on how quickly the laser is adjusted. The resolution in the process direction (from top to bottom) is determined by the rotational speed of the printhead motor. (The higher the scanning speed becomes, the sooner the scanning of the next row can be started.)

## Fuser

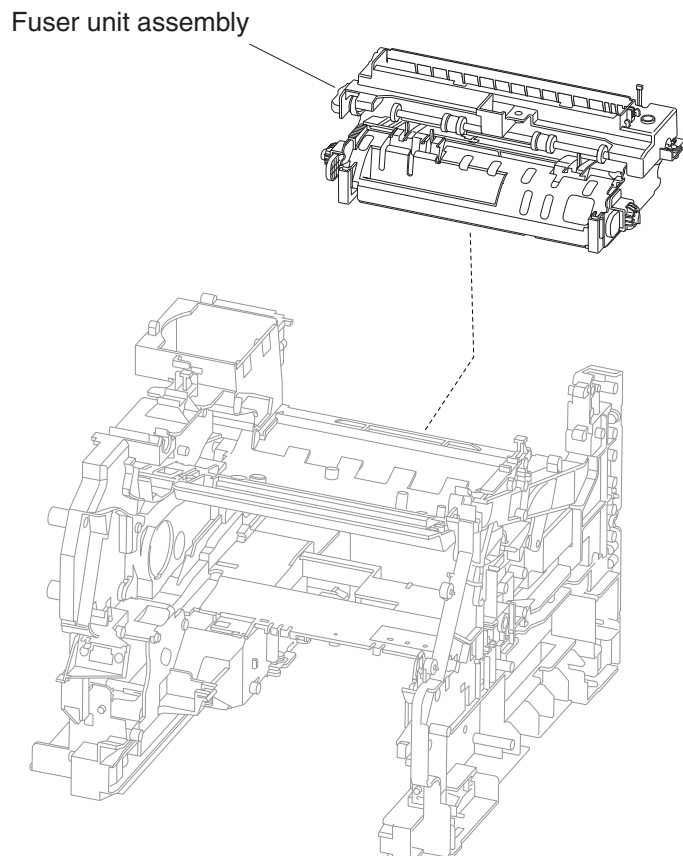

## Fuser components

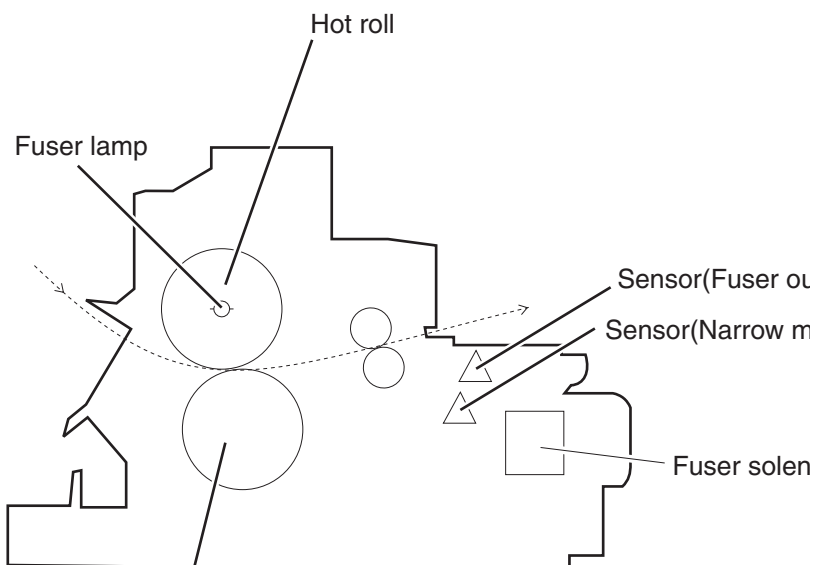



## Heat roll

The heat roll is a hollow metal tube with a coated surface. This tube is heated by the inner heater lamp. The heat is applied to the media passing between the heat roll and pressure roll, fusing the toner on the media.

## Pressure roll

The pressure roll is used to apply pressure to the media surface for fusing. Pressure is applied to the media between the pressure roll and heat roll, pressing the melted toner against the media.

## Heater lamp

The heater lamp is a quartz glass tube containing a heater coil. A terminal is mounted to the end of the heater rod via a harness.

## Thermal cutoff

If the heat roll temperature exceeds the preset temperature, the thermal cutoff cuts off the circuits of the main heater lamp and sub heater lamp.

## Thermistor

The thermistor monitors the surface temperature of the media-feed portion of the heat roll to control on/off of the main heater lamp and sub heater lamp.

## Sensor (fuser output)

The sensor (fuser output) detects the arrival of media at the detection point in the exit area of the fuser, and also detects the ejection of media from this point.

## Sensor (narrow media)

The sensor (narrow media) detects the arrival of narrow media at the detection point in the exit area of the fuser, and also detects the ejection of media from this point. It is used to make adjustments to ensure that narrow media is properly fused.

## ***Fuser unit assembly (type 1 and type 2)***

### **Type 1 fuser unit assembly**

In the type 1 fuser unit assembly, the detacs, which are used to prevent the media from sticking to the hot roll, do not make contact with the hot roller. The type 1 fuser unit assembly has a life of 300K.

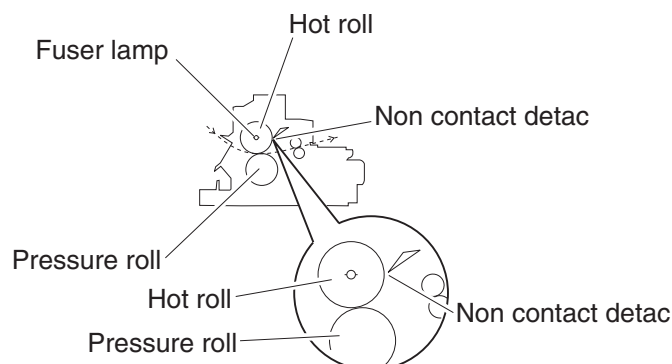

### Type 2 fuser unit assembly

In the type 2 fuser unit assembly, the detacs, which are used to prevent the media from sticking to the hot roll, do make full contact with the hot roller. The type 2 fuser unit assembly has a life of 150K.

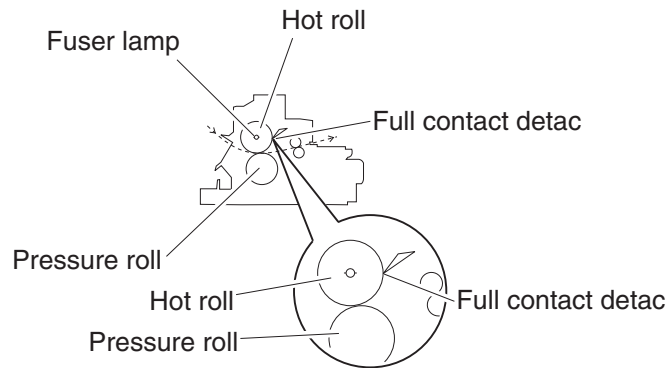

### Exit

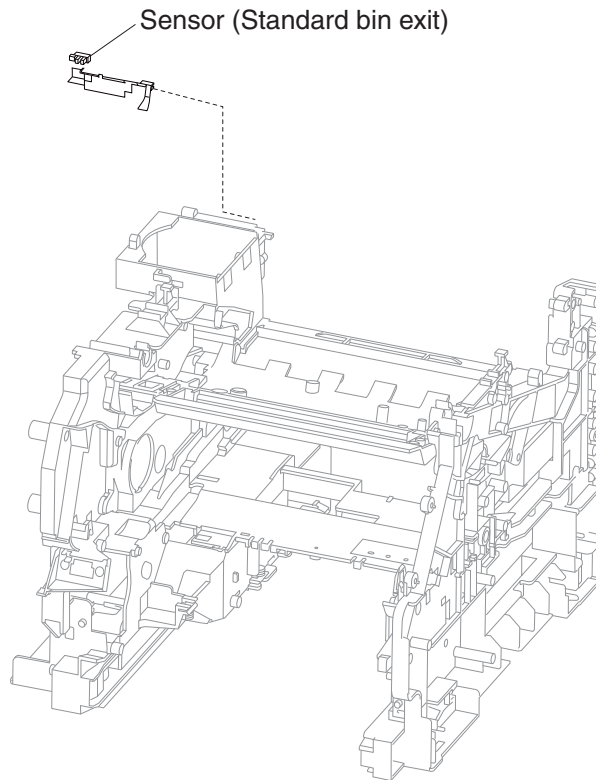

The standard media exit ejects printed media from the printer to the standard bin .

### Sensor (standard bin full)

The sensor (standard bin full) detects whether the standard bin is full by moving the actuator up and down.

## Drive

### Main drive motor assembly

The main drive motor is a DC motor that drives the print cartridge, aligner, MFP and fuser.

### Redrive motor assembly

The redrive motor assembly is a DC motor that drives the redrive assembly that transports the media into the standard bin or output option.

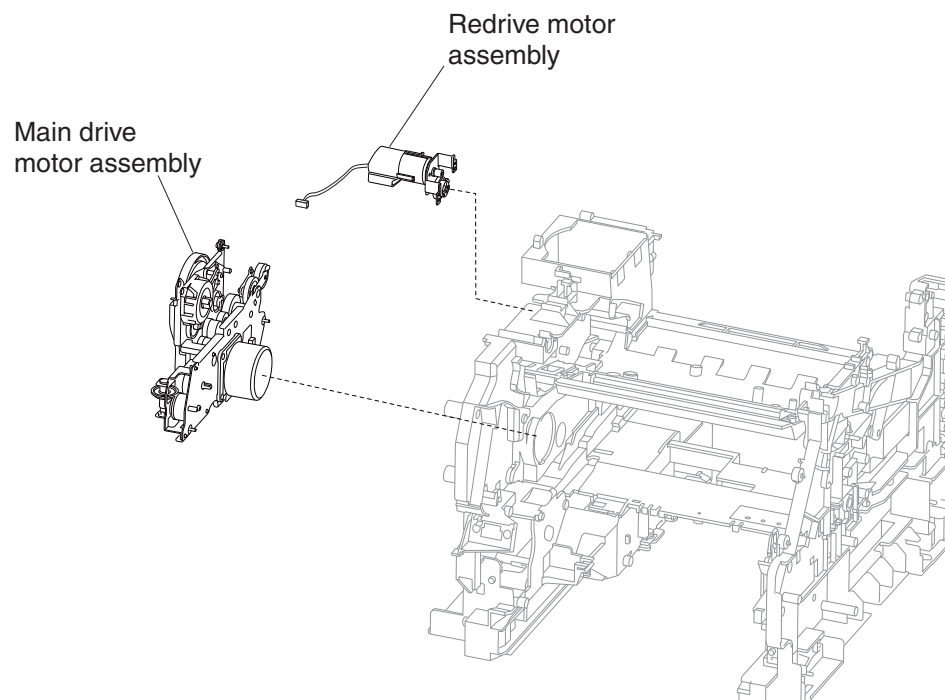

## Electrical components and controller

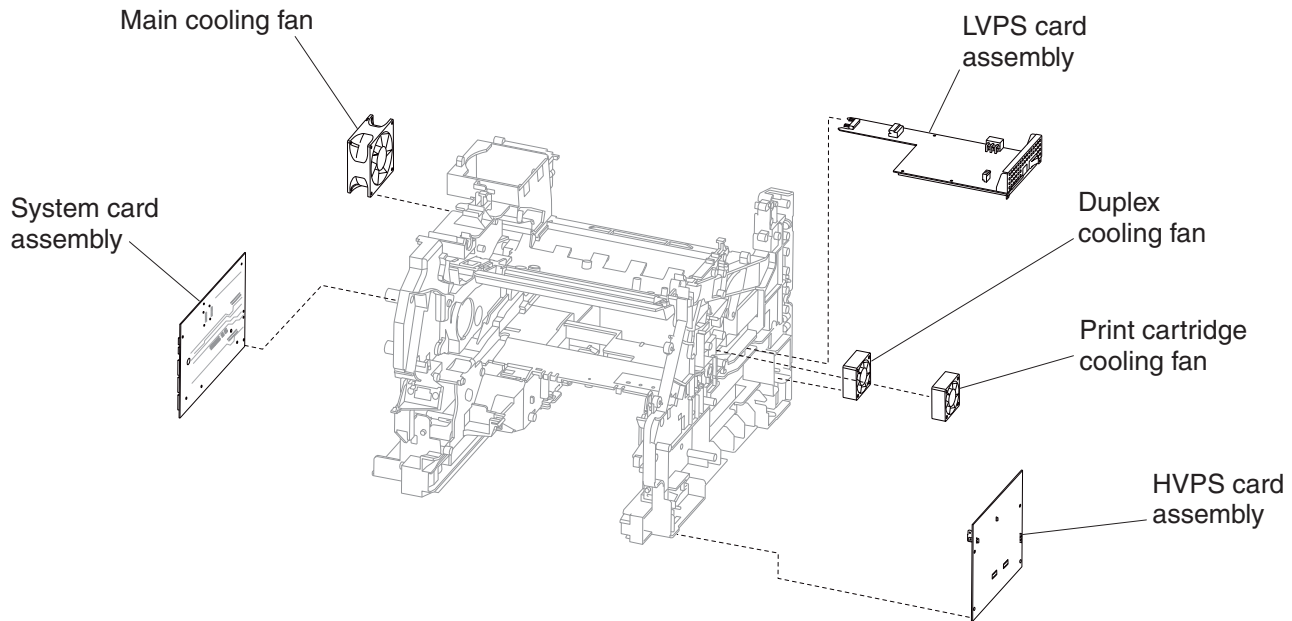

### Switch (printer front door interlock)

The switch is a safety switch to cut off a 24 VDC power supply from the LVPS card assembly to the high volt power supply (HVPS) card assembly, printer system card assembly and to the main drive motor assembly, while the printer front door assembly is open.

### Main cooling fan

The main cooling fan discharges air from the printer to prevent excessive temperature increase.

### Print cartridge cooling fan

The print cartridge cooling fan discharges air from the print cartridge area to prevent excessive temperature increase.

### Duplex cooling fan

The Duplex cooling fan discharges air from the duplex drive motor area to prevent excessive temperature increase.

### LVPS card assembly

The LVPS card assembly generates low voltages 5V for logic circuits, 5 V for laser diodes and 24V for cooling fans. The LVPS is switchable and can be switched to work with 100V, 110 and 220V machines.

### HVPS card assembly

The HVPS card assembly generates AC power and feeds it to the developer roll, the transfer roll assembly and the charge roll assembly.

## System card assembly

The system card assembly controls printing operation based on the communication with the RIP controller and optional peripherals. It also controls toner dispense, fuser control, sensor switch feedback, drive motors, clutches and solenoids

---

## Control

### *Printhead control*

#### Rotation of printhead motor

The on/off control of the printhead motor is performed according to the mode of operation as shown below.

Operation mode	PRINTHEAD motor on/off
Standby mode	Always off
Print mode	Turns on upon receiving the signal from the controller, and turns off after a preset time has passed from the end of printing. Also turns off if a print command is not received within 30 seconds from the reception of the signal.
Sleep mode	Always off

#### Determination of printhead ready

The printhead goes into ready state after the specified period passes since the reception of the printhead MPA start signal and the SOS cycle exceeds the reference value.

#### Printhead reference value

Printhead reference value	Description
Ready reference value	SOS signal interval (equivalent to 98% or more of the rated RPM of the printhead motor)
Fail reference value	SOS signal interval (less than 98% of the rated rpm of the printhead motor)

### *Fuser control*

#### Fuser control method

The on/off control of the main/sub heater lamps is performed based on the fuser control temperature. The fuser transmits between the five states (warm up, ready, standby, print, and low power) depending on the heat roll surface temperature or printer conditions.

The fuser temperature control starts when the fuser ready in the system card assembly is turned on after a preset time period has passed from power on. If a failure occurs, the heater lamps are turned off, the fuser ready is turned off, and then the fuser temperature control is stopped.

#### Fuser lamp on/off control

The thermistor detects the heat roll surface temperature (fuser temperature) to regulate the temperature at the target control temperature by turning on or off the heater lamp.

### Fuser warm-up

The fuser warm-up starts at the time of power on, interlock open or close, jam reset, or return from the low power mode, and ends when the ready temperature is attained, when a failure occurs, or when executing diagnosis.

### Xerographic and print cartridge components

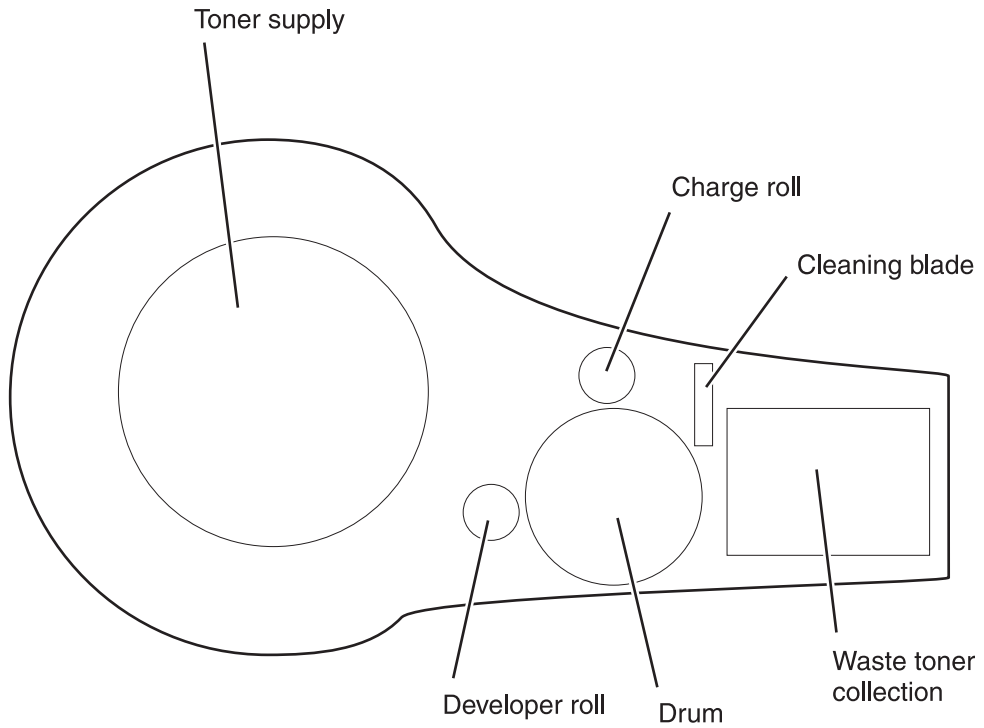

## Charge

The Charge Roll places a uniform negative electrostatic charge on the surface of the drum. The drum surface is made of a photoconductive material that holds an electrical charge as long as the drum remains in darkness. Light striking the drum discharges the surface charge.

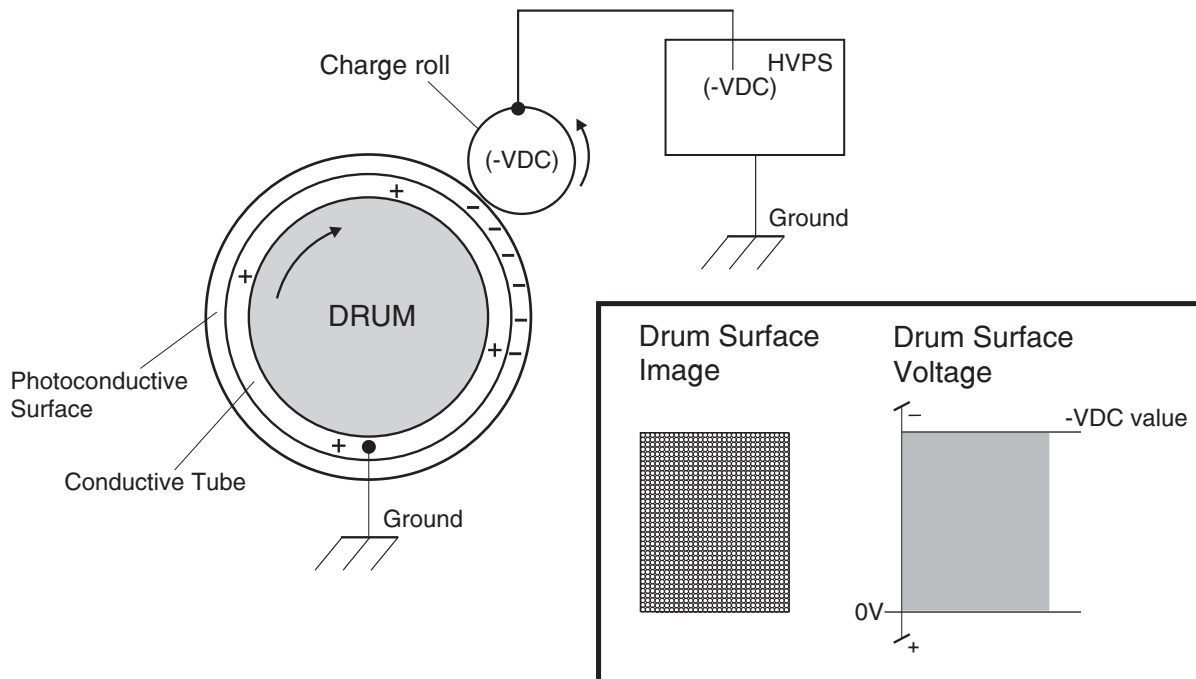

## Exposure

The Printhead generates a beam of laser light. Image data received from the system card assembly modulates this beam, turning it on and off according to image information that is received from the host computer and software.

Through the use of a series of rotating and stationary mirrors within the Printhead, the beam scans the negative charged drum surface. Whenever the print controller sends a command to print a black pixel, the laser switches on long enough to shine onto the drum at a single pixel point. That point is now discharged and slightly less negative than the surrounding negative charge. The less negative areas are considered positive.

This discharge/no discharge process creates an invisible, electrostatic image on the surface of the drum. This image is called a **latent** image.

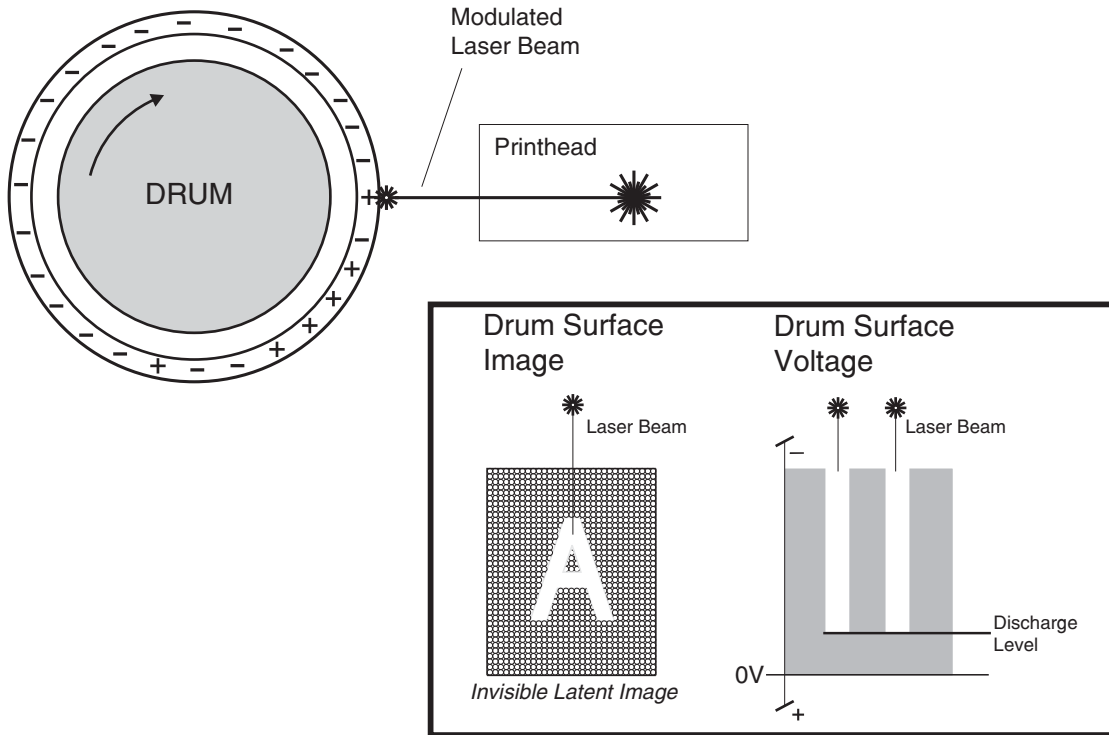

**Development**

The toner contained within the PC Cartridge has an electrical property that causes it to adhere to the development roll. The Metering Blade spreads the toner into a very thin layer on the development roll. Friction between the development roll and the CM Blade development roll generates a small electrical charge that is transferred to the toner.

The surface of the developer Roll is made up of a thin sheet of conductive material. The HVPS supplies the development Roll with two voltages: a DC voltage and an AC voltage. The DC voltage is used to transfer toner from the development roll to the surface of the drum. The AC voltage agitates the toner on the development roll, making toner transfer easier.

The development roll maintains a negative DC electrical potential. Negative charged areas of the drum have a lower electrical potential, or higher relative negative value than the development roll. Discharged areas of the drum have a higher electrical potential, or lower relative negative value, than the development roll. A discharged point on the surface of the drum now appears less negative in relation to the negative charge on the development roll.

The toner adhering to the development Roll is always in contact with the drum surface. When a less negative point on the drum (a discharged area) comes in contact with the more negative charged toner on the Magnet



Roll, toner transfers from the Magnet Roll to that point on the drum. There is now a visible toner image on the drum surface. The image is called a *developed* image.

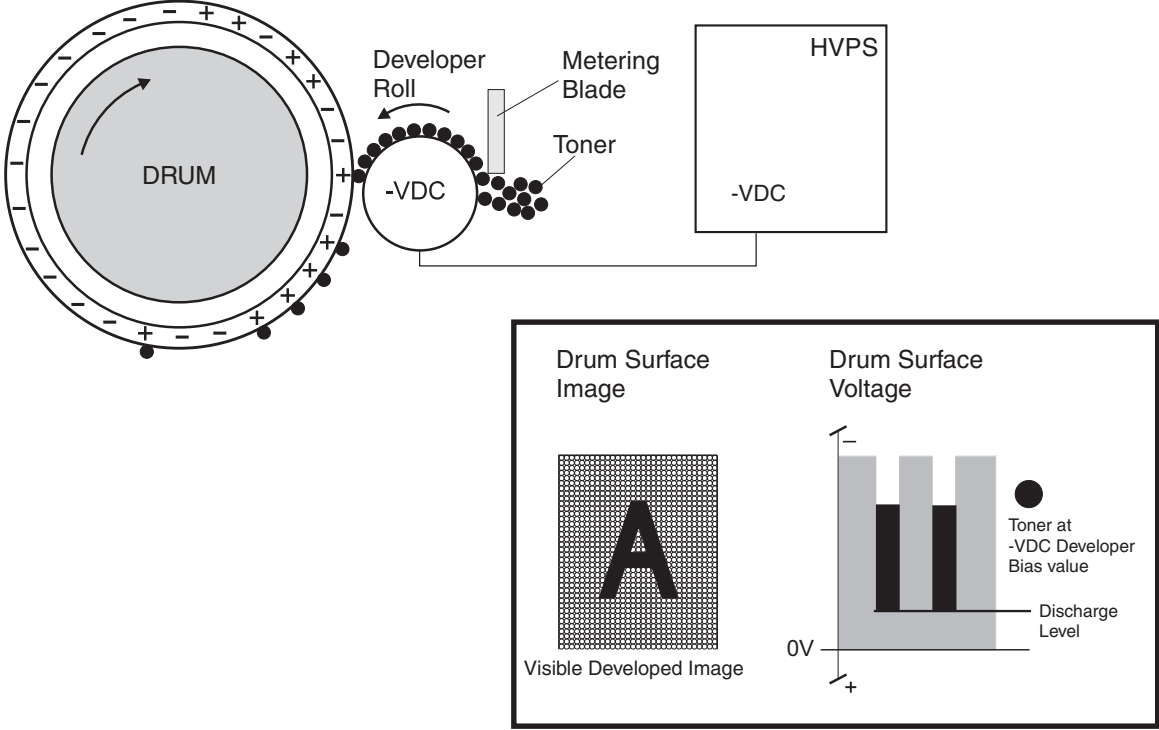

**Transfer**

As the paper travels between the transfer Roll and the photoconductor (drum), the Transfer Roll applies a charge to the back of the printing paper. This positive charge transfers the negative charged toner image from the photoconductor (drum) to the top surface of the paper. The toner image is now on the paper and the paper

is now stuck to the photoconductor (drum) due to the relative electrical differences between the negative electrical charge of the inner conductive layer of the drum and the positive electrical charge of the paper.

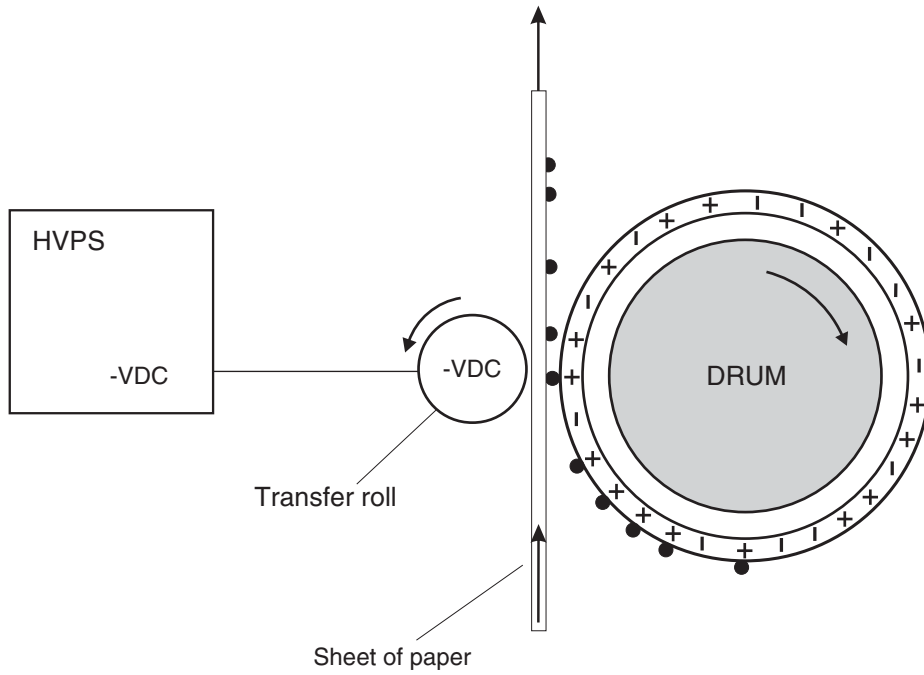

### Cleaning

The Cleaning Blade removes any toner that remains on the drum after the transfer process. The toner that the Cleaning Blade removes is collected inside the sealed PC Cartridge.

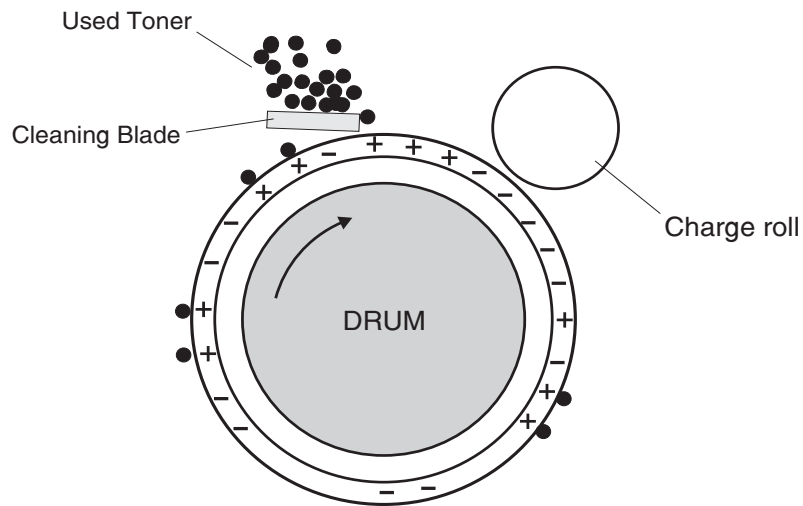

## Auto density sensing

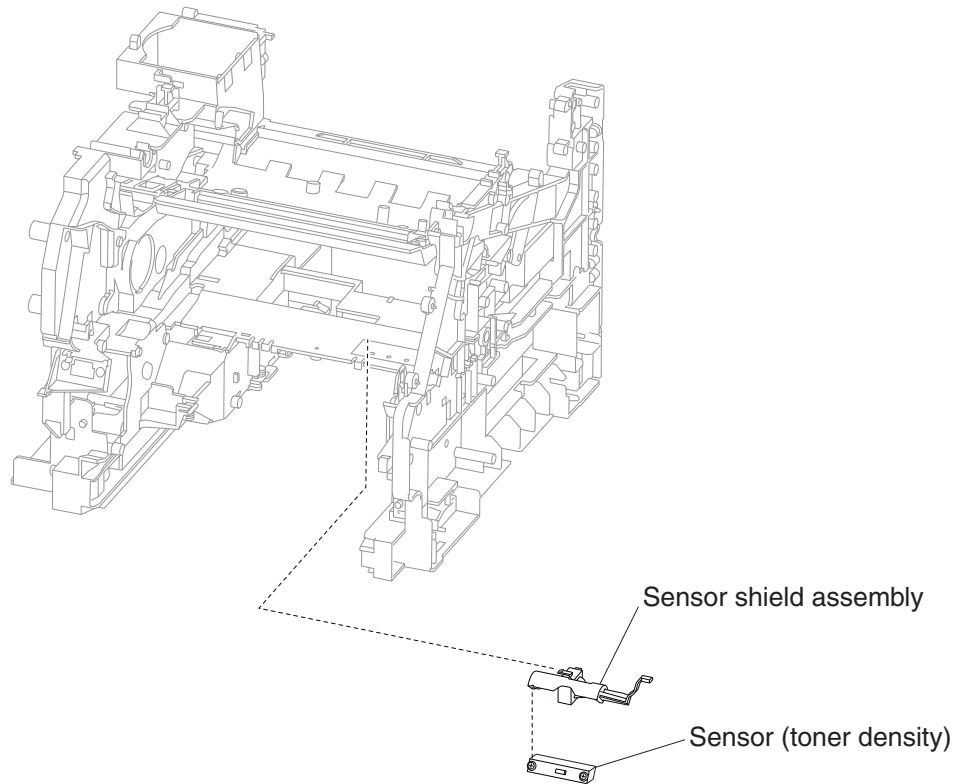

The image density sensor assembly uses a reflection type sensor that detects a pre-placed toner patch and image on the photoconductor (drum) and outputs pulses when the central line of the patch image aligns with the central line of the detector. The sensor outputs pulses at the timing the patch image passes the sensor. Therefore, observing changes of intervals at which pulses are output leads to toner density detection.

### High Capacity Input Tray (HCIT) tray assembly

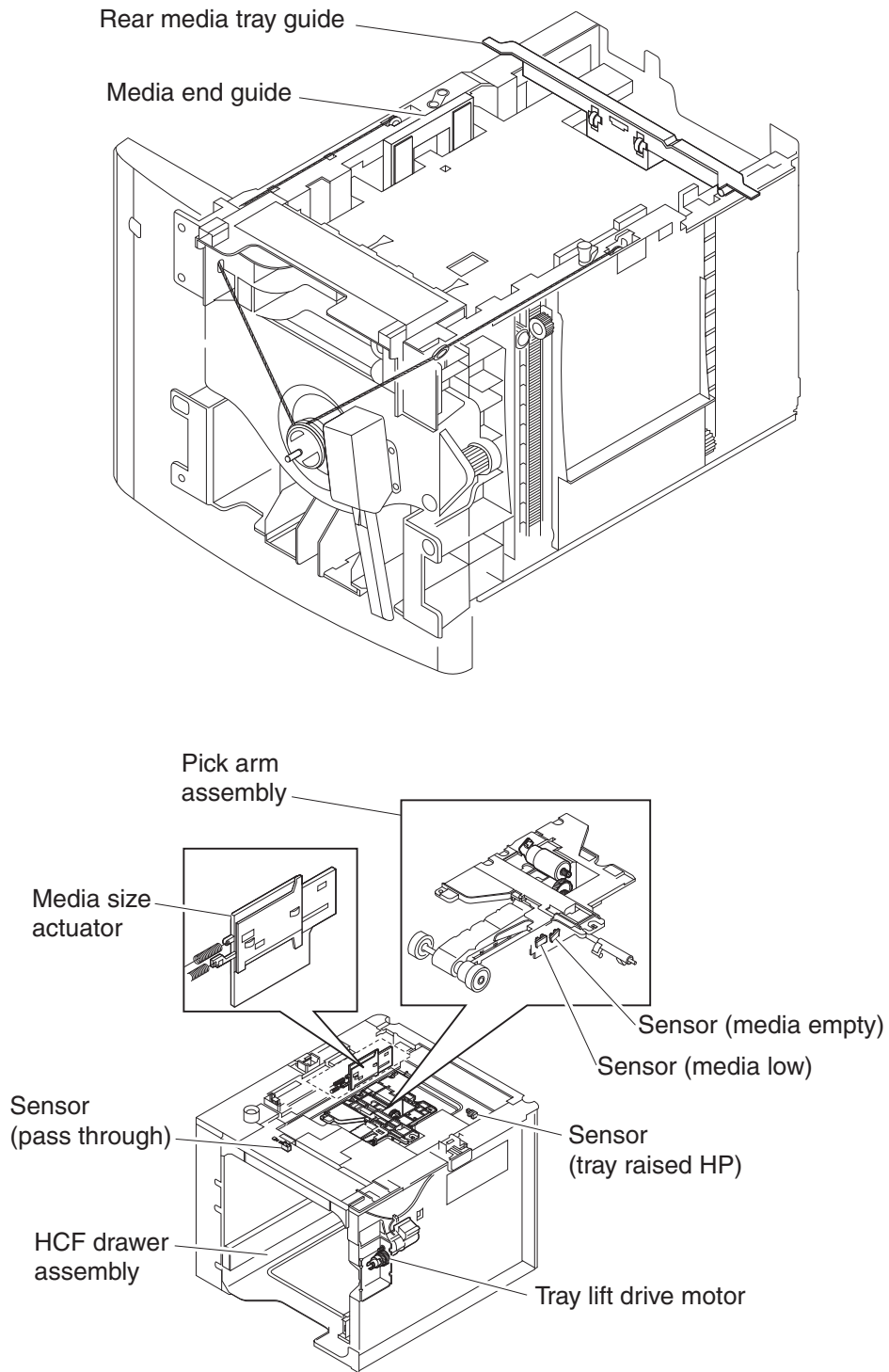

## 250-sheet/550-sheet tray assembly

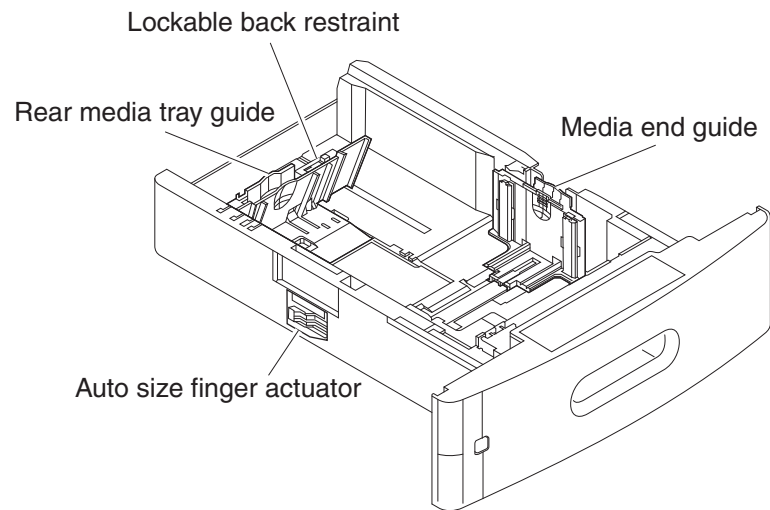

### Media size sensing

The media size set for the media tray assembly is set by positioning the right media guide, unlocking the slider lock, and sliding the rear paper guide. The rear paper guide triggers the movement of the auto size sensing finger, which then sets the switches of the controller card board. The combination of ON/OFF position of the three switches provides information of the media sizes to the engine.

Media size	SW 1	SW 2	SW 3
Unknown	OFF	OFF	OFF
A4	OFF	OFF	ON
Legal	OFF	ON	OFF
B5	OFF	ON	ON
A5	ON	OFF	OFF
Executive	ON	OFF	ON
Letter	ON	ON	OFF
Custom	ON	ON	ON

**Note:** Media size sensing through ON/OFF switch combination

### Media level sensing

The media level for the media tray assembly is triggered by the actuator flag positioned in the two photointerrupter sensors in the pick arm bracket assembly. The actuator flag blocks and unblocks the two sensors in different sequence; it determines whether the paper tray is empty, low, or full.

250-sheet tray	Sensor A	Sensor B
Tray full	unblocked	unblocked
Tray low	blocked	unblocked
Tray empty	blocked	blocked

550-sheet tray	Sensor A	Sensor B
Tray full	unblocked	blocked
Tray low	blocked	blocked
Tray empty	blocked	unblocked

**Note:** Media level sensing through sensor blocking sequence

### Pick arm assembly

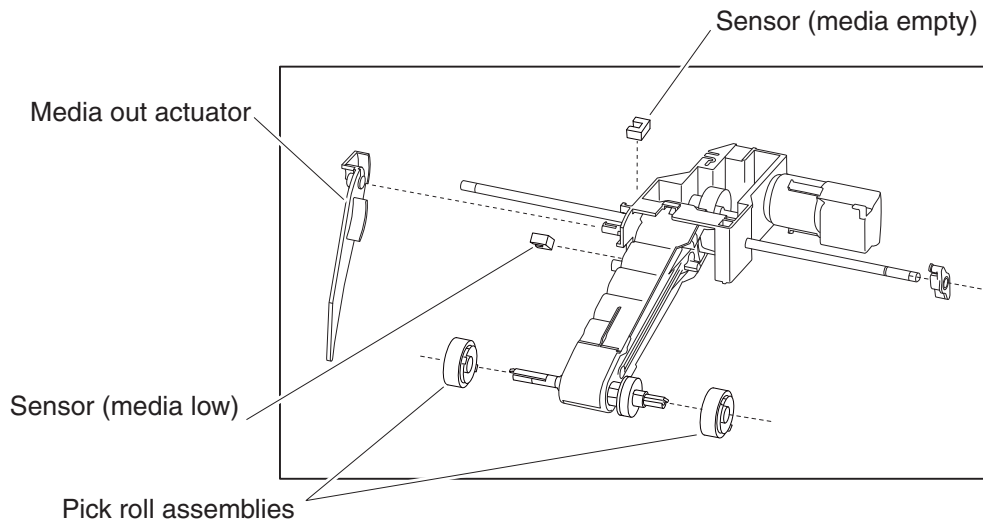

Since all media trays are functionally equivalent in terms of the switch (media size), sensor (media empty), sensor (media low), only the components of one tray are described here.

The pick arm assembly is a mechanical unit supplying media from the media tray assembly to the printer. The driving force, from the pick arm drive motor on the pick arm assembly, is transmitted to the two pick rolls to feed media.

When the pick rolls pick up media, the remaining media decreases, and the media out actuator will lower and interact with the sensor (media low) and sensor (media empty) to determine the amount of media remaining.

The pick arm assembly (autocompensator) is a paper pick device that generates its own normal force. This force generation is inherent in the fundamental design of the pick arm. If light media is used, it picks very gently. If a heavy media is used, it picks very aggressively. No customer adjustments are necessary, therefore no special trays are needed for card stock or labels. The gearing in the arm is designed so the input torque from the motor produces a movement about the pivot of the arm. This movement produces a downward force at the pick rolls. The friction between the pick roll and the paper produces a frictional locking condition. If the paper is physically held and not allowed to feed, then the motor stalls. Slippage between the roll and the paper is theoretically impossible. When the motor is energized, the pick rolls are driven down into the stack, increasing the normal force and drive force until the bending strength of the paper is overcome and the paper bends and moves up the wear strip.

### Switch (media size)

This switch (media size) sets the size of media supplied from each media tray assembly. A signal indicating the media size is transmitted as a voltage to the printer system card assembly.

### Sensor (media empty)

If media runs out in a media tray assembly, the actuator lowers and the actuator flag, unlocks the sensing area of the sensor (media empty). The sensor light is transmitted. When the sensing area is blocked (media is present), the signal is off.

### Sensor (media low)

This sensor detects by the actuator position whether media in the media tray assembly is low. When the flag of the actuator blocks, then unblocks the sensing area of the sensor (media low), the media level is determined to be low.

### Sensor (pass-thru)

A photointerrupter sensor with a built-in flag that sends a signal to the engine where the media from the input tray passes. This will trigger the pick arm to pick the next media.

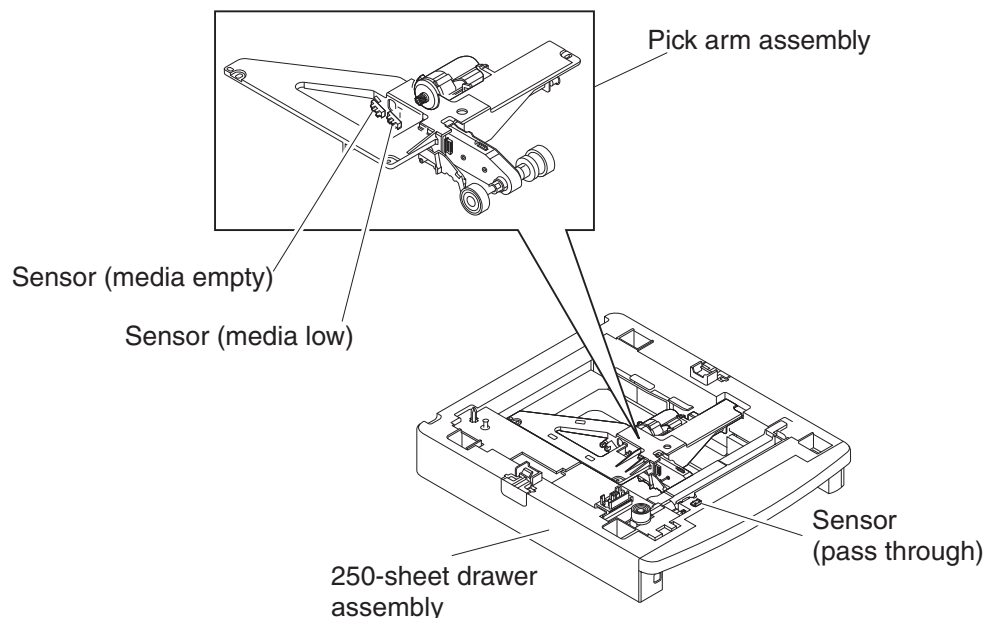

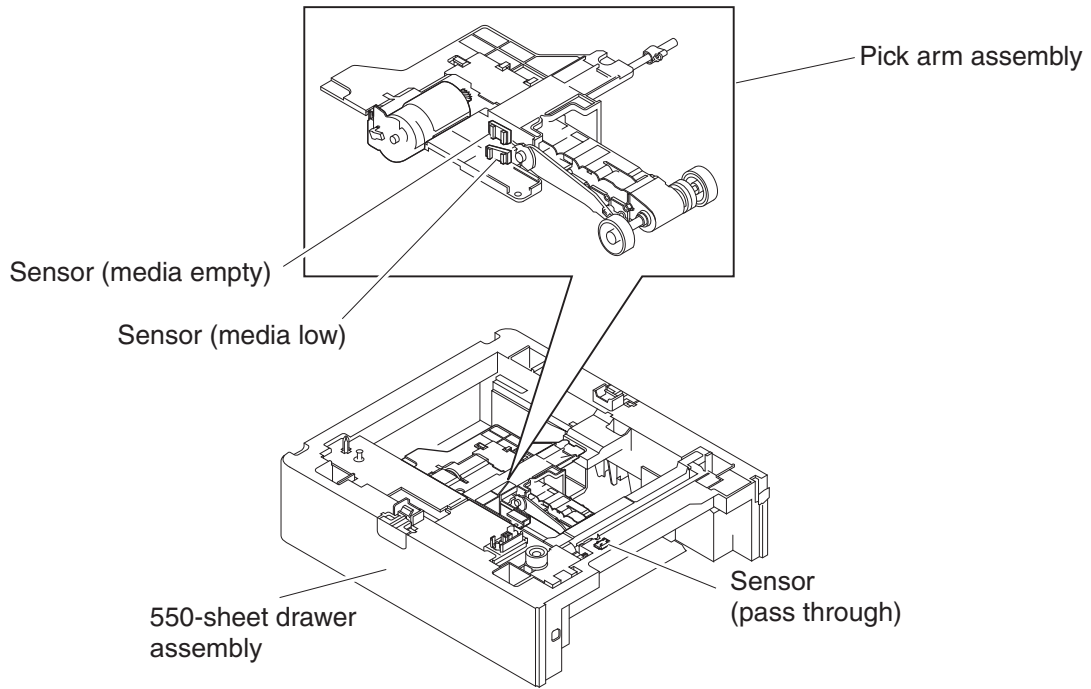



### Media transport path

The following is a cross section of the printer and the tandem tray module, showing the main components directly associated with the media path and transport.

### Model T650 paper path, rolls, and sensors

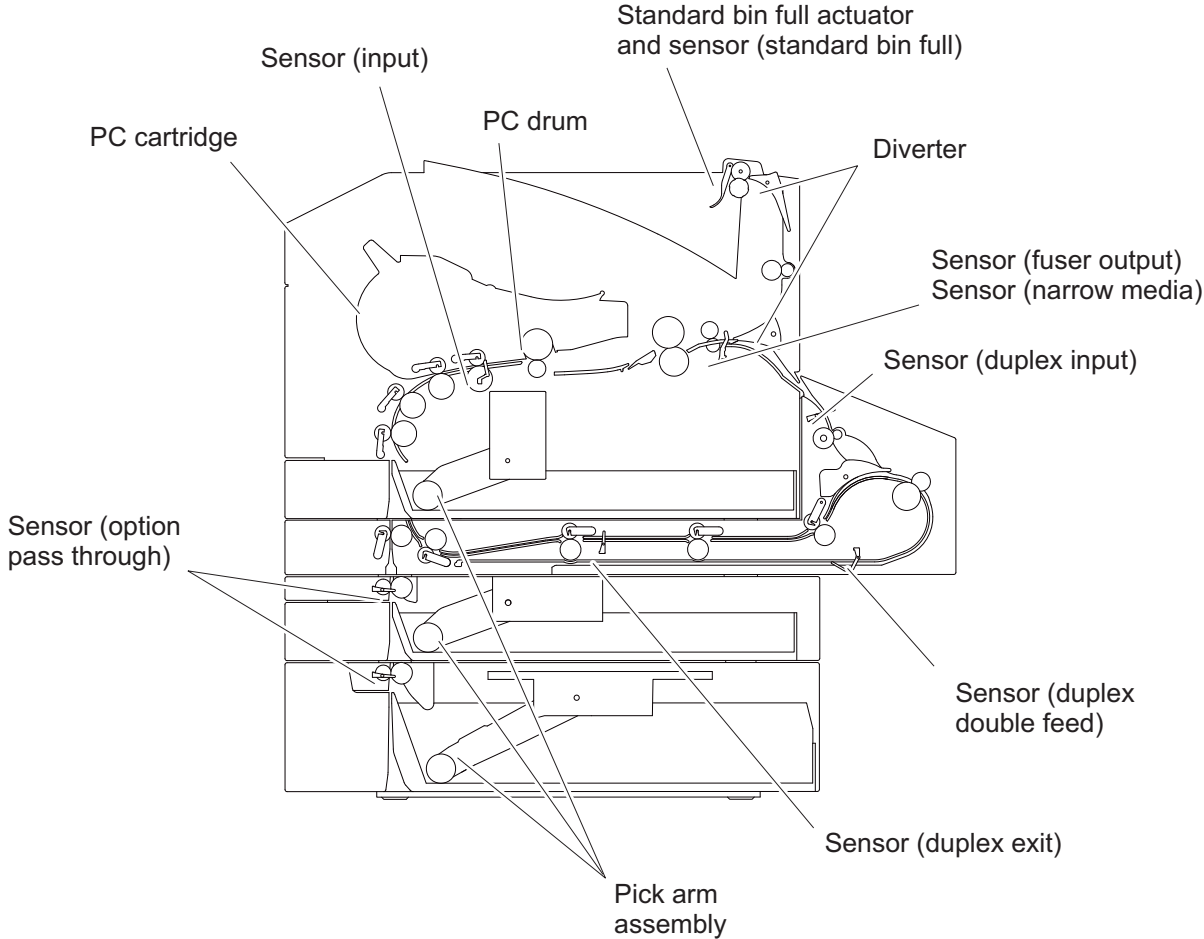

## Models T652 and T654 paper path, rolls, and sensors

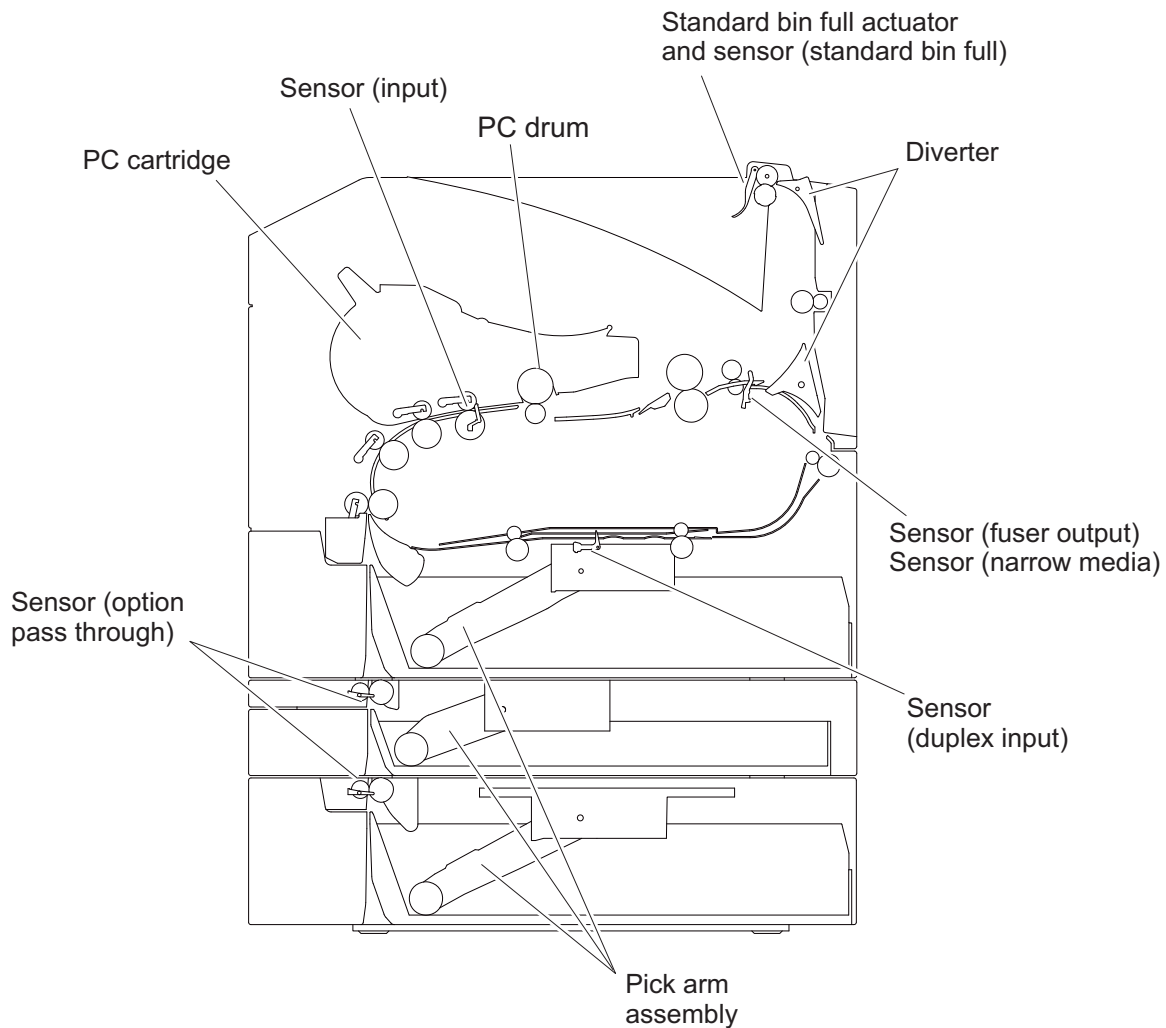

### Functions of main components

When the 250 or 550 sheet input trays are installed under the printer, additional trays are available.

### Media tray assembly

It is necessary to adjust the media tray rear guide and media tray side guide of the media tray assembly to match the media size.

### Rear media guide

The rear media tray guide assembly can be adjusted to different media sizes by moving it to the front or rear. The rear guide should come into contact with the media and hold it in position.

### Side guide

The media tray assembly is designed so it can adapt to the media width in the media feed direction by moving the side guide to the left or right.

## Wear strips

The wear strips are designed to provide a fixed resistance to ensure that a single piece of paper is properly fed out of the media tray. There are several types of wear strips available for custom or hard to feed media.

## Media tray assembly

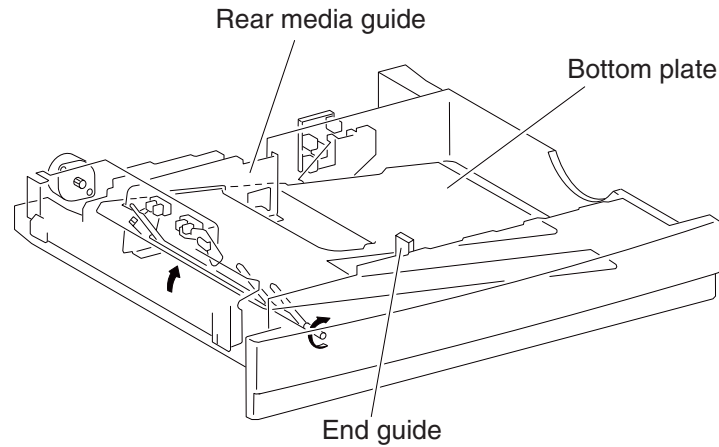

## Detection of media size

The media size set for the media tray assembly is transmitted to the switch (media size) by moving these guides. The media size is detected by the on/off information of these switches.

## Pick arm assembly

Since all media trays are functionally equivalent in terms of the switch (media size), sensor (media empty), sensor (media low), only the components of one tray are described here.

The pick arm assembly is a mechanical unit supplying media from the media tray assembly to the printer. The driving force, from the pick arm drive motor on the pick arm assembly, is transmitted to the two pick rolls to feed media.

When the pick rolls pick up media, the remaining media decreases, and the media out actuator will lower and interact with the sensor (media low) and sensor (media empty) to determine the amount of media remaining.

The pick arm assembly (autocompensator) is a paper pick device that generates its own normal force. This force generation is inherent in the fundamental design of the pick arm. If light media is used, it picks very gently. If a heavy media is used, it picks very aggressively. No customer adjustments are necessary, therefore no special trays are needed for card stock or labels. The gearing in the arm is designed so the input torque from the motor produces a movement about the pivot of the arm. This movement produces a downward force at the pick rolls. The friction between the pick roll and the paper produces a frictional locking condition. If the paper is physically held and not allowed to feed, then the motor stalls. Slippage between the roll and the paper is theoretically impossible. When the motor is energized, the pick rolls are driven down into the stack, increasing the normal force and drive force until the bending strength of the paper is overcome and the paper bends and moves up the wear strip.

## Switch (media size)

This switch (media size) sets the size of media supplied from each media tray assembly. A signal indicating the media size is transmitted as a voltage to the printer system card assembly.

## Sensor (media empty)

If media runs out in a media tray assembly, the actuator lowers and the actuator flag, unlocks the sensing area of the sensor (media empty). The sensor light is transmitted. When the sensing area is blocked (media is present), the signal is off.

**Sensor (media low)**

This sensor detects by the actuator position whether media in the media tray assembly is low. When the flag of the actuator blocks, then unblocks the sensing area of the sensor (media low), the media level is determined to be low

Tray 2 media tray assembly

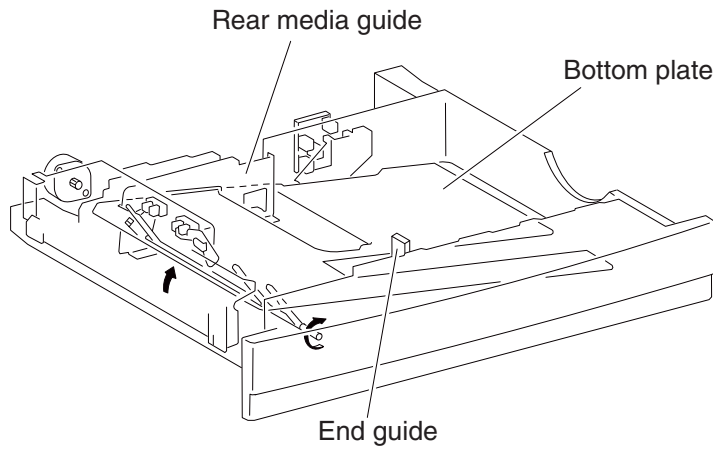

**Note:**

Media Size	Analog switch	
	S/W1	S/W3
No Tray	Off	Off
B5L/7.25" x 10.5"L	Off	On
8.5" x 11"L	On	Off
A4L	On	On

# Duplex

## Layout of media transport path

The main components associated with the media path and transport with the duplex installed.

### Model T650 duplex paper path

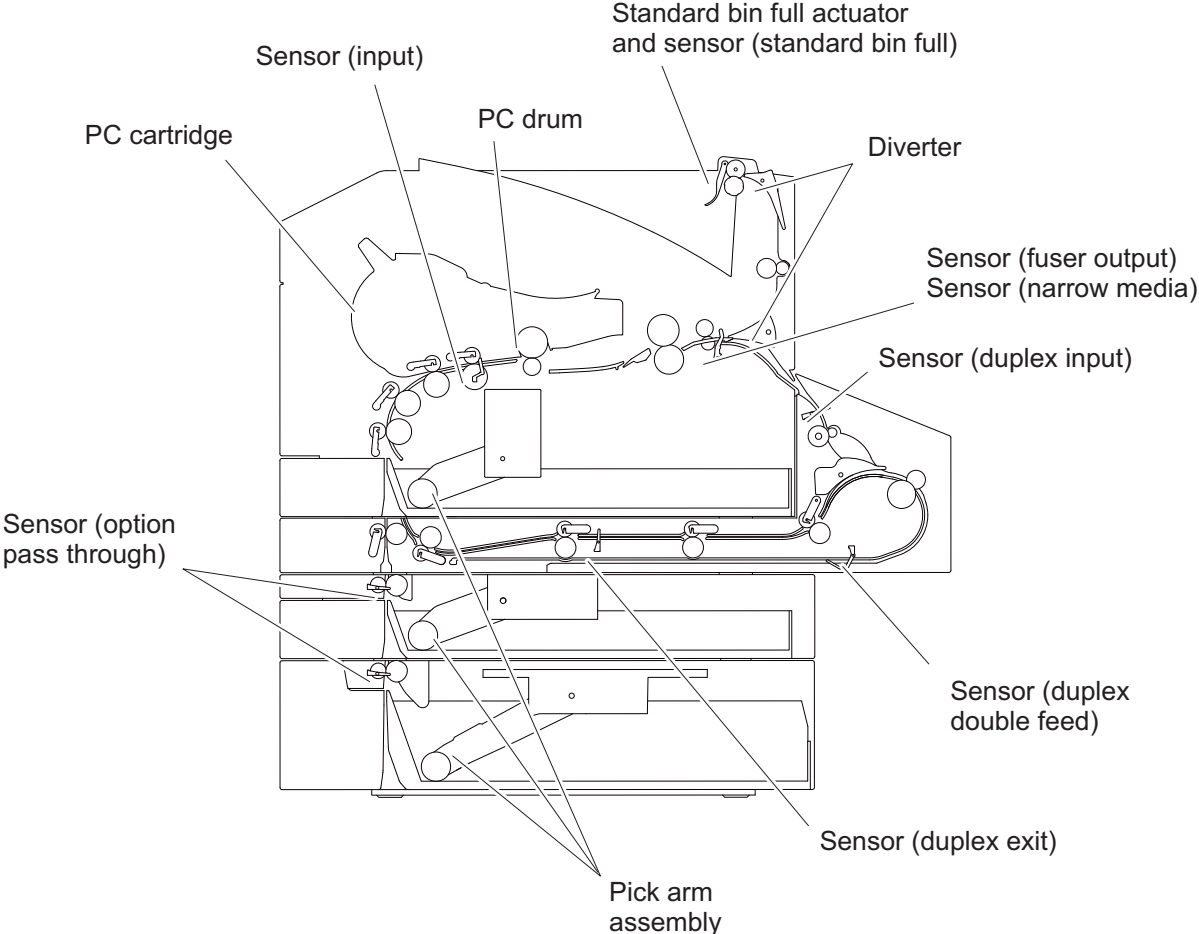

**Models T652 and T654 duplex paper path**

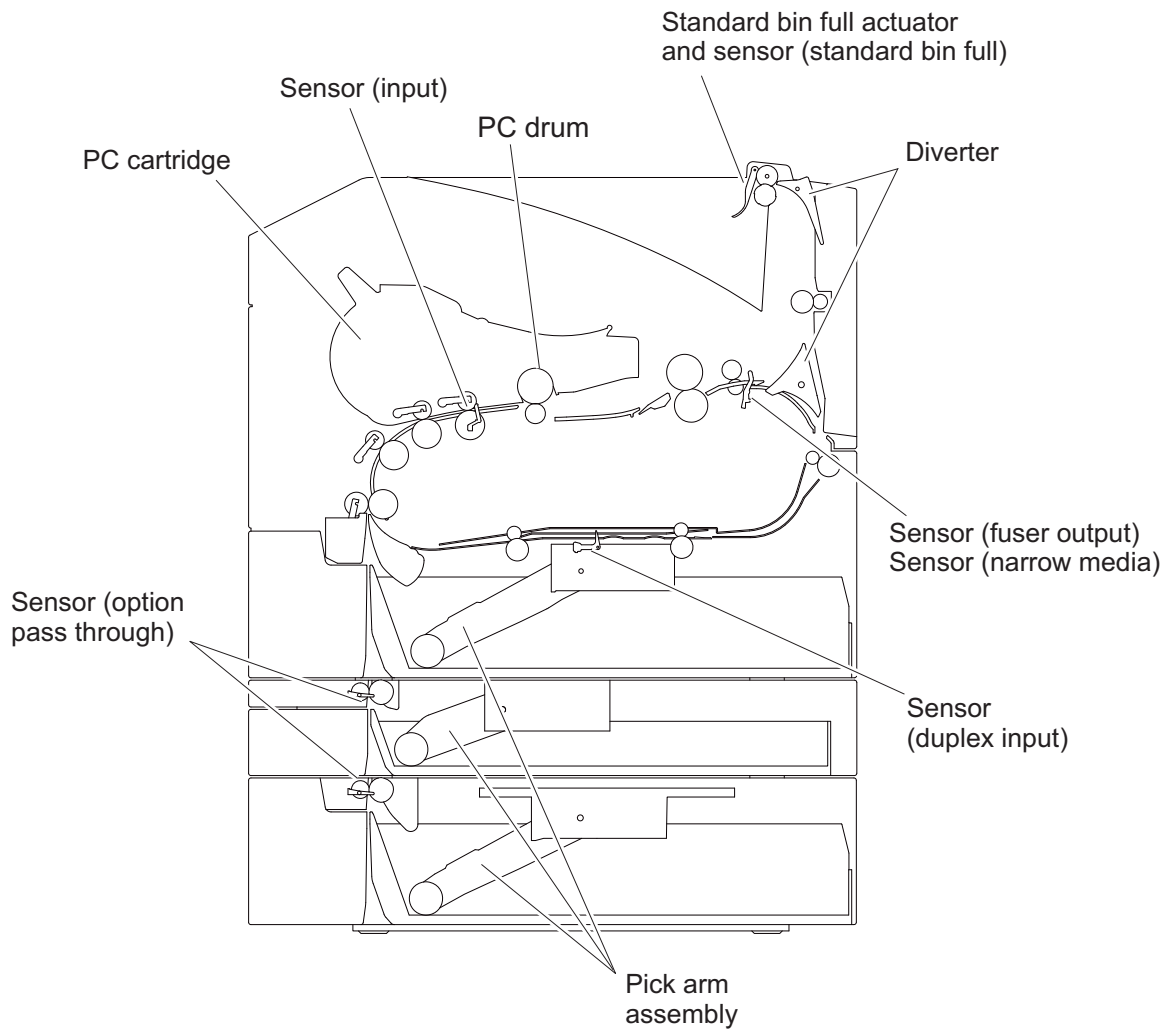

**Functions of main components**

When the duplex is installed, duplex (double-sided) printing is available with the printer.

The following outlines the functions of the main components of the duplex.

**Sensor (duplex input)**

The sensor (duplex wait) detects whether media is remaining in the duplex.

### Duplex drive motor assembly

The duplex drive motor assembly transmits driving force to the two duplex media transport roll assemblies and the duplex media center transport roll assembly middle that feeds media.

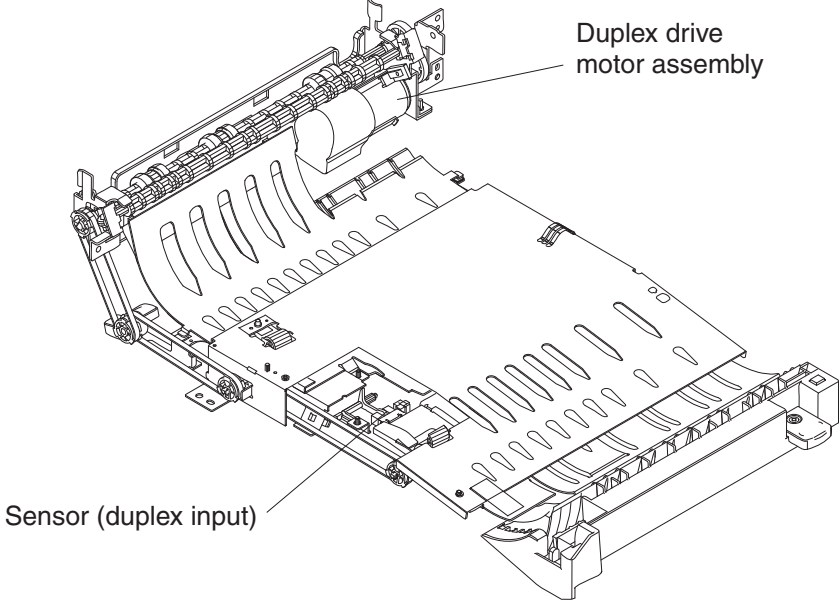

## Understanding jam numbers and locations

When a jam occurs, a message indicating the jam location appears. Open doors and covers and remove trays to access jam locations. To resolve any paper jam message, you must clear all jammed paper from the paper path.

The following table lists the jams that can occur and the location of each jam:

Jam numbers	Area
200–203	Printer
230–239	Duplex unit
241–245	Paper trays
250	Multipurpose feeder
260	Envelope feeder
270–279	Optional output bins
28x	Stapler

### 200 and 201 paper jams

1. Push the release latch, and then lower the multipurpose feeder door.
2. Push the release latch, and then open the front cover.

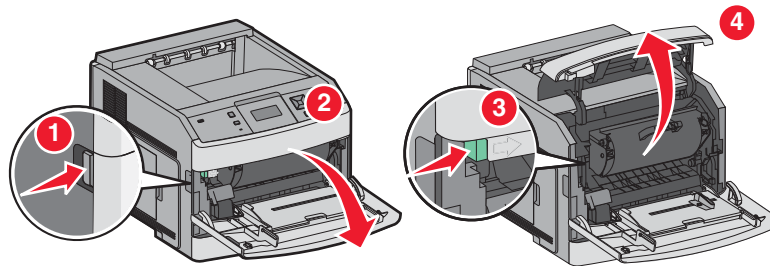

3. Lift and pull the print cartridge out of the printer.

**WARNING:** Do not touch the photoconductor drum on the underside of the cartridge. Use the cartridge handle whenever you are holding the cartridge.

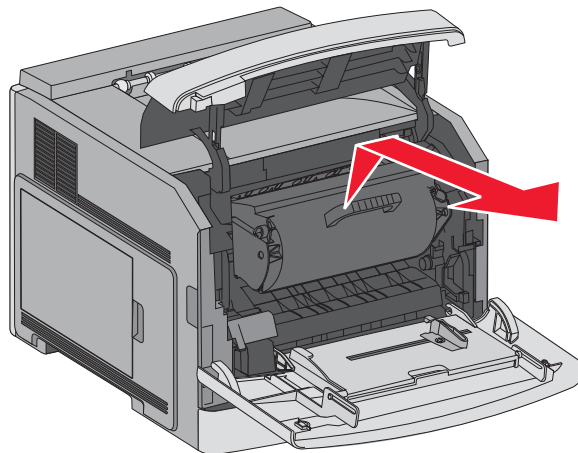

4. Place the print cartridge aside on a flat, smooth surface.



**WARNING:** Do not leave the cartridge exposed to light for extended periods.

**WARNING:** The jammed paper may be covered with unfused toner which can stain garments and skin.

5. Remove the jammed paper.



**CAUTION:** The inside of the printer might be hot. To reduce the risk of injury from a hot component, allow the surface to cool before touching.

**Note:** If the paper is not easy to remove, then open the rear door and remove the paper from there.

6. Align and reinstall the print cartridge.
7. Close the front cover.
8. Close the multipurpose feeder door.
9. Press .

### ***202 and 203 paper jams***

If the paper is exiting the printer, then pull the paper out, and then press .

If the paper is not exiting the printer:

1. Pull down the top rear door.

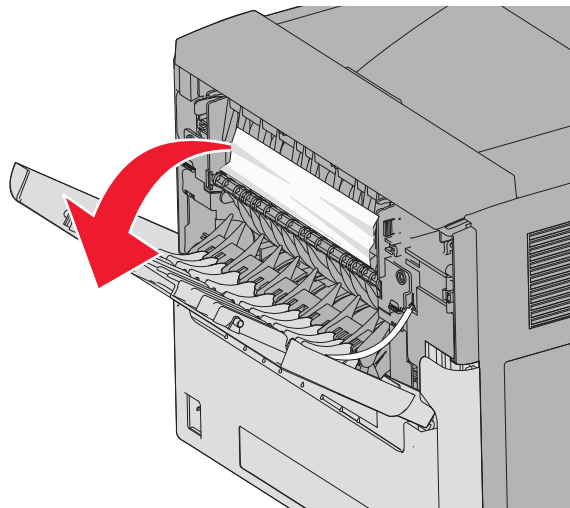

2. Slowly remove the jammed paper to avoid tearing it.
3. Close the top rear door.
4. Press .

## 230 paper jam

### Rear paper jams

1. Remove the standard tray from the printer.

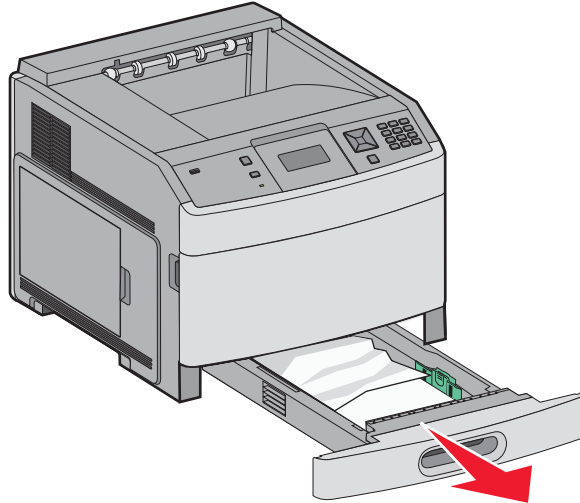

2. Pull down the bottom rear door.

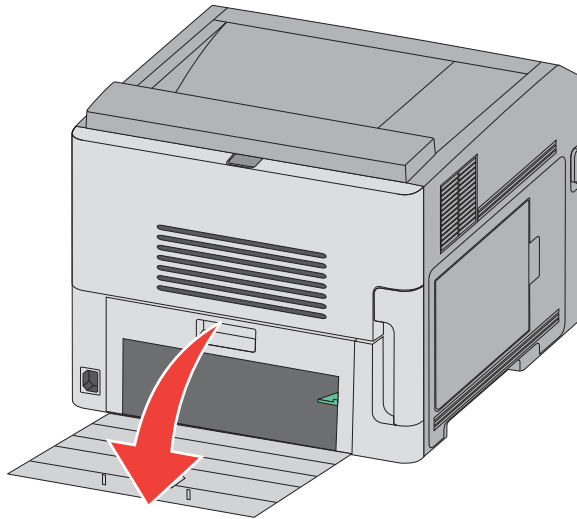

3. Push the tab down.

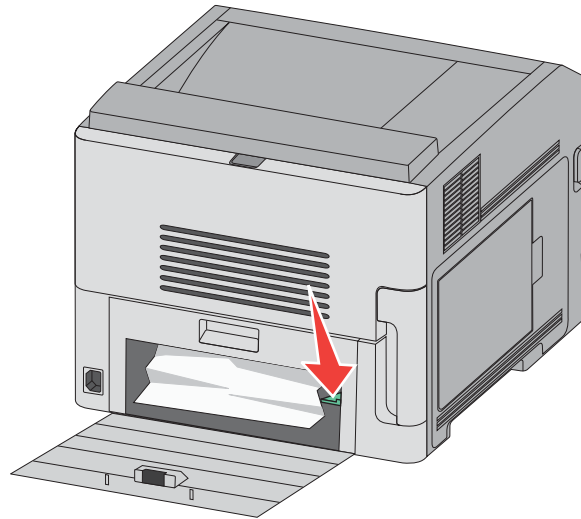

4. Remove the jammed paper.
5. Close the bottom rear door.
6. Insert the standard tray.
7. Press .

### Front paper jams

1. Remove the standard tray from the printer.
2. Push the tab down.

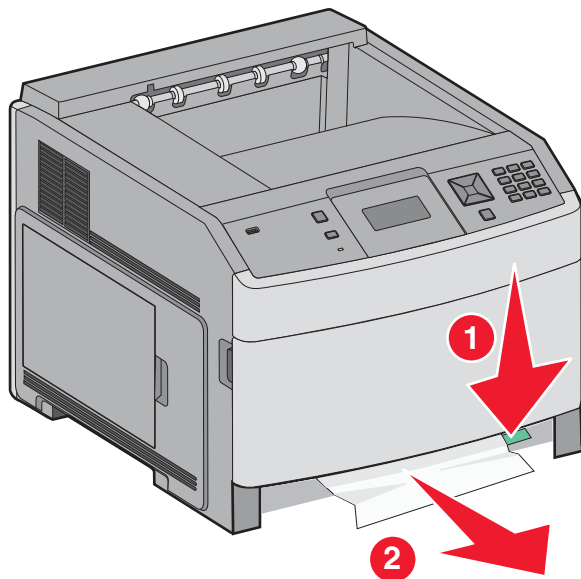

3. Remove the jammed paper.
4. Insert the standard tray.
5. Press .

## 231-239 paper jams (optional external duplex unit)

### Rear paper jams

1. Push in and hold the latch while pulling up the rear duplex door.

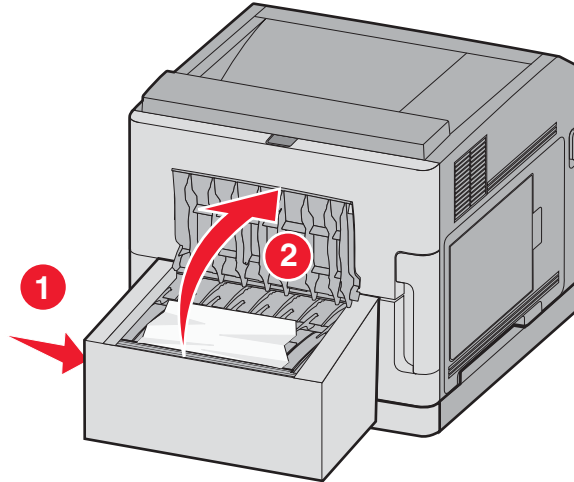

2. Remove the jammed paper.
3. Close the rear duplex door.
4. Press .

### Front paper jams

1. Remove the standard tray from the printer.
2. Remove the duplex jam access tray.

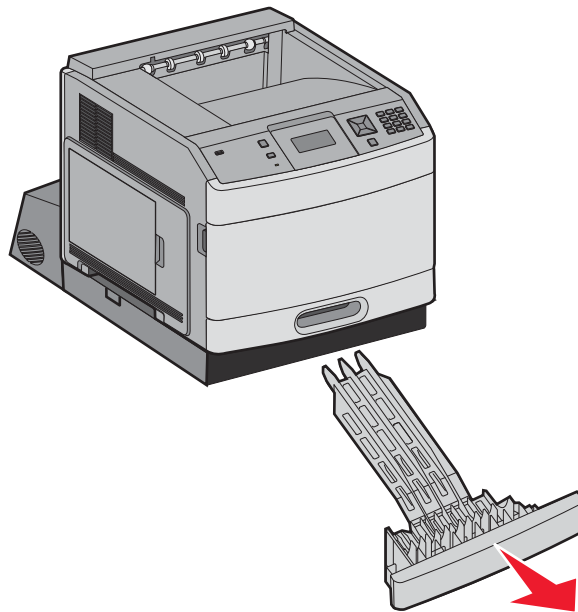

3. Raise the recessed duplex bar.

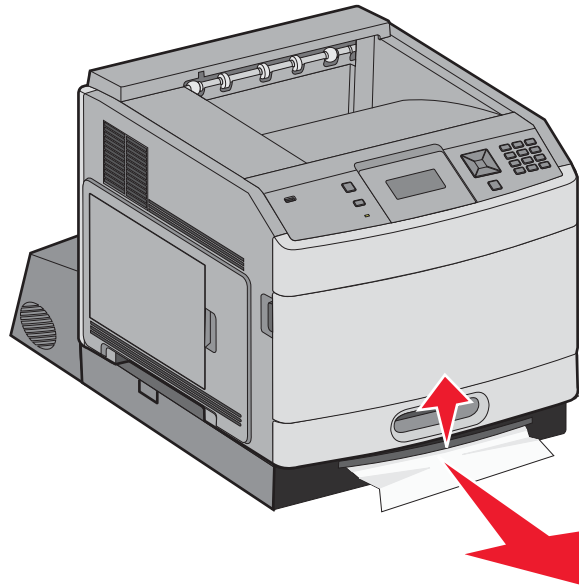

4. Remove the jammed paper.
5. Replace the duplex jam access tray.
6. Insert the standard tray.
7. Press .

### **241–245 paper jams**

1. Pull out the tray indicated on the display.

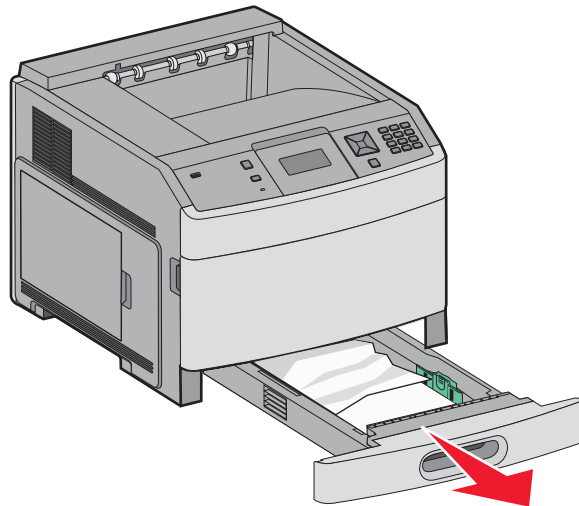

2. Remove any jammed paper, and then insert the tray.
3. Press .
4. If the jam message remains for a 250-sheet or 550-sheet tray, then remove the tray from the printer.
5. Remove the jammed paper, and then insert the tray.
6. Press .

## 250 paper jam

1. Remove the paper from the multipurpose feeder.

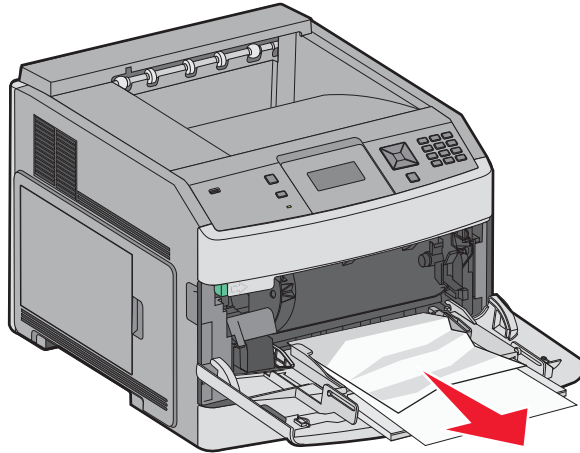

2. Flex the sheets of paper back and forth to loosen them, and then fan them. Do not fold or crease the paper. Straighten the edges on a level surface.
3. Load the paper into the multipurpose feeder.
4. Slide the paper guide toward the inside of the tray until it lightly rests against the edge of the paper.

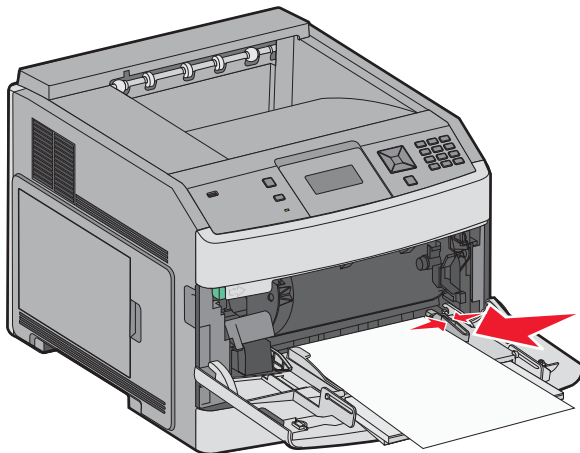

5. Press .

## 260 paper jam

The envelope feeder feeds envelopes from the bottom of the stack; the bottom envelope will be the one that is jammed.

1. Lift the envelope weight, and then remove all the envelopes.

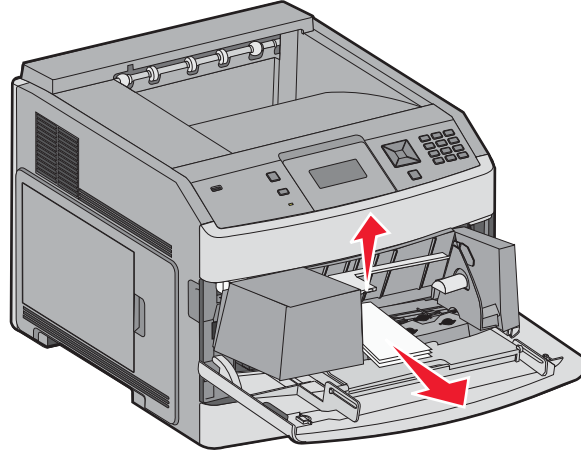

2. If the jammed envelope has entered the printer and cannot be pulled out, then lift the envelope feeder up and then out of the printer, and then set it aside.
3. Remove the envelope from the printer.

**Note:** If you cannot remove the envelope, the print cartridge will have to be removed. For more information, see **“200 and 201 paper jams” on page 3-96**.

4. Reinstall the envelope feeder. Make sure it *snaps* into place.
5. Flex and stack the envelopes.
6. Load the envelopes in the envelope feeder.
7. Adjust the paper guide.
8. Lower the envelope weight.
9. Press .

## 271–279 paper jams

To clear a jam in the output expander, high-capacity output stacker, the 5-bin mailbox, or the StapleSmart II Finisher:

1. If the paper is exiting into a bin, then pull the paper straight out, and then press . If not, then continue with step 2.
2. Pull down the output bin door or doors.
3. Remove the jammed paper.
4. Close the output bin door or doors.
5. Press .

## 280 paper jam

1. Pull down the StapleSmart II Finisher door.

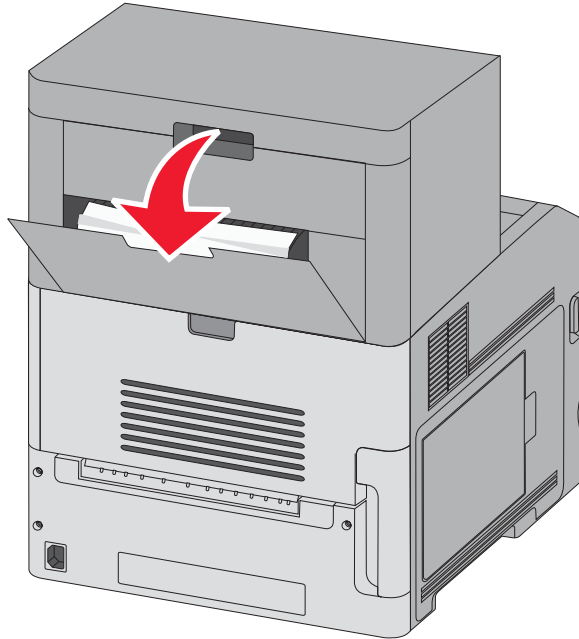

2. Remove the jammed paper.
3. Close the StapleSmart ii Finisher door.
4. Press .



### 281 paper jam

1. Clear the jam from the stapler output bin.

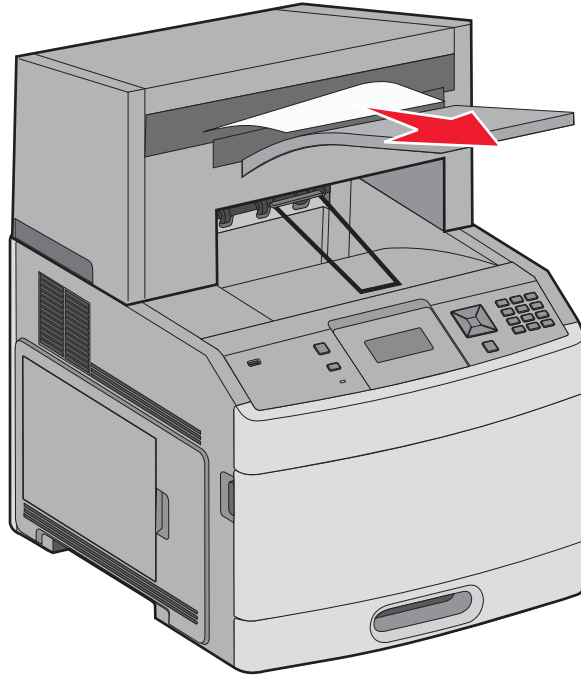

2. Press .

### 282 paper jam

To prevent paper jams, the stapler motor does not run when the stapler door is open.

1. Close the stapler door until it *clicks* into place.

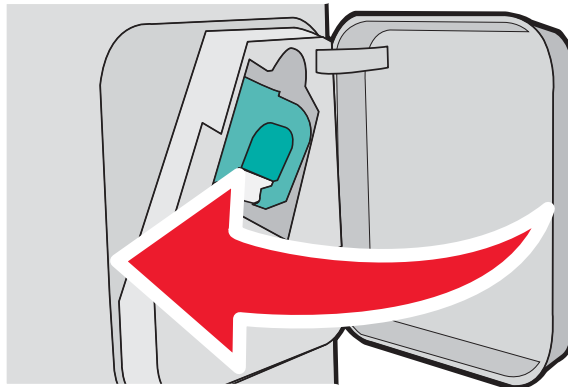

2. Press .

## 283 staple jam

1. Press the latch to open the stapler door.

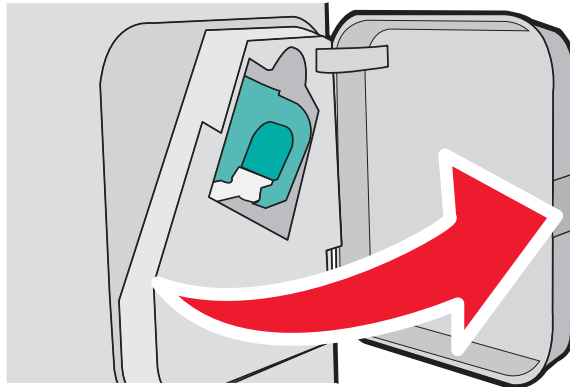

2. Pull the latch of the staple cartridge holder down, and then pull the holder out of the printer.

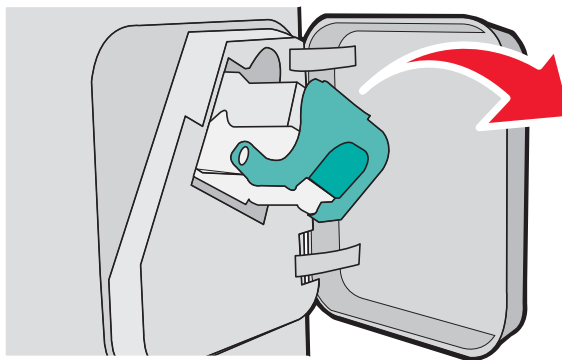

3. Use the metal tab to lift the staple guard, and then remove any loose staples.

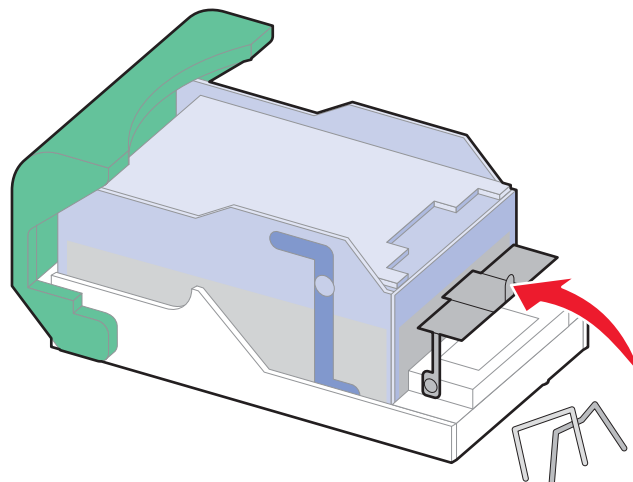

4. Press down on the staple guard until it *snaps* into place.

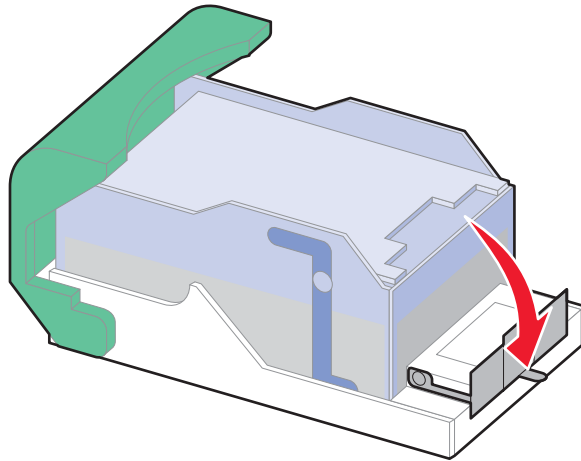

5. Push the cartridge holder firmly back into the stapler unit until the cartridge holder *clicks* into place.
6. Close the stapler door.
7. Press .

---

## Security Reset Jumper

The Security Reset Jumper is available on all high-end printer and MFP models, including the T650, T652, T654, X652, X654, X656, and X658. It functions as described below (excerpt from the RIP Functional Spec):

### *Security Reset Jumper*

Each device contains a hardware jumper with which an administrator can:

- Erase all security templates, building blocks, and access controls that a user has defined (i.e. the factory default configuration); or
- Force the value of each function access control to “No Security” (all security templates and building blocks are preserved but not applied to any function).

**Note:** Note: If the “Enable Audit ” setting in the Security Audit Log section of the “Security Menu ” is activated, the device logs a message each time that the jumper is used.

A small lock icon identifies the jumper’s position on the RIP card. Also, to make it easier to separate the small yellow plastic jumper from the 3-pin connector, a looped handle is attached to the top of the small yellow jumper that covers the 3-pin connector.

An administrator controls how a jumper reset affects a device by configuring the jumper-related setting on the Security Web page.

**Note:** Administrators can discourage tampering with the jumper by securing the entire RIP card cage (of which the jumper is a part) with a Kensington lock. or, to completely negate the effects of a jumper reset, an administrator can select the “No Effect ” value for the jumper-related setting on the Security Web page or in the “Security Reset Jumper ” setting in the “ Security Menu”.

To perform a jumper reset operation:

1. Power the device off.
2. Remove the Kensington lock from the card cage (if installed).

- Remove the small yellow jumper that covers a pair of the jumper's pins.

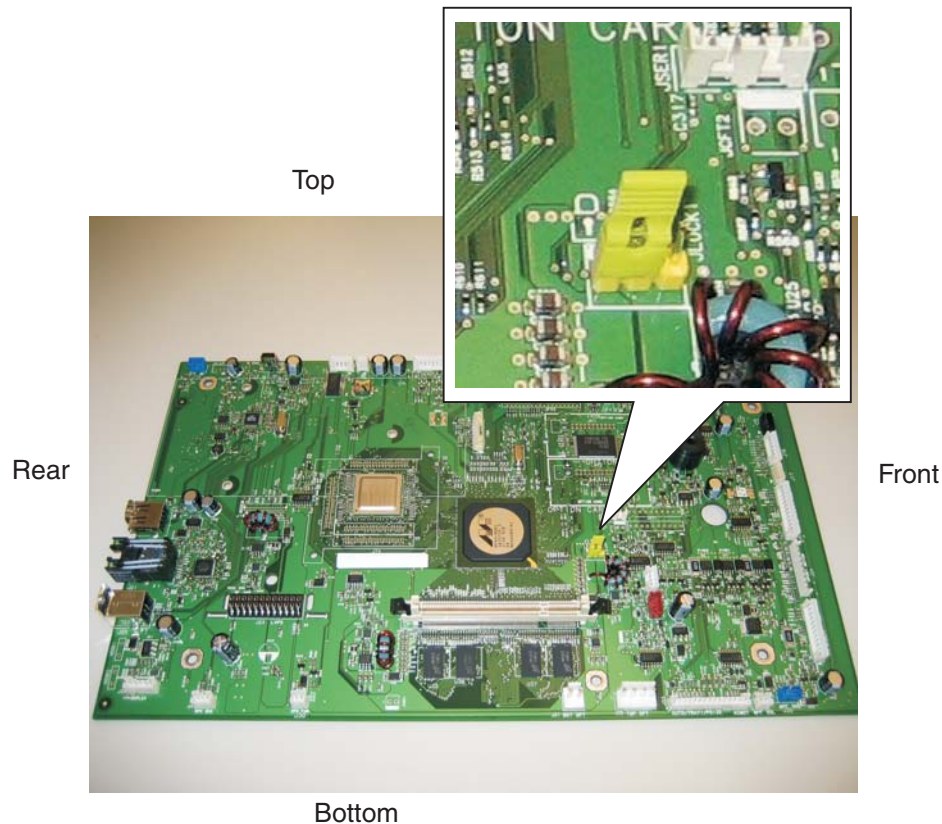

- Replace the small yellow jumper so that it covers the pins adjacent to its original position.
- Replace and secure the Kensington lock on the card cage (if installed).
- Power the device on.

**Note:** The movement of the small yellow jumper from position A to position B triggers the reset, not the specific positions. When the device is powered on, it labels the current position of the small yellow jumper (let's say position A) as the "home" position. If, at the next POR, the device detects that the small yellow jumper has moved from its previous "home" position (position A) to the "other" position (position B), then it performs a jumper reset. After performing the reset, the device also relabels the "other" position (position B) as the "home" position (now position A is the "other" location).

**Note:** The admin's security settings are lost when the RIP card is replaced. Secure settings are those that are configured under the Settings->Security->Edit Security Setups menu. These are all the PINs, Passwords, and other Building Blocks and Security Templates that define the device's protection of functions and menus. In other words, if the customer is using LDAP to authenticate users to use the Copy function, then after the RIP card is replaced, the device will no longer have that LDAP configuration or the Copy function protected.



## 4. Repair Information

**WARNING:** Read the following before handling electronic parts.

---

### Handling ESD-sensitive parts

Many electronic products use parts that are known to be sensitive to electrostatic discharge (ESD). To prevent damage to ESD-sensitive parts, follow the instructions below in addition to all the usual precautions, such as turning off power before removing logic boards:

- Keep the ESD-sensitive part in its original shipping container (a special "ESD bag") until you are ready to install the part into the machine.
- Make the least-possible movements with your body to prevent an increase of static electricity from clothing fibers, carpets, and furniture.
- Put the ESD wrist strap on your wrist. Connect the wrist band to the system ground point. This discharges any static electricity in your body to the machine.
- Hold the ESD-sensitive part by its edge connector shroud (cover); do not touch its pins. If you are removing a pluggable module, use the correct tool.
- Do not place the ESD-sensitive part on the machine cover or on a metal table; if you need to put down the ESD-sensitive part for any reason, first put it into its special bag.
- Machine covers and metal tables are electrical grounds. They increase the risk of damage, because they
- a discharge path from your body through the ESD-sensitive part. (Large metal objects can be discharge paths without being grounded.)
- Prevent ESD-sensitive parts from being accidentally touched by other personnel. Install machine covers when you are not working on the machine, and do not put unprotected ESD-sensitive parts on a table.
- If possible, keep all ESD-sensitive parts in a grounded metal cabinet (case).
- Be extra careful in working with ESD-sensitive parts when cold-weather heating is used, because low humidity increases static electricity.

---

## Adjustments

### Polygon and Oscillating printhead mechanical registration adjustment

Do the printhead mechanical registration adjustment whenever you remove or replace the printhead or loosen the mounting screws.

Install the new printhead with the mounting screws centered in the slots in the printhead frame assembly. Leave the screws loose enough to allow the printhead to move from side to side within the slots. It is necessary to perform a mechanical registration adjustment before locking down the three printhead mounting screws.

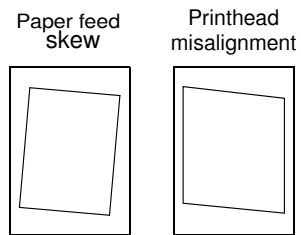

**Note:** In the case of paper feed skew, go to **“Alignment assembly adjustment”** on page 4-4.

To perform the mechanical registration adjustment:

1. Turn the printer off.
2. Press and hold ▼ and to enter the diagnostic mode.
3. Turn the printer on, and release the buttons when Performing Self Test displays.
4. Select **Registration** from the menu.



- Select **Quick Test Page**. The test page should only be printed on letter or A4 paper from Tray 1. The Quick Test Page consists of alignment diamonds, horizontal lines that can be used for mechanical registration adjustment. An example of the printhead alignment printout is shown below:

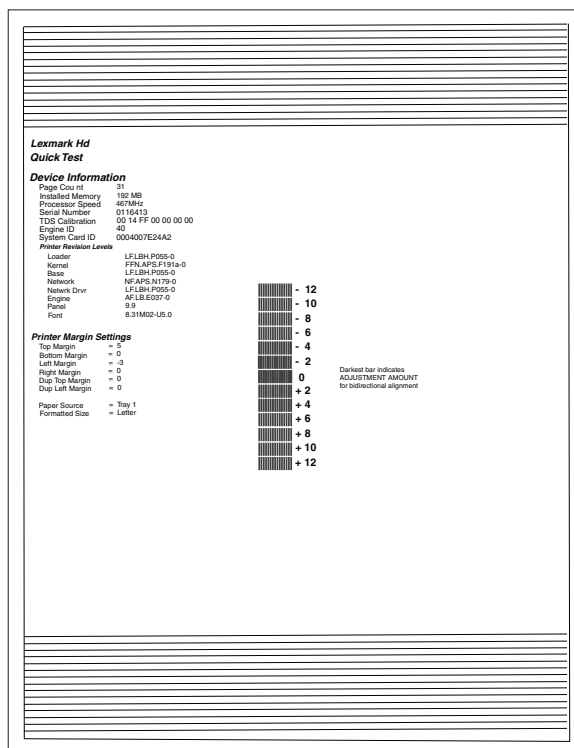



- Check the Quick Test Page for any sign of misalignment by checking the diamonds at the top left and top right of the test page for equal distance from the top of the page. If necessary, rotate the printhead to the left or right and tighten down the mounting screws and check for proper alignment again by running another Quick Test Page. This procedure may take two or three attempts before you get satisfactory results.
- When you have the correct adjustment, ensure that the printhead mounting screws are properly tightened.

## Oscillating printhead assembly electronic adjustment

A step-by-step process to align a new printhead.

**Note:** Before aligning the printhead electronically, first align the printhead mechanically, if needed. Go to **“To perform the mechanical registration adjustment:” on page 4-2.**

- Turn the printer off.
- Press and hold  and  to enter the diagnostic mode.
- Turn the printer on, and release the buttons when Performing Self Test displays.
- Select **Registration** from the menu.
- Select **Quick Test Page**. The test page should only be printed on letter or A4 paper from Tray 1. The Quick Test Page consists of alignment diamonds, horizontal lines that can be used for skew adjustment, page count setting, printer serial number code levels, and print registration settings. An example of the printhead

alignment printout is shown below:

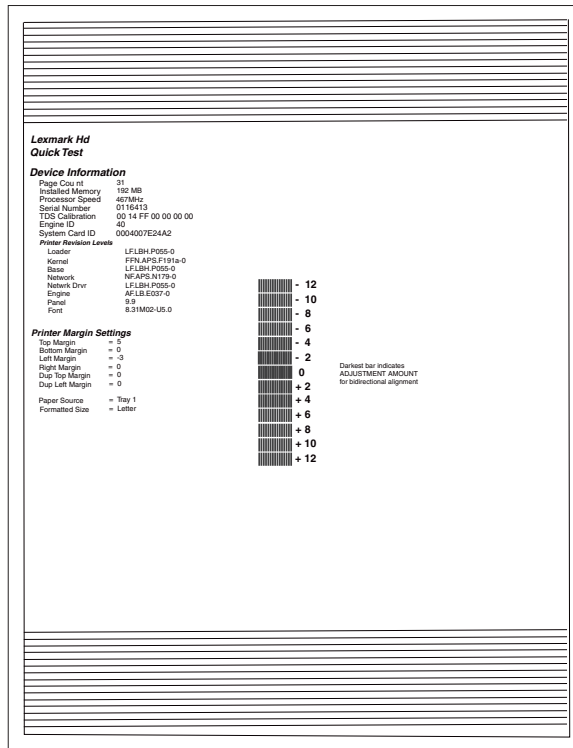

6. In the Registration menu, select the right margin setting.
7. To determine the margin setting, choose the value that is closest to the darkest bar on the center graph of the margin page. Add that value to the current right margin setting printed on the left hand side of the margin page. (The right margin setting will also appear on the operator panel display.) For example, if the right margin setting on the page is -2, and the number that is closest to the darkest line on the graph is 3 (-2+3), then the right margin setting will be equal to +1.
8. Press ▼ or ▲ to the desired setting, and press .
9. Print the Quick Test page again and check that the darkest line in the center graph is equal to zero. If it is, then check to see if the left, top, and bottom margins are detected. If it is not, then repeat step 5.

**Note:** The alignment of the left margin positions the black plane to the right or left. The alignment of the right margin does not alter the margins and should only be used to adjust the printhead.

## Alignment assembly adjustment

Do the alignment assembly adjustment whenever you replace the alignment assembly. Always print a copy of the Quick Test Page before making any adjustments to the alignment assembly reference adjustment screw. When replacing the alignment assembly, it is necessary to back the reference adjustment screw out far enough to remove the old assembly and install the new one.

- If you are replacing the alignment assembly, go to step A.
- If you are only adjusting the reference adjustment screw, go to step B.

### Step A

Print a copy of the Quick Test Page and check the margin adjustments printed on the test page. These settings should be within the range specified in **“Registration” on page 3-67**.

Do the reference adjustment if you are sure the margins are set correctly.

1. Loosen the locknut on the inside rear of the alignment assembly.
2. Remove the two screws holding the alignment assembly to the left side frame.
3. Back the reference adjustment screw out far enough to allow the alignment assembly to be removed from the printer. It is not necessary to completely remove the screw.

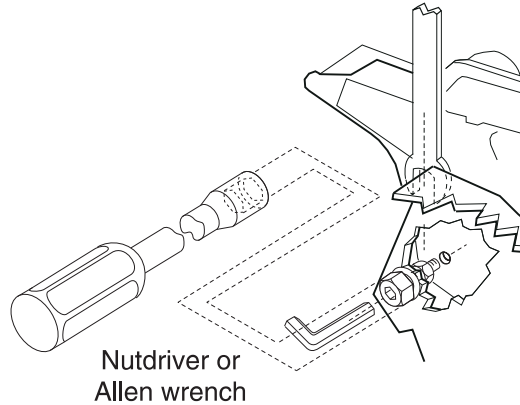

4. Install the new alignment assembly. Turn the reference screw clockwise with a 7 mm nut driver or M3 Allen wrench until it touches the back of the reference plate, and tighten the nut with a 5.5 mm wrench.

The reference adjustment screw can be adjusted without loosening the nut. Turn the screw clockwise a few turns and print a copy of the Quick Test Page as you check the diamonds on the left margin. Continue adjusting the screw as you check the results of each adjustment on a new test page until you obtain the results you want.

## Step B

Print a copy of the Quick Test Page, and check the margin adjustments printed on the test page. These settings should be within the range specified in **“Registration” on page 3-67**. The reference screw can be adjusted without loosening the locknut. Turn the screw a few turns, and print a copy of the Quick Test Page as you check the diamonds on the left margin. Continue adjusting the screw as you check the results of each adjustment on a new test page until you obtain the results you want.

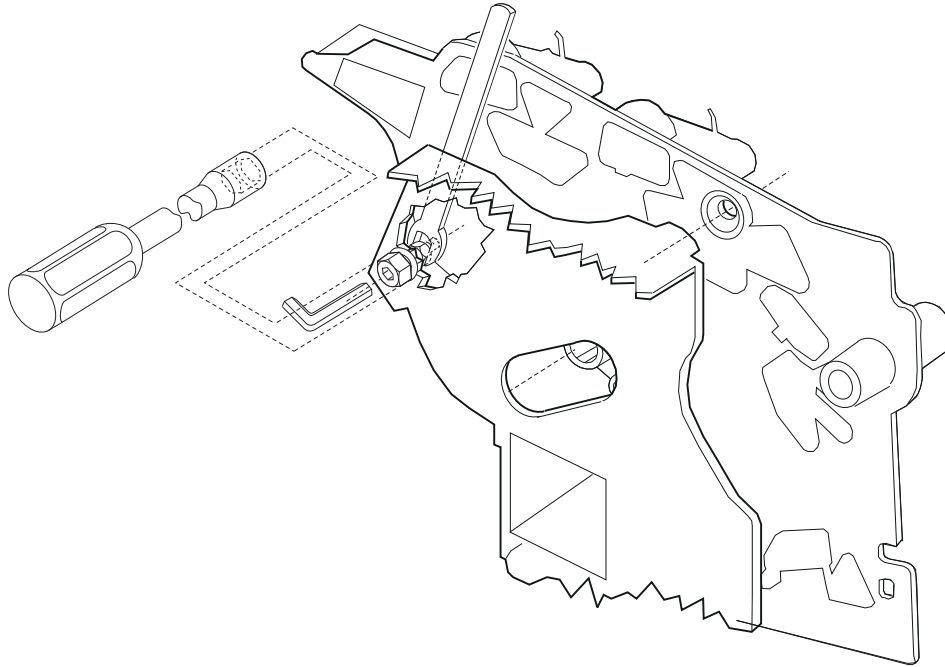

## Fuser solenoid adjustment

Perform the fuser solenoid adjustment whenever you replace the fuser solenoid. Adjust the fuser solenoid while installed in the printer. Adjust the screw on the eccentric mounted on the solenoid housing to provide an air gap between the rear of the solenoid stator and the solenoid armature. The solenoid air gap for all models is  $4.5 \text{ mm} \pm 0.1 \text{ mm}$ .

## Gap adjustment

The gap adjustment allows you to increase the minimum gap between sheets of paper as they are fed through the printer. This adjustment reduces the printer overall performance, such as pages per minute, but can help in reducing the amount of curl of some printed media, thus improving media stacking in the output bin.

1. Enter the Diagnostic Mode.
2. Select **Ep Setup** from the Diagnostic Menu.
3. Select **Gap Adjust**.
4. The range of the GAP adjustment is 0 to 255. Adjust the gap setting by using  to select the value. If GAP=0 displays, it indicates a factory setting to minimum gap. Select a value and run several copies of the media that displays a curl problem. It may take several tries before improvement is noticed.

**Note:** This setting has no effect when duplexing.

---

## Removals

**Replacement note: To replace a removed part, reverse the order of removal unless noted otherwise.**

## Access door removal (T650, T652, T654)

1. Open the access door.
2. Gently detach the two hinges (A) of the access door from the machine.

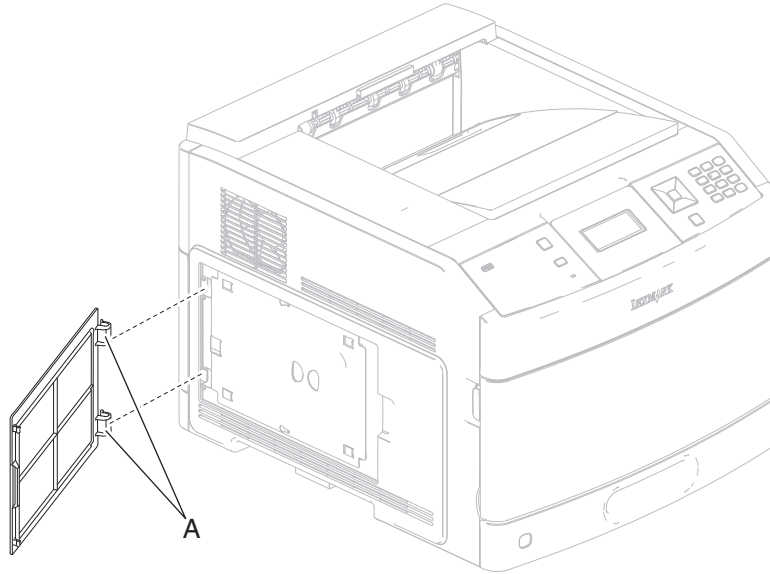

3. Remove the access door.

## Alignment assembly removal (T650, T652, T654)

**WARNING:** When replacing the alignment assembly, ensure that the media skew is properly adjusted using the adjuster screw (C), or jamming will occur. Go to **“Alignment assembly adjustment”** on page 4-4.

1. Remove the side cover, left. Go to **“MPF cam gear removal (T650, T652, T654)”** on page 4-37 or **“Side cover, left removal (T652 and T654)”** on page 4-66.
2. Remove the six screws (A) securing the metal cover to the machine.

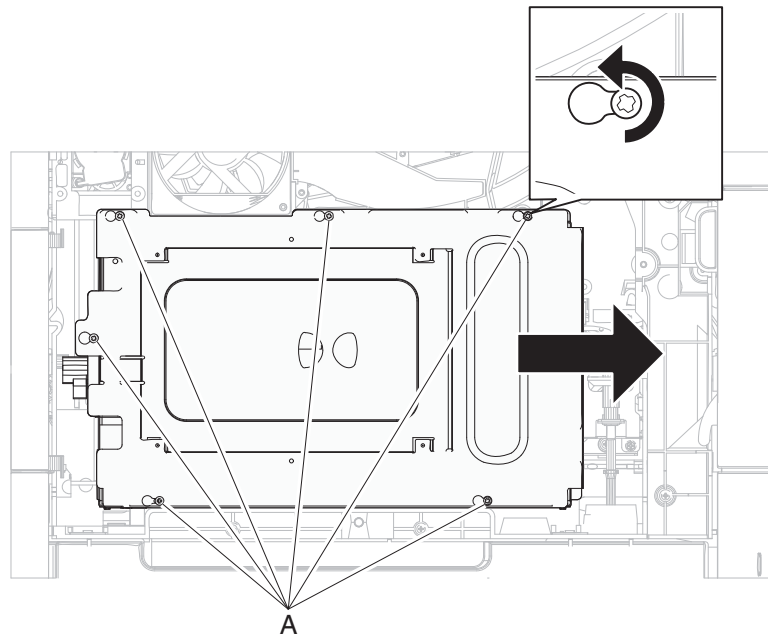

3. Remove the metal cover.
4. Remove the inner deflector. Go to **“Inner deflector removal (T650, T652, T654)”** on page 4-25.

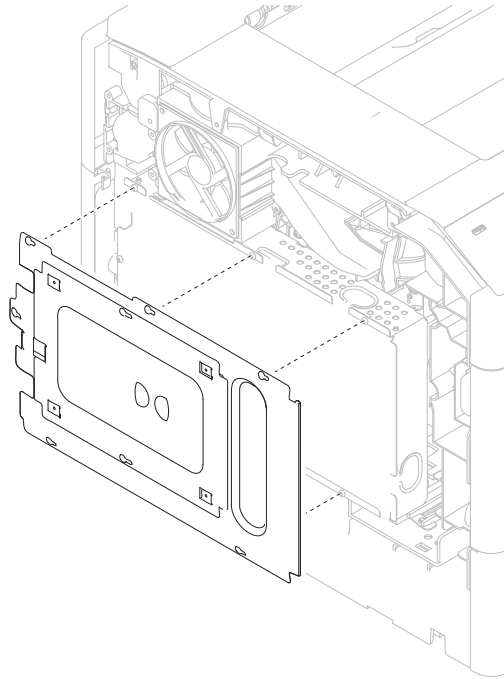

5. Remove the MPF pick solenoid assembly. Go to **“MPF pick solenoid assembly removal (T650, T652, T654)”** on page 4-39.
6. Remove the two screws (B) securing the alignment assembly to the machine.

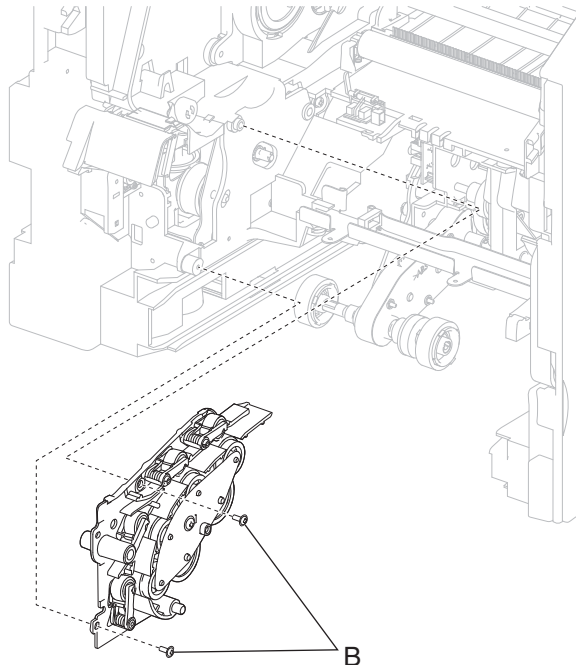

**Note:** The adjuster screw (C) requires a hex wrench to loosen and tighten.

**Note:** The adjuster screw (C) can be accessed through the hole (D) in the system card.

7. Completely loosen the adjuster screw (C) securing the alignment assembly to the machine.

8. Remove the alignment assembly.

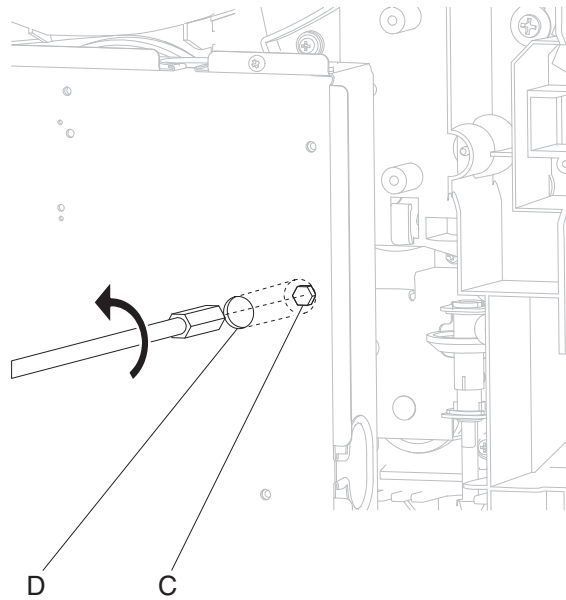

**Replacement Warning:** When replacing the alignment assembly, ensure that the media skew is properly adjusted using the adjuster screw (C) or jamming will occur. Go to **“Alignment assembly adjustment” on page 4-4.**



## Connection access cover, rear removal (T650, T652, T654)

1. Gently detach the two hinges (A) of the connection access cover, rear from the machine.

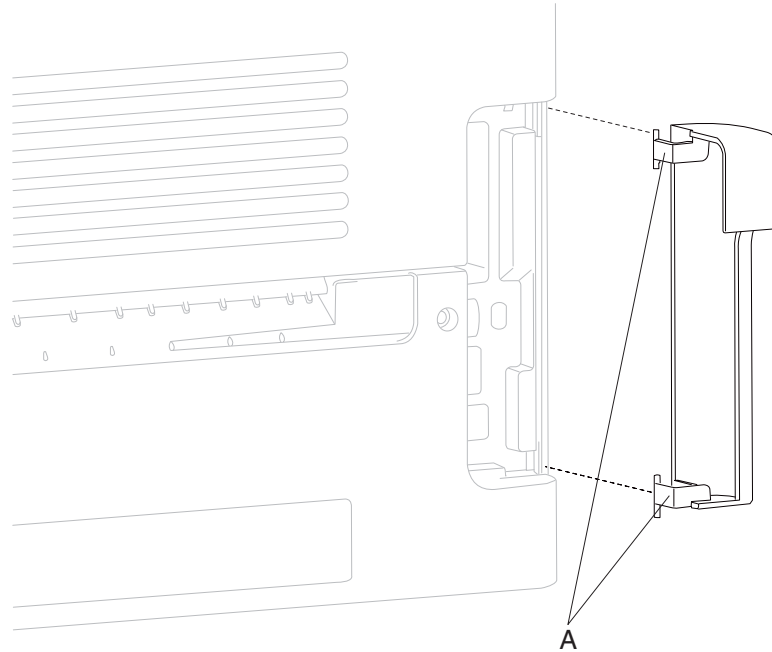

2. Remove the connection access cover, rear.

## Connection bezel assembly, rear removal (T650)

1. Remove the side cover, left. Go to **“MPF cam gear removal (T650, T652, T654)”** on page 4-37.
2. Remove the cover assembly, rear lower. Go to **“Cover assembly, rear lower removal (T650)”** on page 4-13.
3. Release the two hooks (A) securing the connection bezel assembly, rear to the machine.

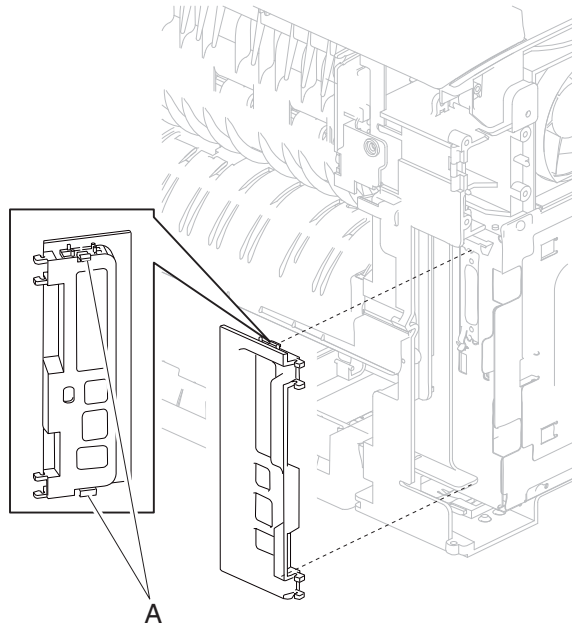

4. Remove the connection bezel assembly, rear.

## Connection bezel assembly, rear removal (T652, T654)

1. Remove the side cover, left. Go to **“Side cover, left removal (T652 and T654)”** on page 4-66.
2. Remove the cover assembly, rear lower. Go to **“Cover assembly, rear lower (T652, T654)”** on page 4-13.
3. Release the two hooks (A) securing the connection bezel assembly, rear to the machine.

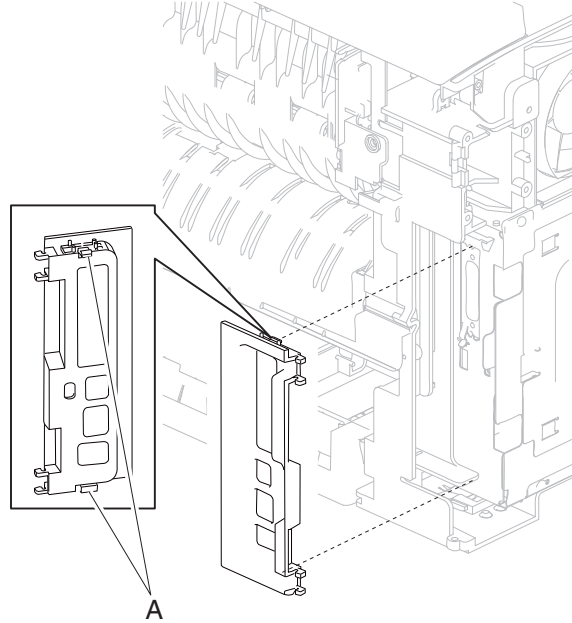

4. Remove the connection bezel assembly, rear.

## Cover assembly, rear lower removal (T650)

1. Remove the fuser access door assembly. Go to **“HVPS card assembly removal (T650, T652, T654)”** on **page 4-24**.
2. Open the rear lower door.
3. Remove the three screws (A) securing the cover assembly, rear lower to the machine.

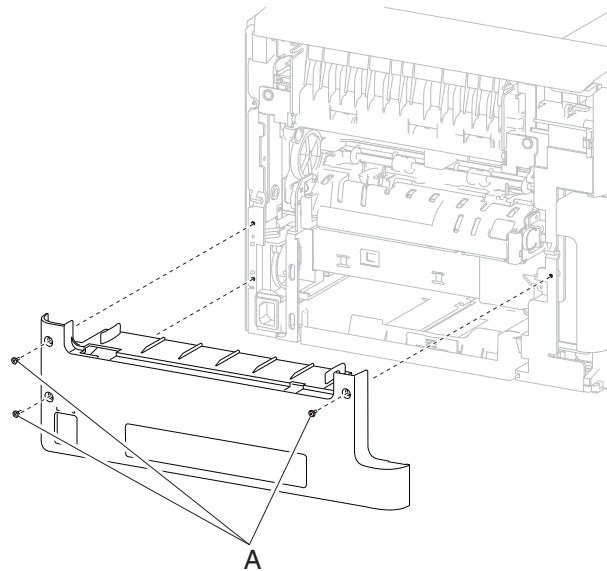

4. Remove the cover assembly, rear lower.

## Cover assembly, rear lower (T652, T654)

1. Open the rear lower door.
2. Remove the four screws (A) securing the cover assembly, rear lower to the machine.

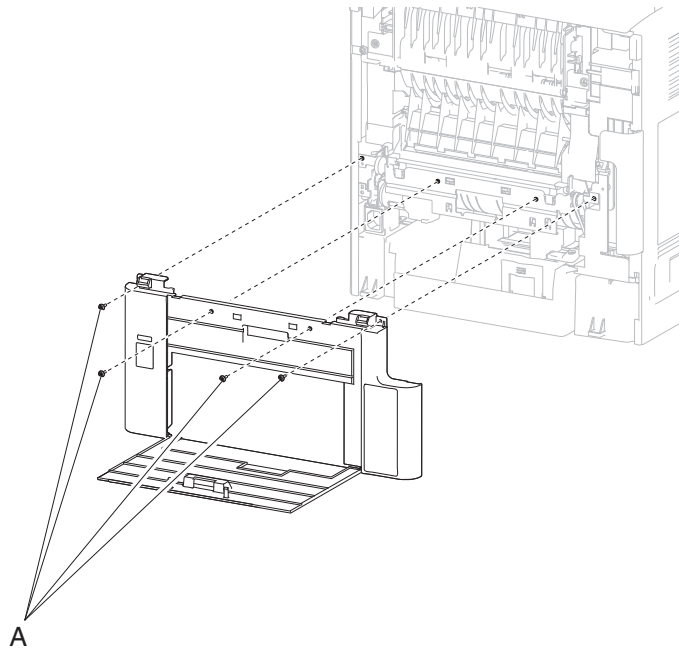

3. Remove the cover assembly, rear lower.

## Charge roll assembly removal (T650, T652, T654)

**WARNING:** When removing the charge roll assembly, avoid touching the charge roll surface.

1. Open the MPF door assembly.
2. Open the operator panel front cover assembly.
3. Detach the left side of the charge roll assembly from the machine.

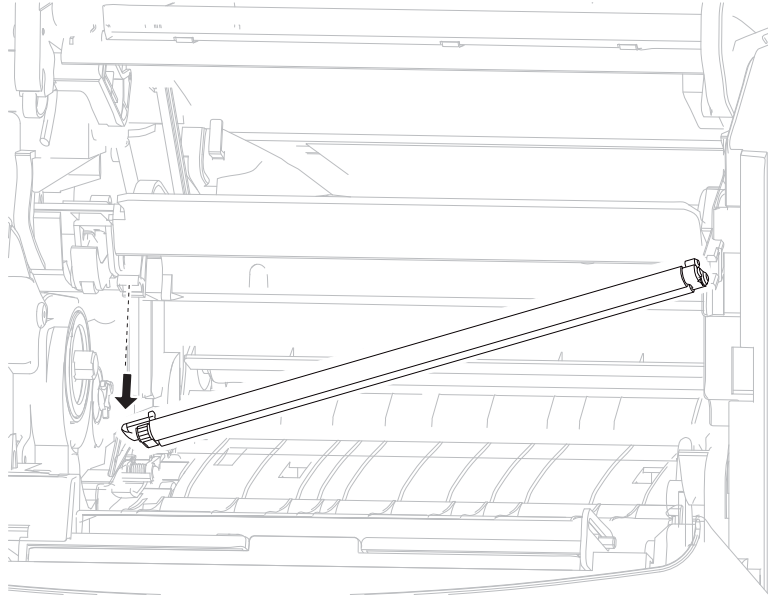

4. Detach the right side of the charge roll assembly from the machine.

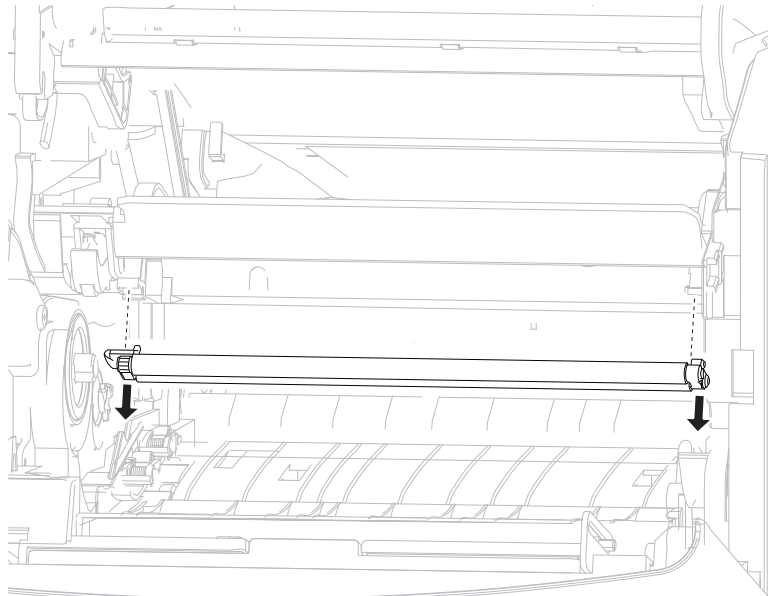

5. Remove the charge roll assembly.

**Replacement Warning:** When replacing the charge roll assembly, avoid touching the charge roll surface.

## Door assembly, rear removal (T650, T652, T654)

1. Pull the door assembly, rear away from the machine.
2. Twist the door strap left or right until vertical, and pull the strap out of the slot.
3. Position the door assembly, rear at a 45° angle as shown in the picture.
4. Remove the door assembly, rear.

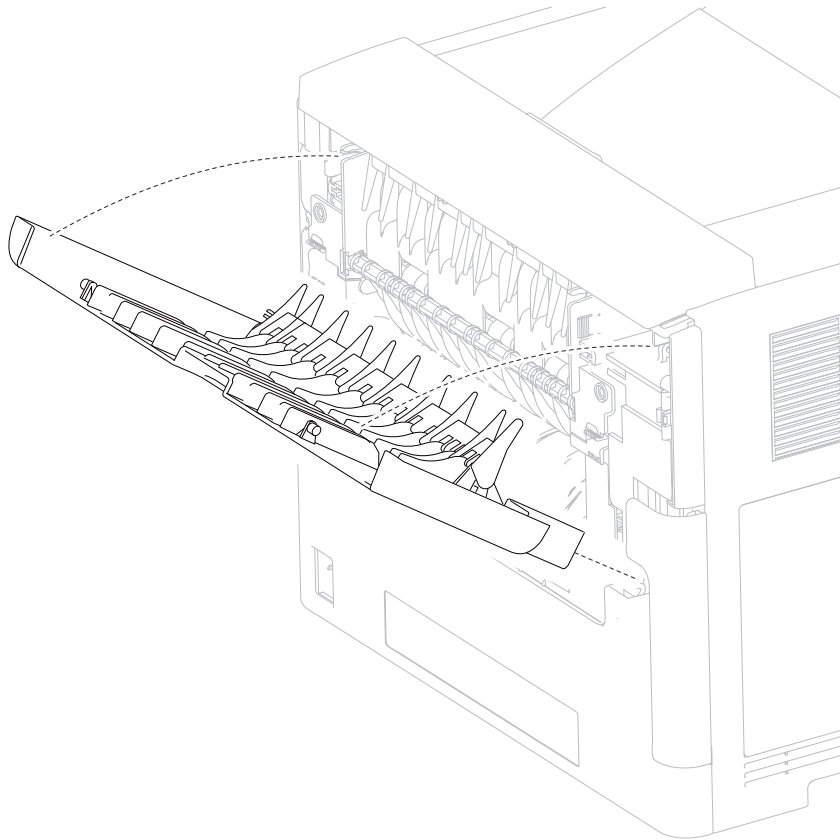

## Duplex guide assembly, rear removal (T652, T654)

1. Remove the cover assembly, rear lower. Go to **“Cover assembly, rear lower (T652, T654)” on page 4-13.**
2. Remove the media tray.
3. Gently place the printer on its left or right side.
4. Remove the two screws (A) securing the two retainers (B) to the machine.
5. Remove the two retainers (B).

- Detach the rear duplex guide spring (C).

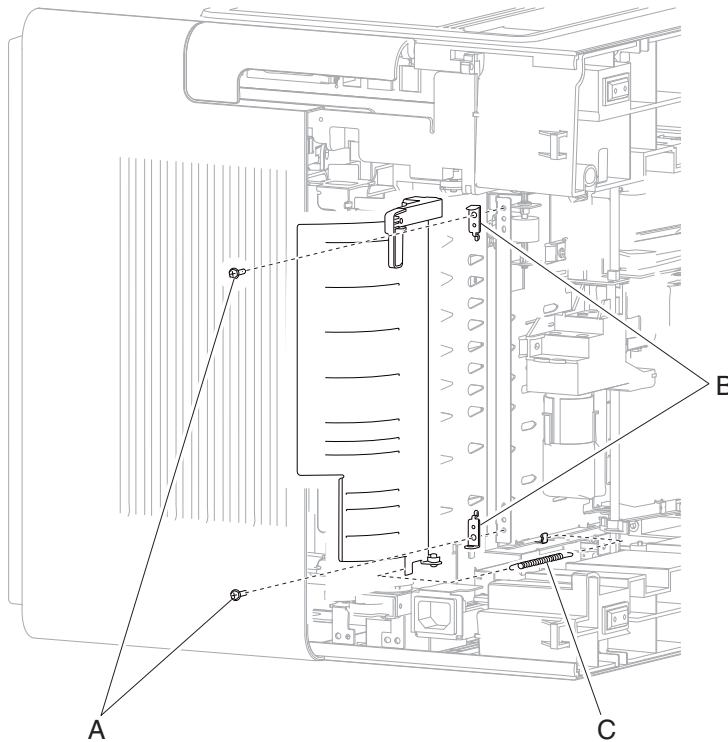

- Remove the duplex guide assembly, rear.
- Remove the screw (D) securing the rear duplex guide handle to the assembly.

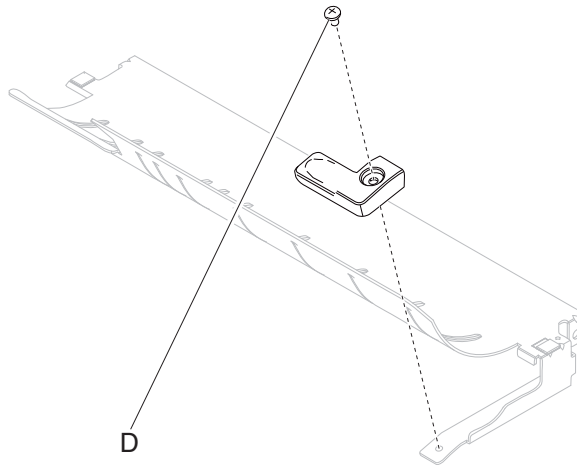

- Remove the duplex guide assembly, rear.

## Duplex assembly removal (T652, T654)

**Note:** When removing the duplex drive motor assembly, it does not need to be completely removed from the machine. It may be allowed to gently hang out of the way by the harness.

- Remove the duplex drive motor assembly. Go to **“Duplex drive motor assembly removal (T652, T654)” on page 4-19.**
- Remove the pick arm assembly. Go to **“Operator panel door assembly removal (models X651, X652, X654, and X656)” on page 4-49.**
- Remove the four screws (A) securing the duplex assembly to the machine.

4. Remove the harnesses (B) from the clamp.
5. Disconnect the connection (C) from the duplex assembly.

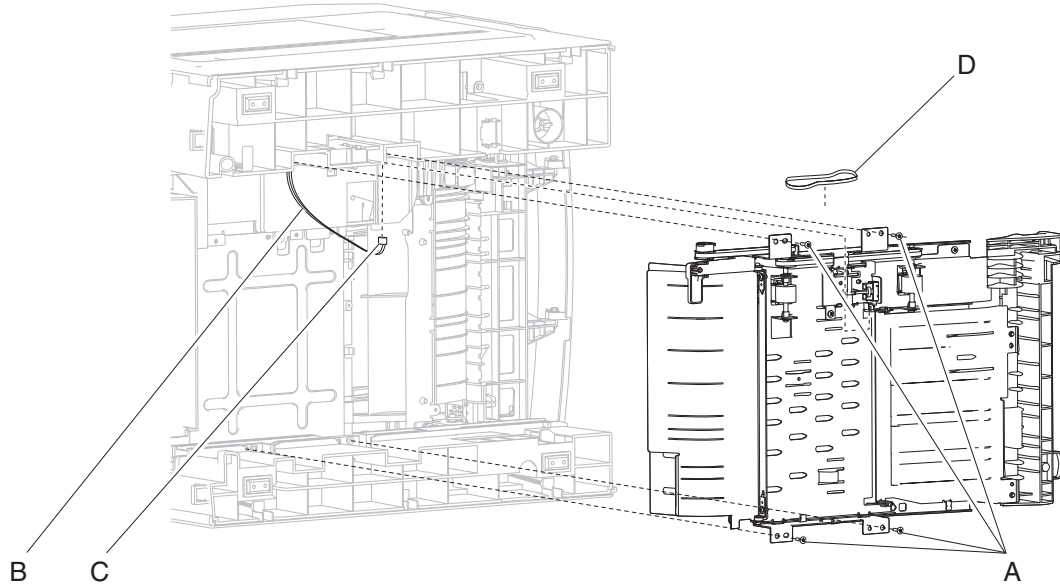

**Note:** When removing the duplex assembly, the lower duplex drive belt (D) will become detached.

6. Remove the duplex assembly.

**Replacement Warning:** When replacing the duplex assembly, ensure that the lower duplex drive belt (D) is properly reattached.

## Duplex cooling fan removal (T652, T654)

1. Remove the side cover, right. Go to **“Side cover, right removal (T652, T654)”** on page 4-68.
2. Remove the screw (A) securing the duplex cooling fan to the machine.
3. Disconnect the connector (B) from the duplex cooling fan.

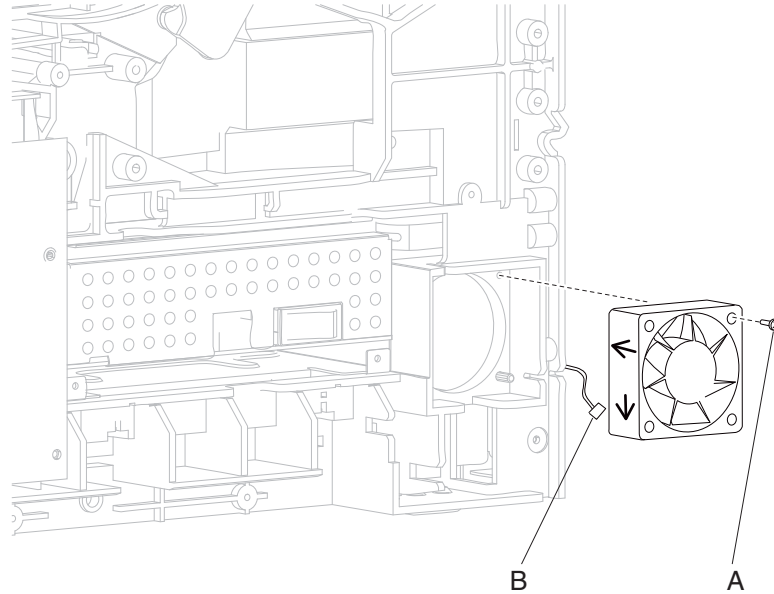

4. Remove the duplex cooling fan.

**Replacement Warning:** When replacing the duplex cooling fan, ensure that it is installed as shown in the picture.



## Duplex drive motor assembly removal (T652, T654)

1. Remove the fuser access door. Go to **“HVPS card assembly removal (T650, T652, T654)”** on page 4-24.
2. Remove the cover assembly, rear lower. Go to **“Cover assembly, rear lower (T652, T654)”** on page 4-13.
3. Remove the three screws (A) securing the duplex drive motor assembly to the machine.

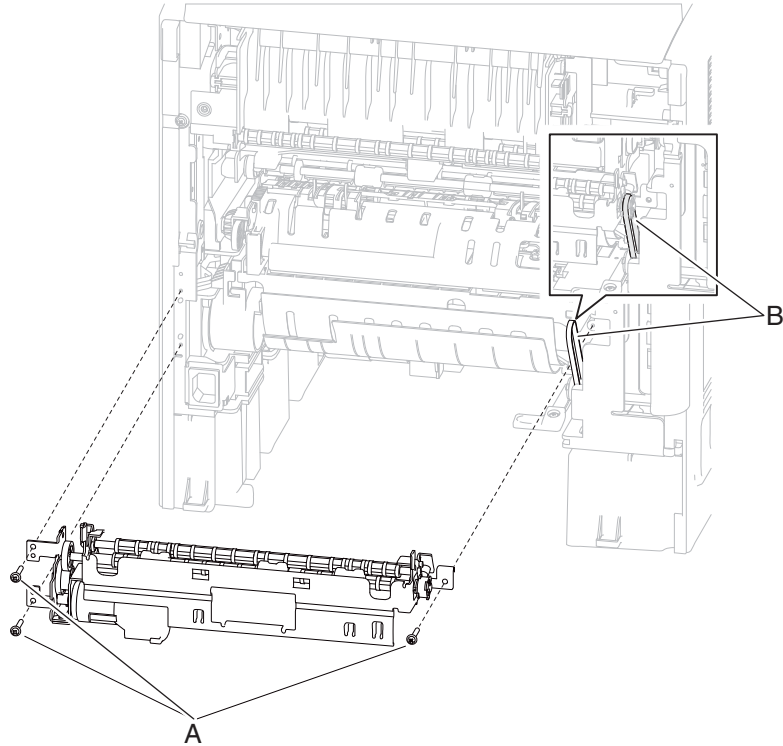

**Note:** When removing the duplex drive motor assembly, the upper duplex drive belt (B) will become detached.

4. Remove the band (C) from the duplex drive motor assembly.

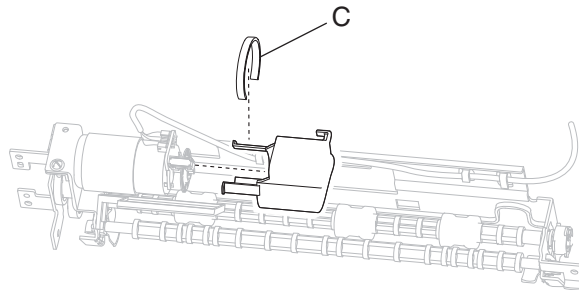

5. Remove the cover from the duplex drive motor assembly.
6. Disconnect the connection (D) to the duplex drive motor assembly.

7. Remove the harness (E) from the duplex drive motor assembly.

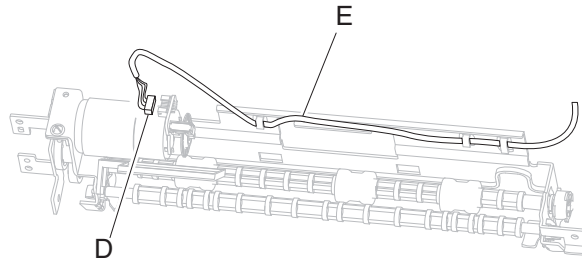

**Replacement Warning:** When replacing the duplex drive motor assembly, ensure that all harnesses are properly re-routed.

**Replacement Note:** Ensure the belt is replaced properly.

### Duplex input sensor assembly removal (T652, T654)

1. Remove the media tray.
2. Gently place the printer on its left or right side.
3. Disconnect the connection (A) from the duplex input sensor assembly.
4. Remove the two screws (B) securing the duplex input sensor assembly to the machine.

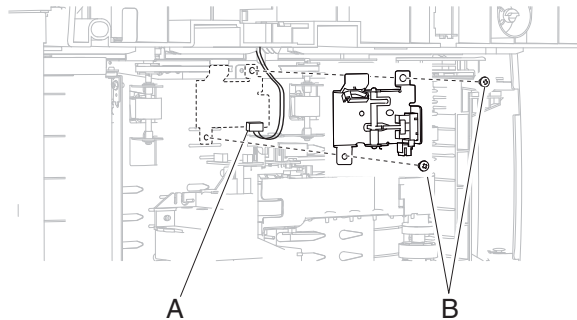

5. Remove the duplex input sensor assembly.

## Duplex guide assembly, front removal (T652, T654)

1. Remove the media tray.
2. Gently place the printer on its left or right side.
3. Detach the front left duplex guide spring (A) from the duplex guide assembly, front.
4. Detach the front right duplex guide spring (B) from the duplex guide assembly, front.

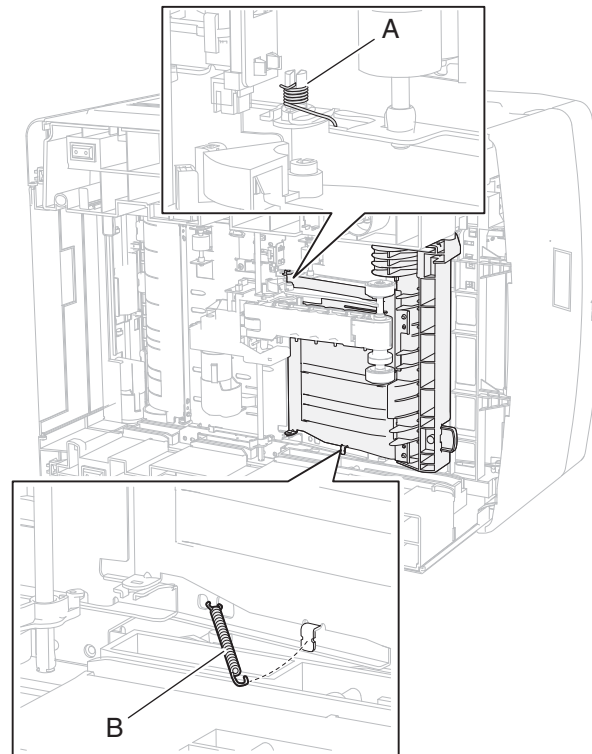

5. Fully open the duplex guide assembly, front 90°, and detach it from the machine.
6. Remove the duplex guide assembly, front.

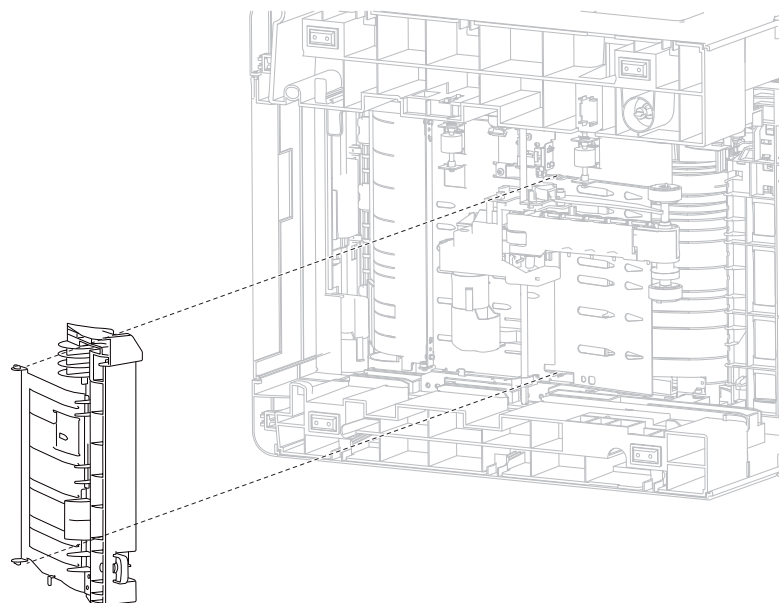

## Fuser access door assembly removal (T650, T652, T654)

1. Remove the door assembly, rear. Go to **“Door assembly, rear removal (T650, T652, T654)”** on **page 4-15**.
2. Press the two tabs (A) on the fuser access door assembly, and detach it from the machine.

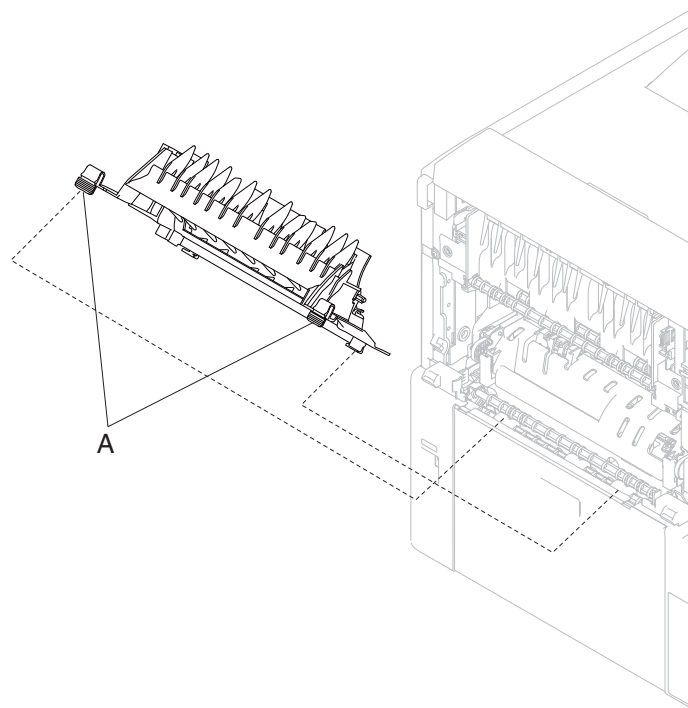
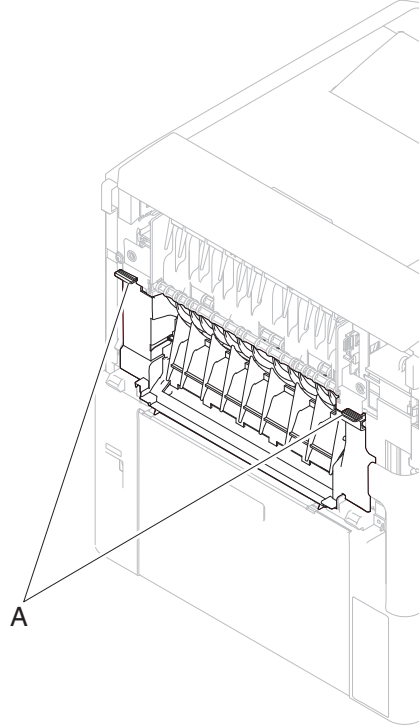

3. Swing the fuser access door assembly away from the machine.
4. Unsnap the fuser access door assembly from the machine.
5. Remove the fuser access door assembly.

### Fuser drive release linkage removal (T650, T652, T654)

1. Remove the system card assembly. Go to **“System card assembly removal (T650, T652, T654, T656)” on page 4-76.**
2. Gently unsnap the upper end of the fuser drive release linkage from the machine.
3. Rotate the fuser drive release linkage 90° to release the lower end of the fuser drive release linkage from the machine.
4. Remove the fuser drive release linkage.

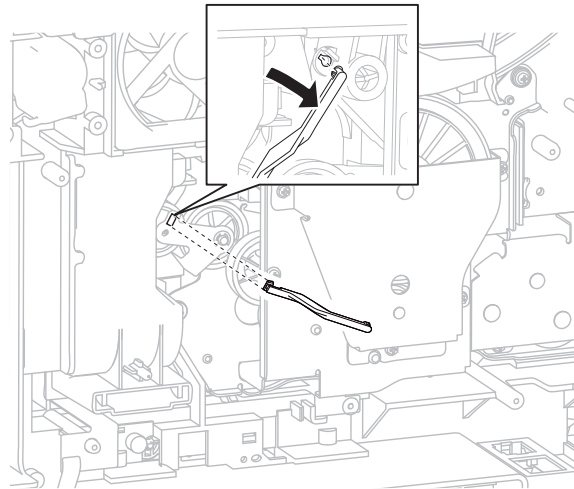

### Fuser unit assembly removal (T650, T652, T654)

1. Remove the fuser wiper cover assembly. Go to **“Fuser wiper cover assembly removal (T650, T652, T654)” on page 4-24.**
2. Remove the door assembly, rear. Go to **“Door assembly, rear removal (T650, T652, T654)” on page 4-15.**
3. Open the fuser access door.
4. Press the two buttons (A) on the fuser unit assembly to release it from the machine.

5. While pressing the two buttons (A), pull the fuser unit assembly from the machine.

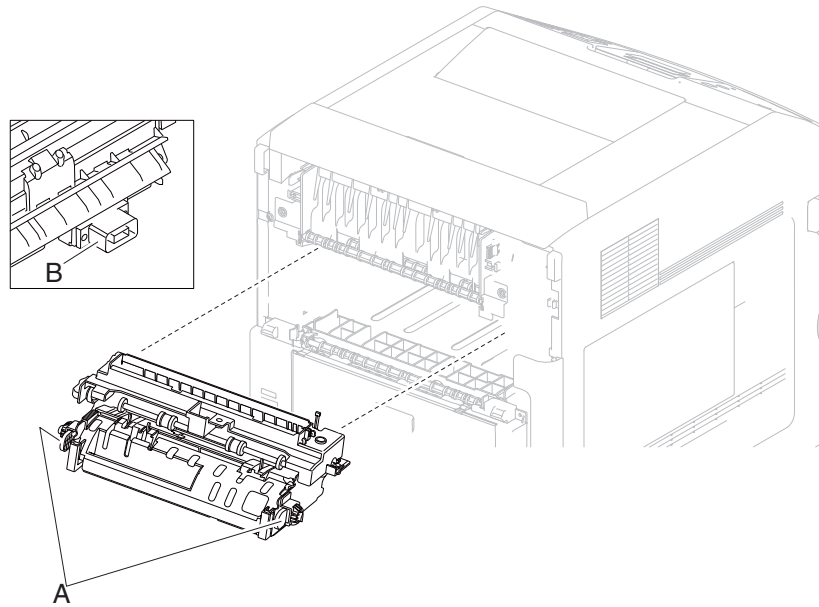

**Replacement Warning:** When replacing the fuser unit assembly, ensure that the electrical connection (B) and the two buttons (A) are properly secured.

### Fuser wiper cover assembly removal (T650, T652, T654)

1. Press the button (A) securing the fuser wiper cover assembly to the machine.

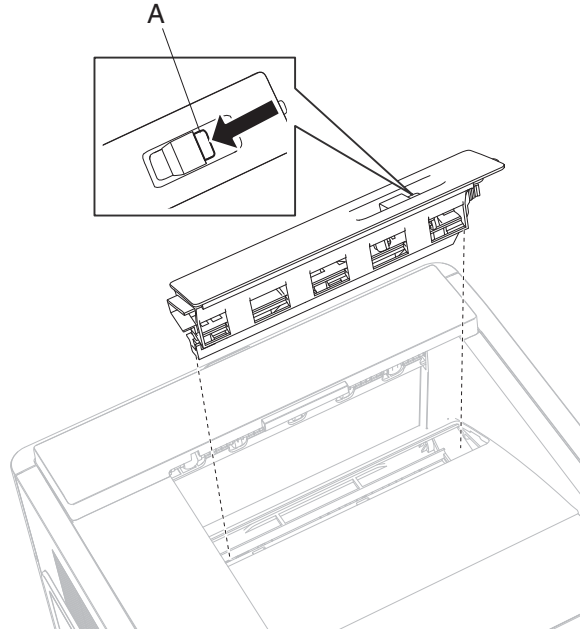

2. Remove the fuser wiper cover assembly.

### HVPS card assembly removal (T650, T652, T654)

1. Remove the side cover, right. Go to **“Side cover, right removal (T650)” on page 4-67** or **“Side cover, right removal (T652, T654)” on page 4-68.**

2. Remove the four screws (A) securing the HVPS card assembly to the machine.
3. Remove the HVPS card assembly.
4. Remove connection (B) and the two high voltage connections (C) from the HVPS card assembly.

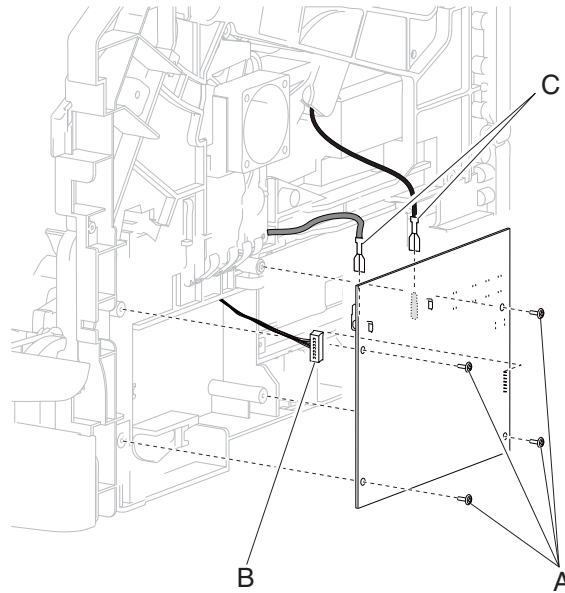

**Replacement Warning:** When replacing the HVPS card assembly, ensure that the two high voltage connections (C) are properly replaced.

### Inner deflector removal (T650, T652, T654)

**Note:** The MPF lift plate assembly can be detached and allowed to hang by the harness. The connection to the MPF lower deflector assembly does not need to be disconnected.

1. Remove the MPF lift plate assembly. Go to **“MPF lift plate assembly removal (T650, T652, T654)” on page 4-37.**

2. Release the two hooks (A) securing the lower portion of the inner deflector to the machine.

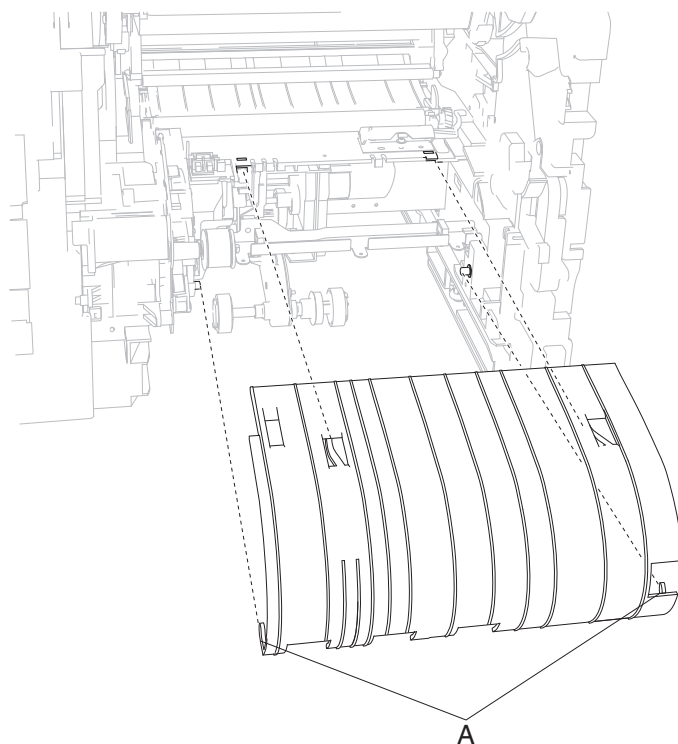

3. Remove the inner deflector.

**Replacement Warning:** When replacing the inner deflector, ensure that it is properly installed, or jamming will occur.



## Laser cover removal (T650, T652, T654)

1. Remove the output cover assembly. Go to **“Output cover assembly removal (T650, T652, T654)” on page 4-54.**
2. Remove the fuser wiper cover assembly. Go to **“Fuser wiper cover assembly removal (T650, T652, T654)” on page 4-24.**
3. Remove the side cover, left. Go to **“MPF cam gear removal (T650, T652, T654)” on page 4-37** or **“Side cover, left removal (T652 and T654)” on page 4-66.**
4. Remove the side cover, right. Go to **“Side cover, right removal (T650)” on page 4-67** or **“Side cover, right removal (T652, T654)” on page 4-68.**
5. Remove the five screws (A) securing the laser cover to the machine.

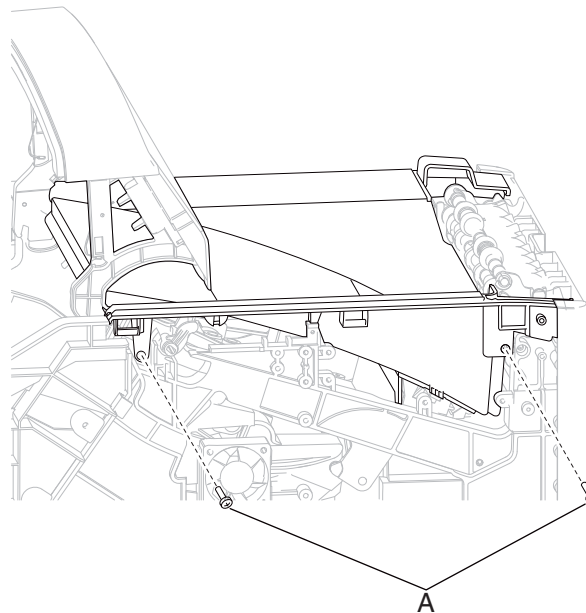
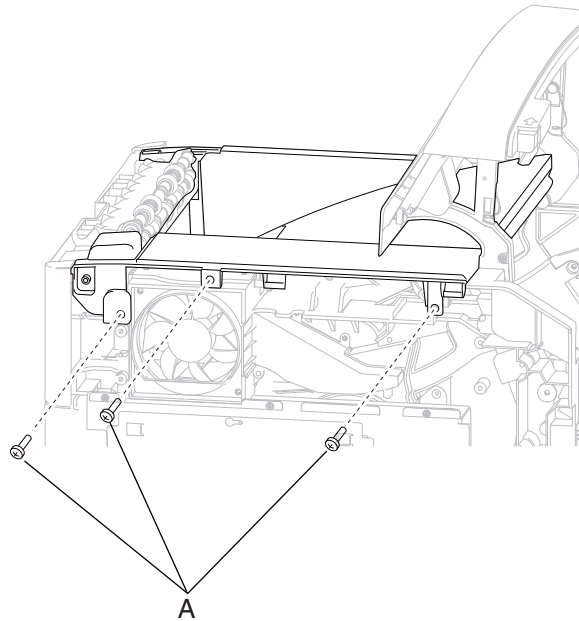

**WARNING:** When removing the laser cover, ensure that the standard bin actuator assembly does not become damaged.

6. Remove the laser cover.

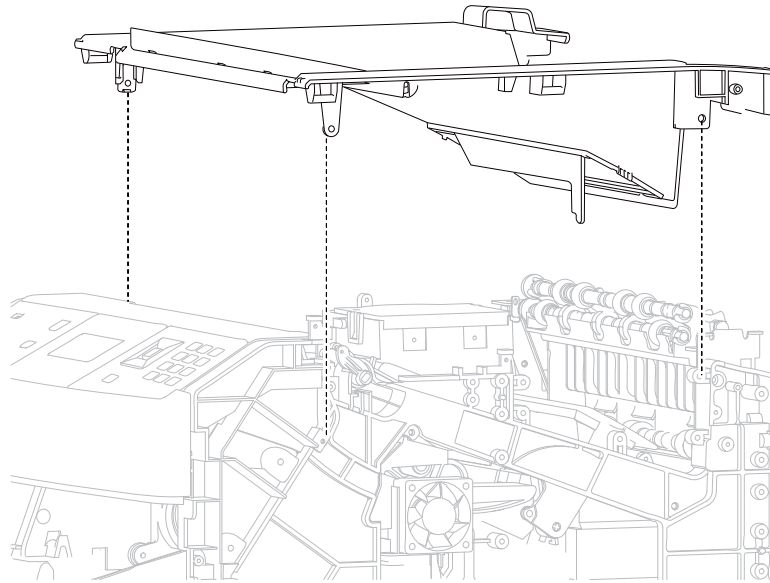

### LCD screen bezel removal (T650, T652, T654)

Gently detach the LCD screen bezel from the operator panel door assembly.

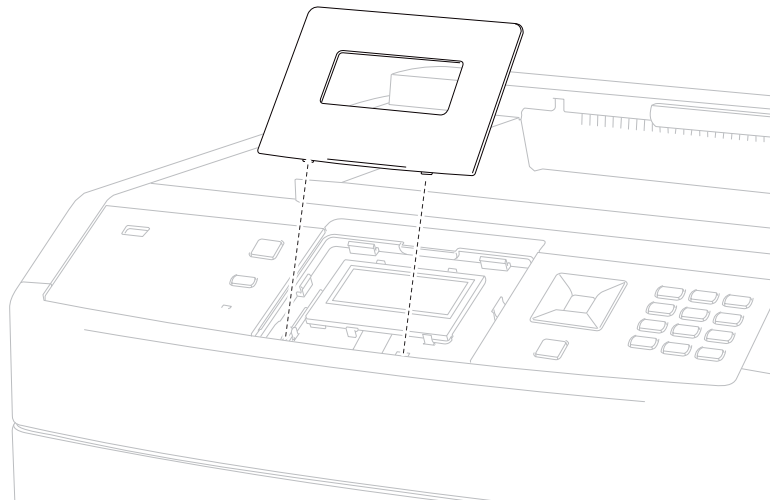

## LVPS card assembly removal (T650)

**WARNING:** When replacing the LVPS card assembly, ensure that the voltage selection switch is set to the proper setting, or damage will occur.

1. Remove the door assembly, rear. Go to **“Door assembly, rear removal (T650, T652, T654)” on page 4-15.**
2. Remove the side cover, right. Go to **“Side cover, right removal (T650)” on page 4-67.**
3. Disconnect the connector (A) from the LVPS card assembly.
4. Remove the two screws (B) from the LVPS card assembly.

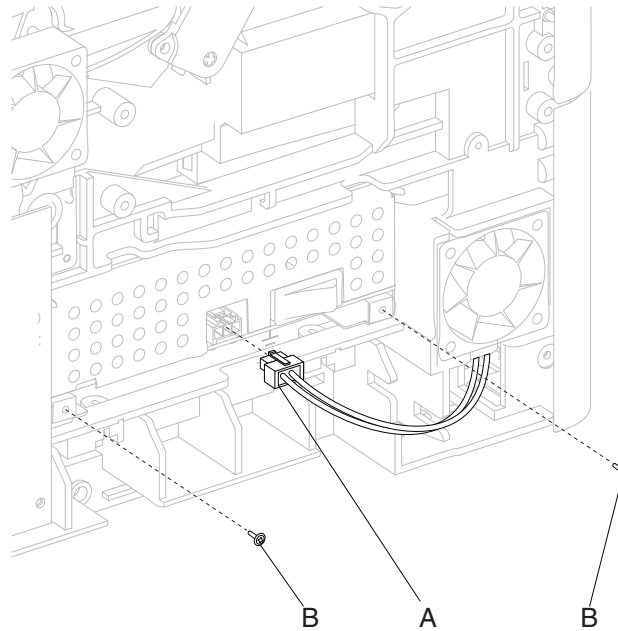

5. Gently pull the LVPS card assembly from the machine.

6. Disconnect the connector (C) from the LVPS card assembly.

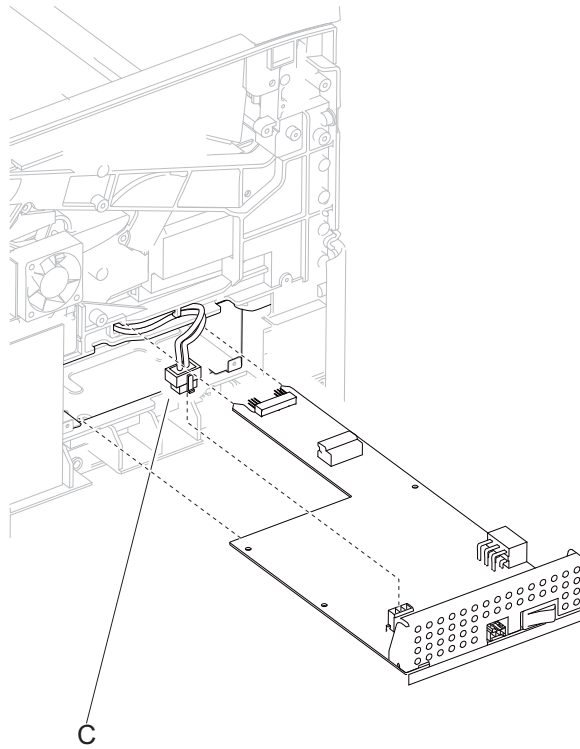

7. Remove the LVPS card assembly.

**Replacement Warning:** When replacing the LVPS card assembly, ensure that all connections are replaced.

**Replacement Warning:** When replacing the LVPS card assembly, ensure that the connector pins (D) properly engage the system card.

**Replacement Warning:** When replacing the LVPS card assembly, ensure that the voltage selection switch (E) is set to the proper setting, or damage will occur.

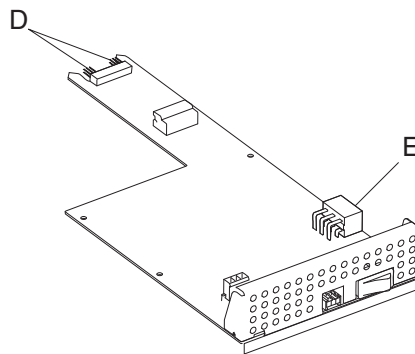

## LVPS card assembly removal (T652, T654)

**WARNING:** When replacing the LVPS card assembly, ensure that the voltage selection switch (E) is set to the proper setting, or damage will occur.

1. Remove the door assembly, rear. Go to **“Door assembly, rear removal (T650, T652, T654)” on page 4-15.**
2. Remove the side cover, right. Go to **“Side cover, right removal (T652, T654)” on page 4-68.**
3. Disconnect the connector (A) from the LVPS card assembly.
4. Remove the two screws (B) from the LVPS card assembly.

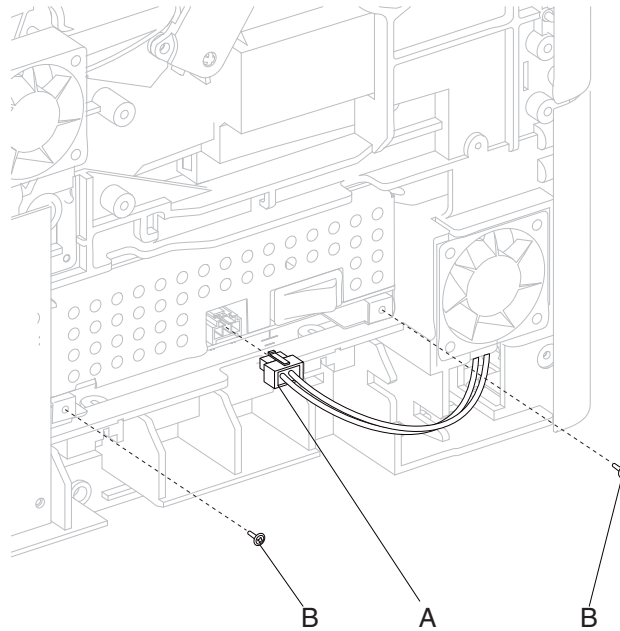

5. Gently pull the LVPS card assembly from the machine.

- Disconnect the connector (C) from the LVPS card assembly.

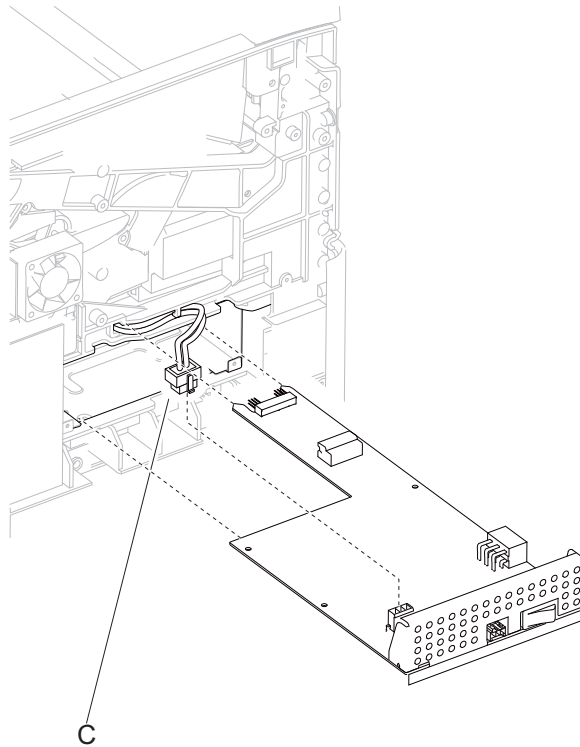

- Remove the LVPS card assembly.

**Replacement Warning:** When replacing the LVPS card assembly, ensure that all connections are replaced.

**Replacement Warning:** When replacing the LVPS card assembly, ensure that the connector pins (D) properly engage the system card.

**Replacement Warning:** When replacing the LVPS card assembly, ensure that the voltage selection switch (E) is set to the proper setting, or damage will occur.

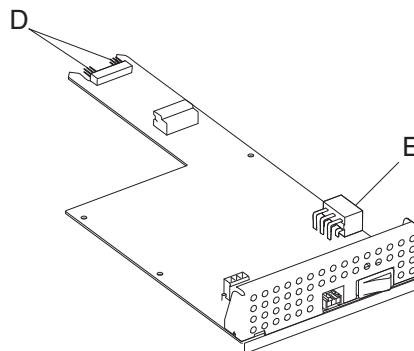

## Main cooling fan removal (T650, T652, T654)

- Remove the side cover, left assembly. Go to **“MPF cam gear removal (T650, T652, T654)”** on page 4-37 or **“Side cover, left removal (T652 and T654)”** on page 4-66.

2. Remove the six screws (A) securing the metal shield to the machine.

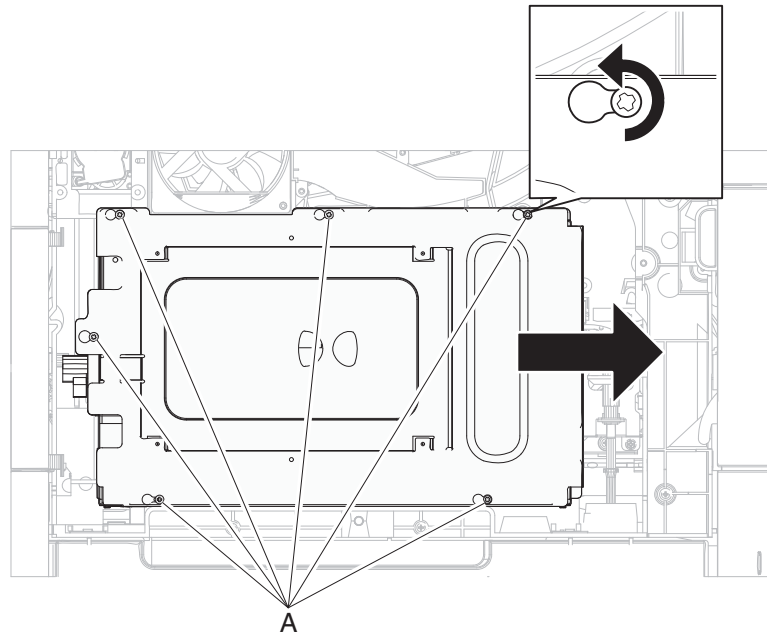

3. Move the metal shield in the direction of the arrow.
4. Remove the metal shield.

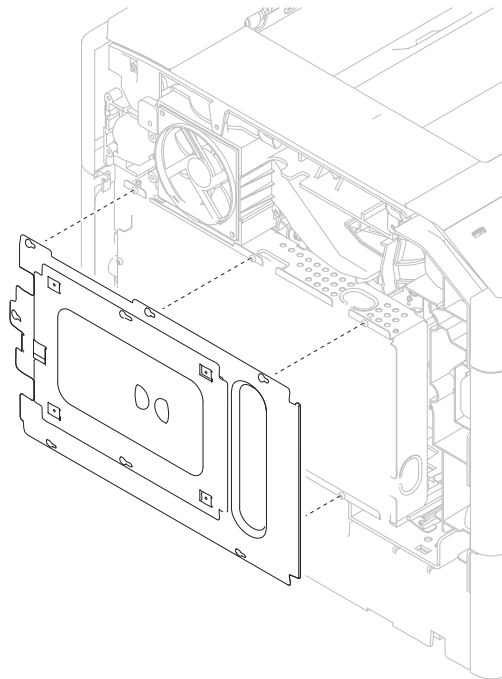

5. Remove the two screws (B) securing the fuser cooling fan to the machine.
6. Remove the fuser cooling fan.

7. Remove the fuser cooling fan connection (C).

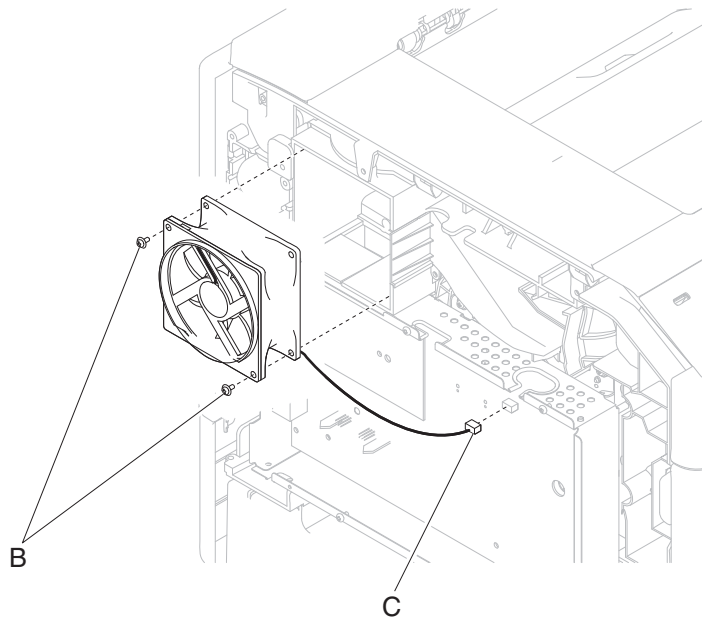

### Main drive motor assembly removal (T650, T652, T654)

1. Remove the system card assembly. Go to **“System card assembly removal (T650, T652, T654, T656)” on page 4-76.**
2. Remove the fuser drive release linkage. Go to **“Fuser drive release linkage removal (T650, T652, T654)” on page 4-23.**
3. Close the operator panel door assembly.
4. Remove the four screws (A) securing the main drive motor assembly to the machine.
5. Gently remove the main drive motor assembly.



- Disconnect the connection (B) from the main drive motor assembly.

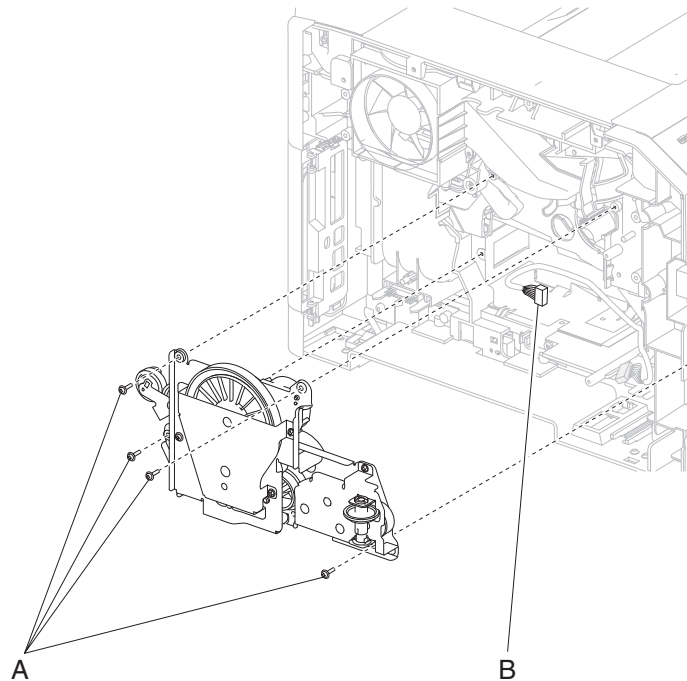

**Replacement Warning:** Ensure that all electrical connections are properly replaced.

**Replacement Warning:** When replacing the main drive motor assembly, ensure that the operator panel door assembly is in the closed position or the main drive motor assembly will not align properly and damage will occur.

**Replacement Warning:** When replacing the main drive motor assembly, ensure that all gears and drive shafts are properly aligned, or damage will occur.

### Media out actuator removal (T650, T652, T654)

- Remove the pick arm assembly. Go to **“Operator panel door assembly removal (models X651, X652, X654, and X656)”** on page 4-49.
- Release the hook (A) securing the media out actuator to the unit.

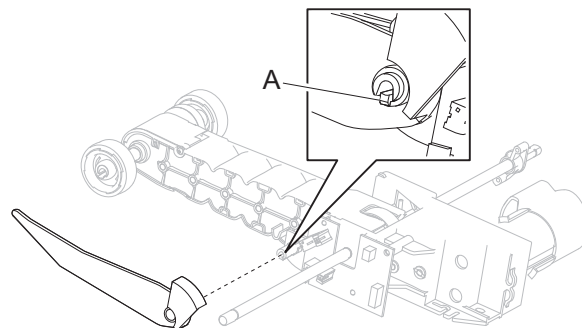

- Remove the media out actuator.

## Media support removal (T650, T652, T654)

1. Gently detach the two bosses (A) of the media support from the machine.

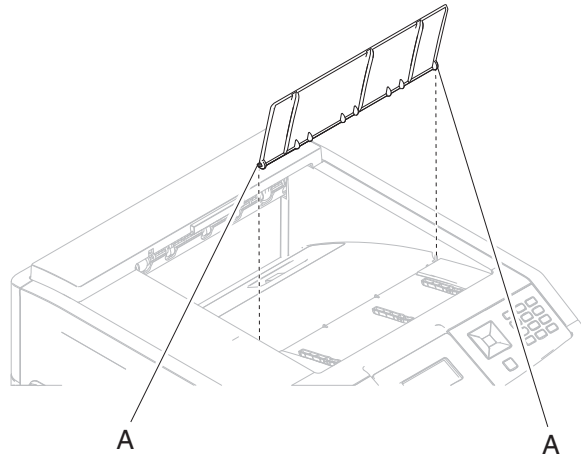

2. Remove the media support.

## Media turn guide removal (T650, T652, T654)

1. Remove the MPF tray door assembly. Go to **“MPF tray door assembly removal (T650, T652, T654)”** on **page 4-41**.
2. Gently bend the left side of the media turn guide to release the hook (A) as shown in the picture.

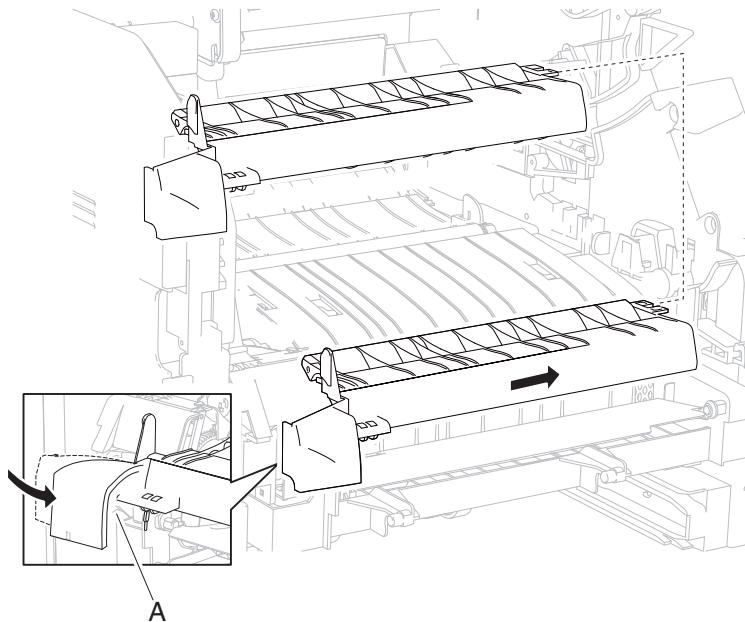

3. While gently bending the media turn guide, move the media turn guide in the direction of the arrow.
4. Remove the media turn guide.

**Replacement Warning:** When replacing the media turn guide, ensure that it is properly installed, or jamming will occur.

## MPF cam gear removal (T650, T652, T654)

1. Remove the alignment assembly. Go to **“Output cover assembly removal (T650, T652, T654)”** on **page 4-54**.
2. Release the hook (A) securing the gear to the unit.

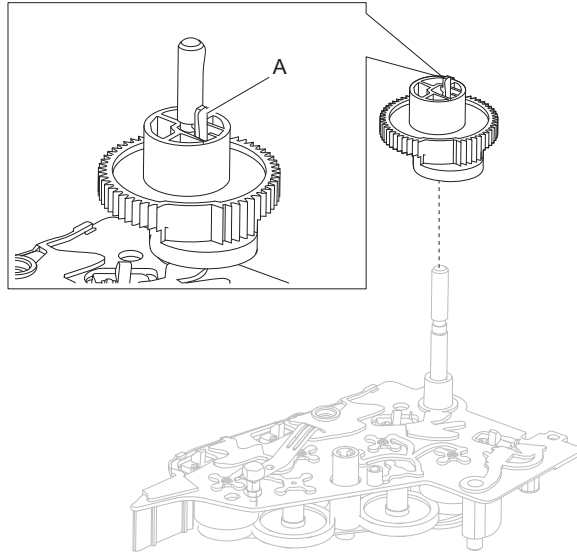

3. Remove the MPF cam gear.

## MPF lift plate assembly removal (T650, T652, T654)

1. Remove the media turn guide. Go to **“Media turn guide removal (T650, T652, T654)”** on **page 4-36**.
2. Remove the four screws (A) securing the MPF lift plate assembly to the machine.
3. Gently detach the MPF lift plate assembly.
4. Disconnect the connector (B) from the MPF lower deflector assembly.

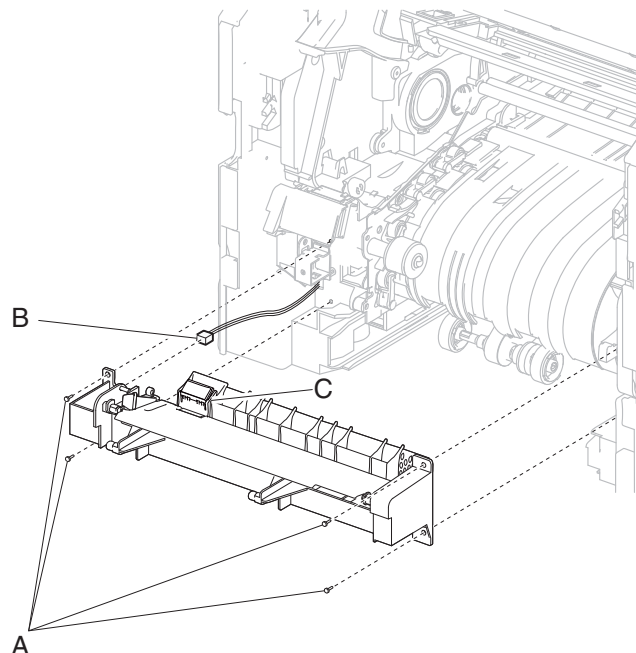

- Remove the MPF lift plate assembly.

**Replacement Warning:** When replacing the MPF lift plate assembly, ensure that the lever (C) is held down when reinstalling the MPF lift plate assembly, or damage will occur.

**Replacement Warning:** When replacing the MPF lift plate assembly, ensure that the MPF pick solenoid assembly does not become damaged.

### MPF media out actuator removal (T650, T652, T654)

- Remove the media turn guide. Go to **“Media turn guide removal (T650, T652, T654)” on page 4-36.**
- Gently unsnap the MPF media out actuator from the machine.

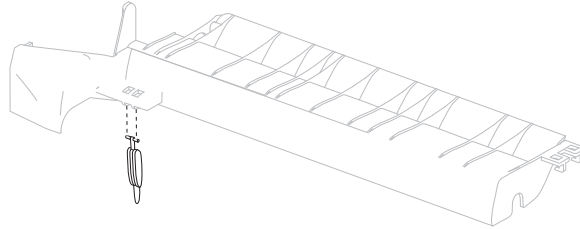

- Remove the media out actuator.

### MPF pick roll assembly removal (T650, T652, T654)

- Remove the media turn guide. Go to **“Media turn guide removal (T650, T652, T654)” on page 4-36.**
- Remove the E-clip (A) securing the MPF print roll assembly to the machine.
- Remove the plastic washer (B).

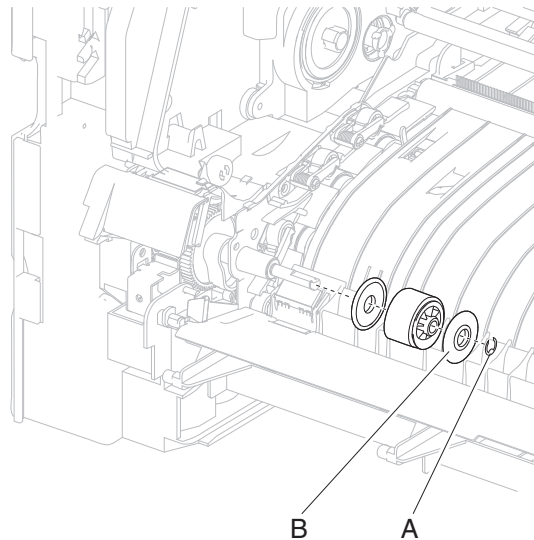

- Remove the MPF pick roll assembly.

**Replacement Warning:** When replacing the MPF pick roll assembly, do not touch the rubber surface.

## MPF pick solenoid assembly removal (T650, T652, T654)

**Note:** The MPF lift plate assembly can be detached and allowed to hang by the harness. The connection does not need to be disconnected.

1. Remove the MPF lift plate assembly. Go to **“MPF lift plate assembly removal (T650, T652, T654)” on page 4-37.**
2. Remove the side cover, left. Go to **“MPF cam gear removal (T650, T652, T654)” on page 4-37** or **“Side cover, left removal (T652 and T654)” on page 4-66.**
3. Remove the six screws (A) securing the metal cover to the machine.

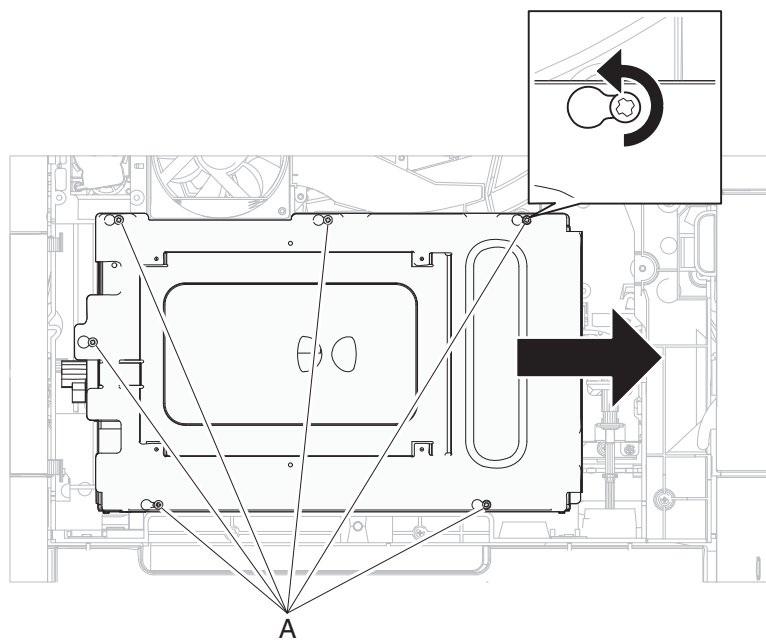

4. Remove the metal cover.

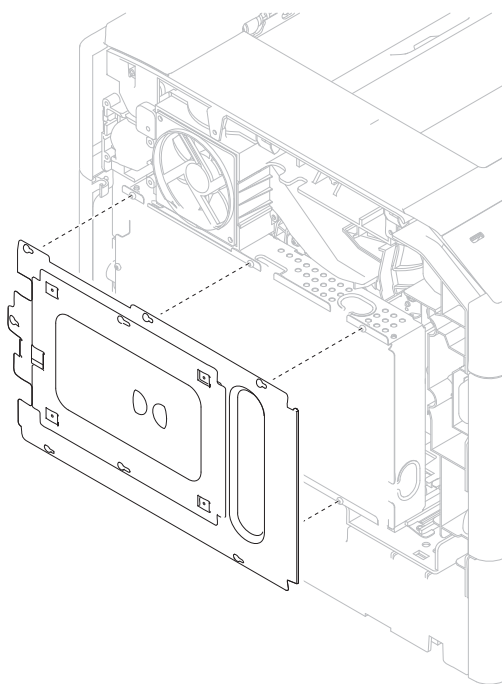

5. Remove the screw (B) securing the MPF pick solenoid assembly to the machine.

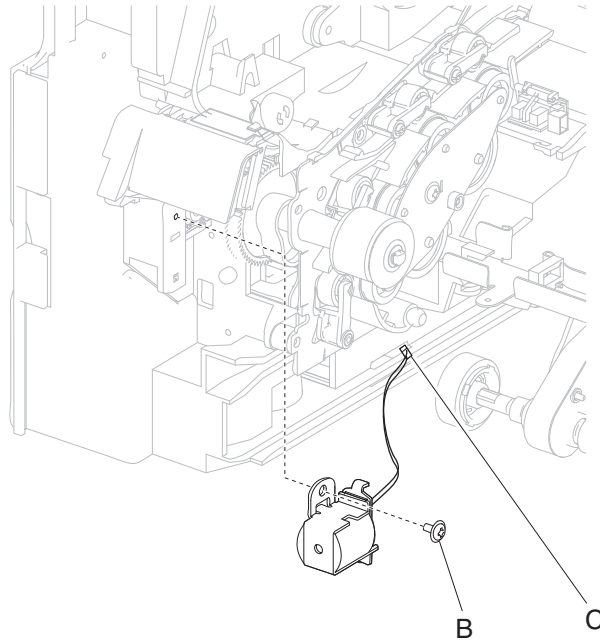

6. Remove the MPF pick solenoid assembly.
7. Disconnect the connection (C) from the MPF pick solenoid assembly.

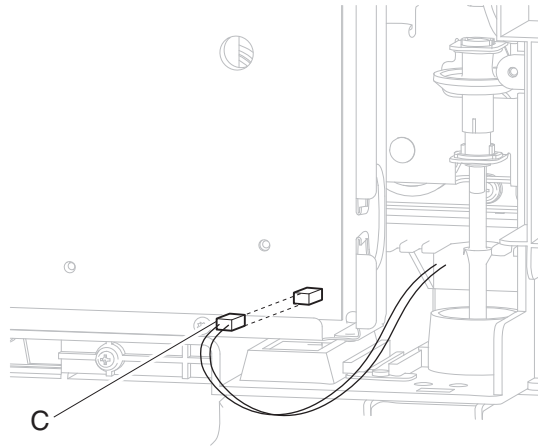

## MPF tray door assembly removal (T650, T652, T654)

1. Open the operator panel door assembly.
2. Open the MPF tray door assembly, and position it as shown in the picture.
3. Gently release the two bosses (A) from the slots (B).

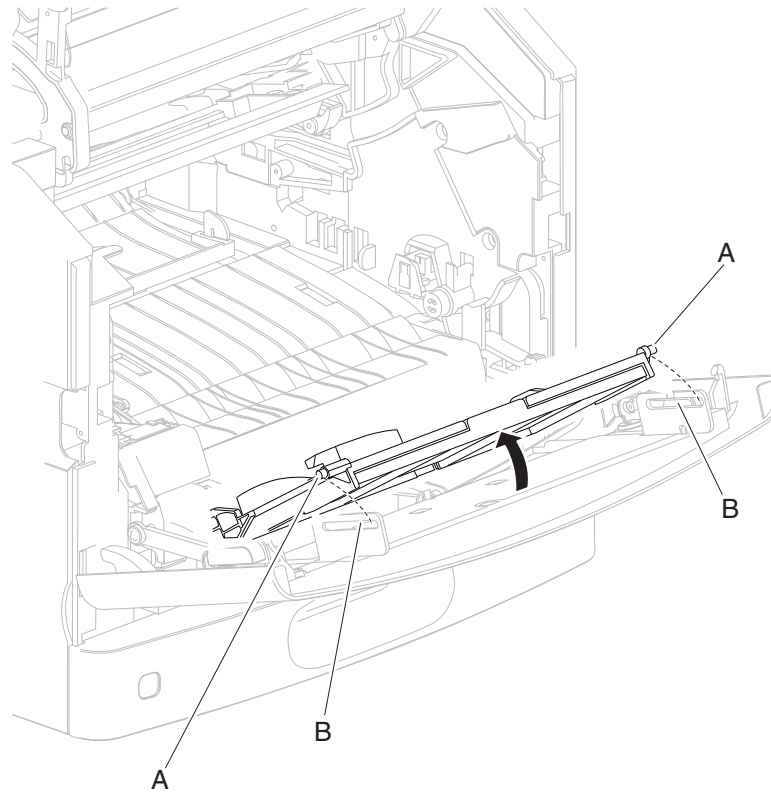

4. While holding the MPF tray in its uppermost position, swing the MPF tray door assembly away from the machine to detach the MPF tray from the machine.

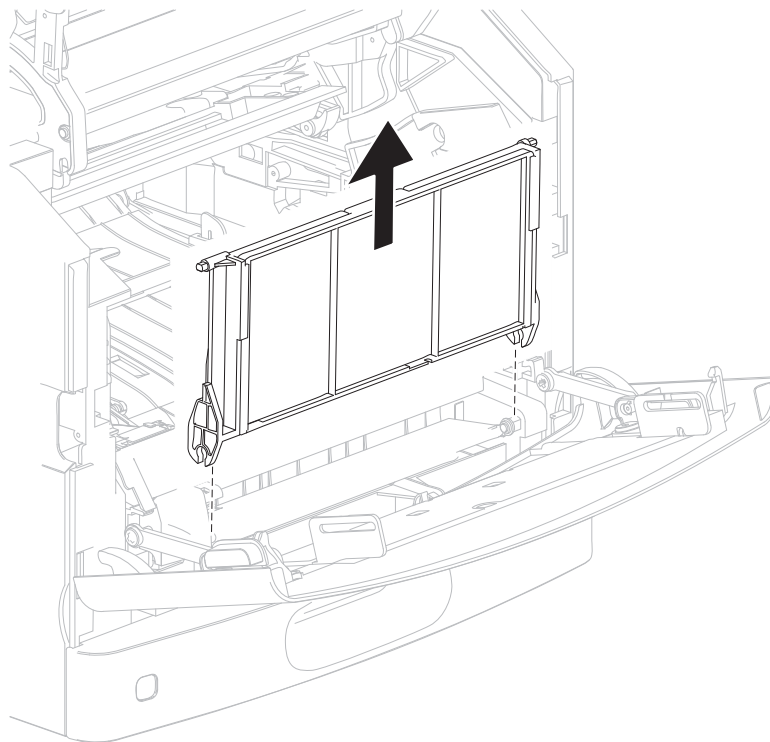



5. Slide the MPF tray door assembly in the direction of the arrow to detach it from the machine.

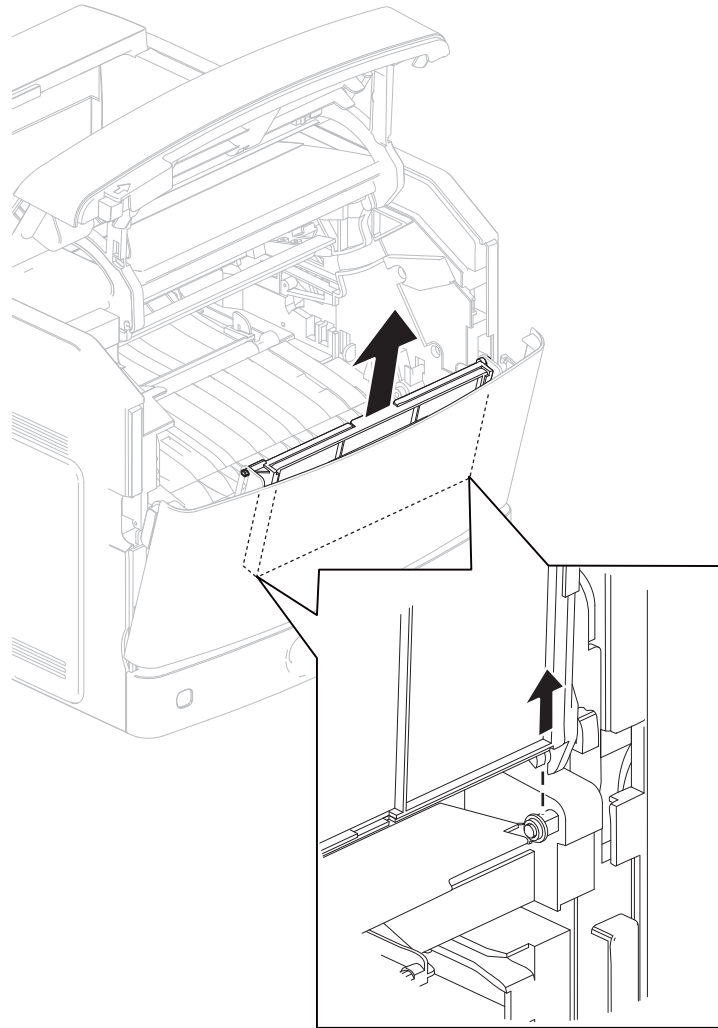

6. Remove the MPF tray door assembly.

### **Operator panel latch assembly removal (T650, T652, T654)**

1. Open the operator panel door assembly.
2. Remove the four screws (A) securing the operator panel latch assembly to the machine.

3. Release the two hooks (B).

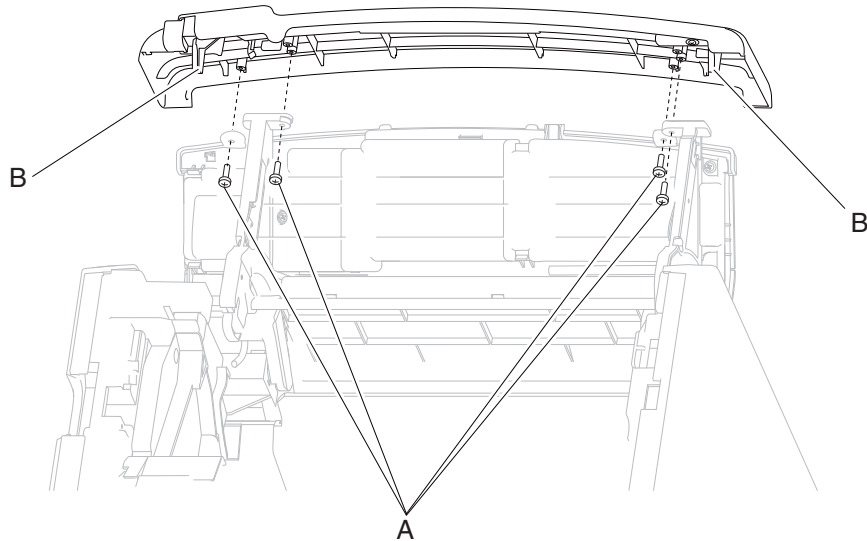

4. Remove the operator panel latch assembly.

### Operator panel door assembly removal (T650, T652, T654)

**Warning:** When replacing any of the following components:

- Operator panel assembly
- System card assembly

Only replace one component at a time. Replace the required component and perform a POR before replacing a second component listed above. If this procedure is not followed, the printer will be rendered inoperable. Never replace two or more of the components listed above without a POR after installing each one or the printer will be rendered inoperable.

Never install and remove components listed above as a method of troubleshooting components. Once a component has been installed in a machine, it can not be used in another machine. It must be returned to the manufacturer.

1. Remove the operator panel latch assembly. Go to **“Operator panel latch assembly removal (T650, T652, T654)” on page 4-43.**
2. Remove the three screws (A) securing the cover to the assembly.
3. Release the three hooks (B) securing the cover to the assembly.

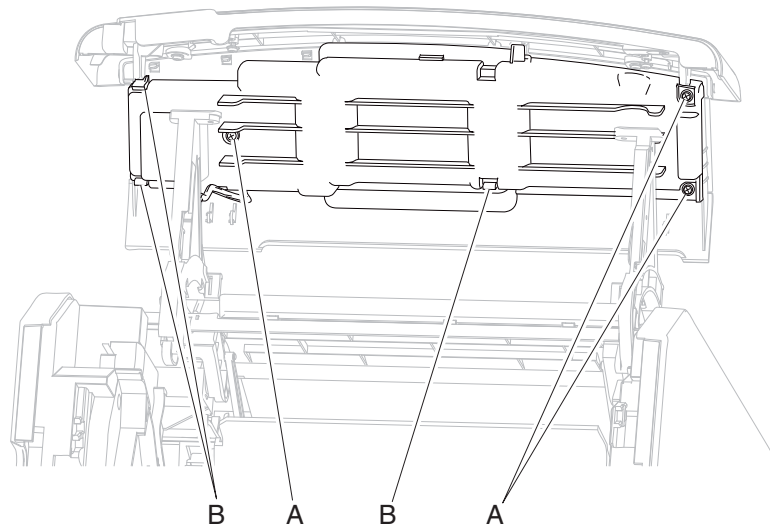

4. Detach the operator panel door assembly from the machine.

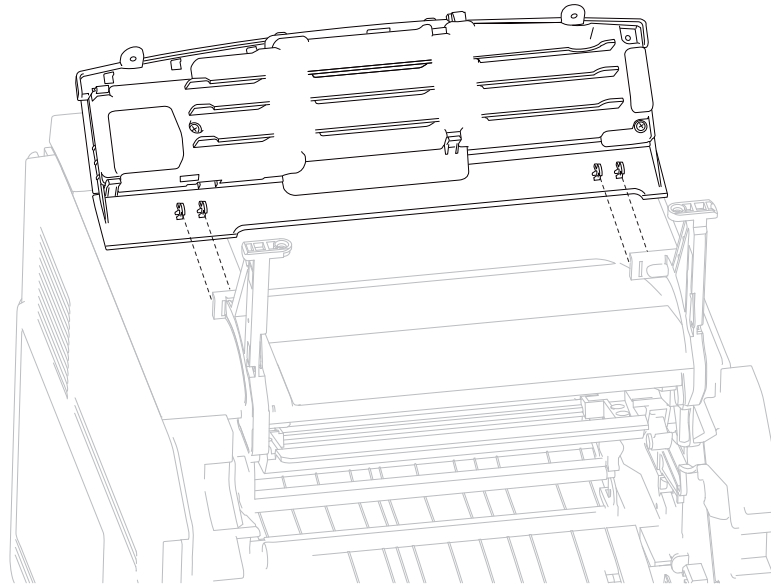

5. Remove the black plastic cover.
6. Remove the two screws (C) securing the USB socket to the assembly.
7. Remove the USB socket.
8. Disconnect the connector (D) from the assembly.

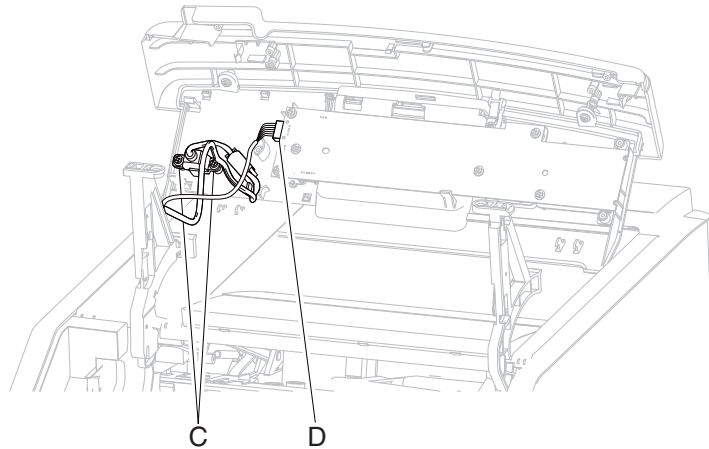

### Operator panel hinge assembly, left removal (T650, T652, T654)

1. Remove the operator panel door assembly. Go to **“Operator panel door assembly removal (T650, T652, T654)” on page 4-44.**
2. Remove the screw (A) securing the cover to the operator panel hinge assembly, left.
3. Remove the cover.
4. Detach the switch (B) from the operator panel hinge assembly, left.

5. Remove the harnesses (C) from the operator panel hinge assembly, left.

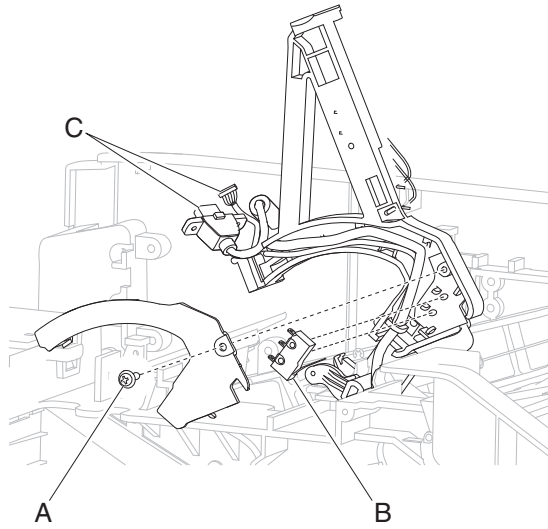

6. Detach the spring (D) from the operator panel hinge assembly, left.
7. Detach the spring (E) from the operator panel hinge assembly, left.
8. Remove the E-clip (F) from the operator panel hinge assembly, left.
9. Remove the pin (G) from the operator panel hinge assembly, left.

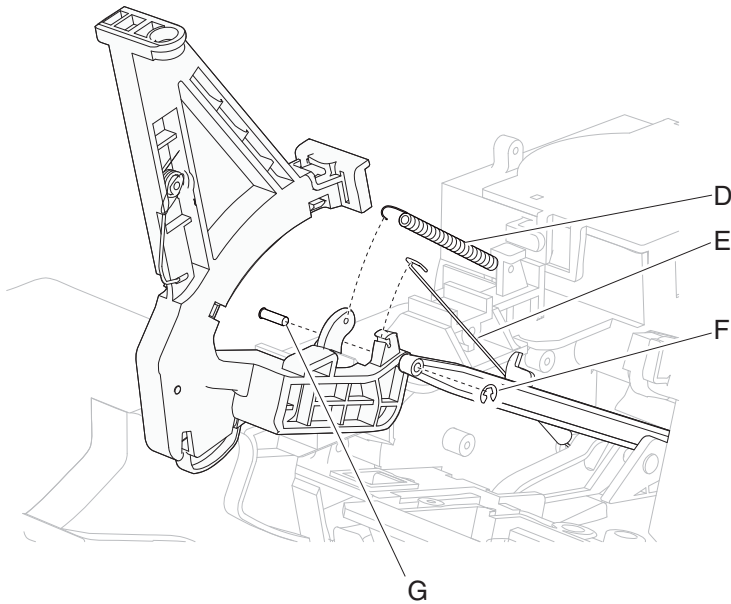

10. Remove the operator panel hinge assembly, left.

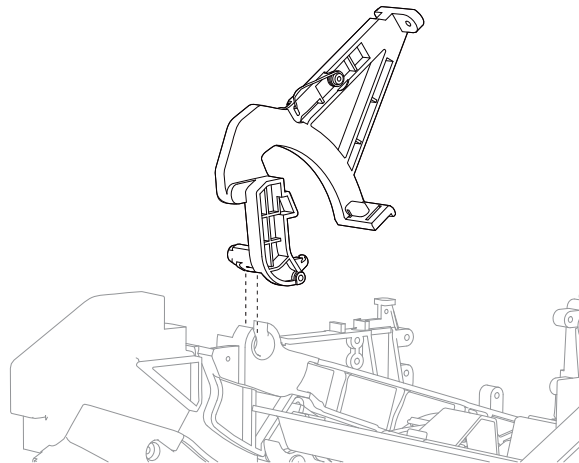

### Operator panel hinge assembly, right removal (T650, T652, T654)

1. Remove the operator panel door assembly. Go to **“Operator panel door assembly removal (T650, T652, T654)” on page 4-44.**
2. Detach the spring (A) from the operator panel hinge assembly, right.
3. Detach the spring (B) from the operator panel hinge assembly, right.

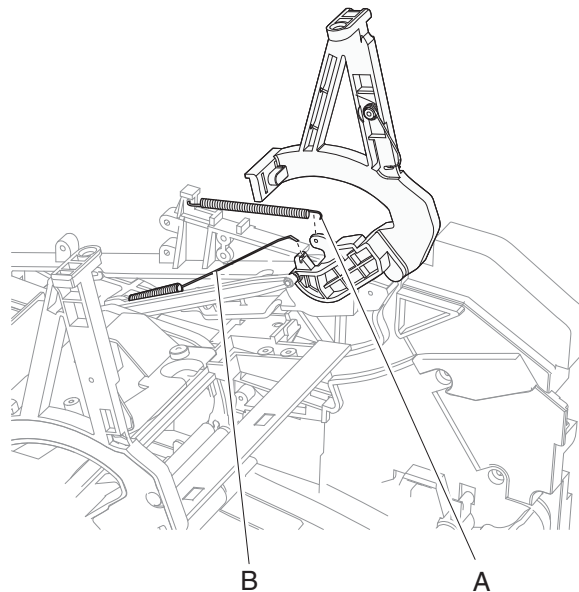

4. Remove the E-clip (C) from the operator panel hinge assembly, right.

5. Remove the pin (D) from the operator panel hinge assembly, right.

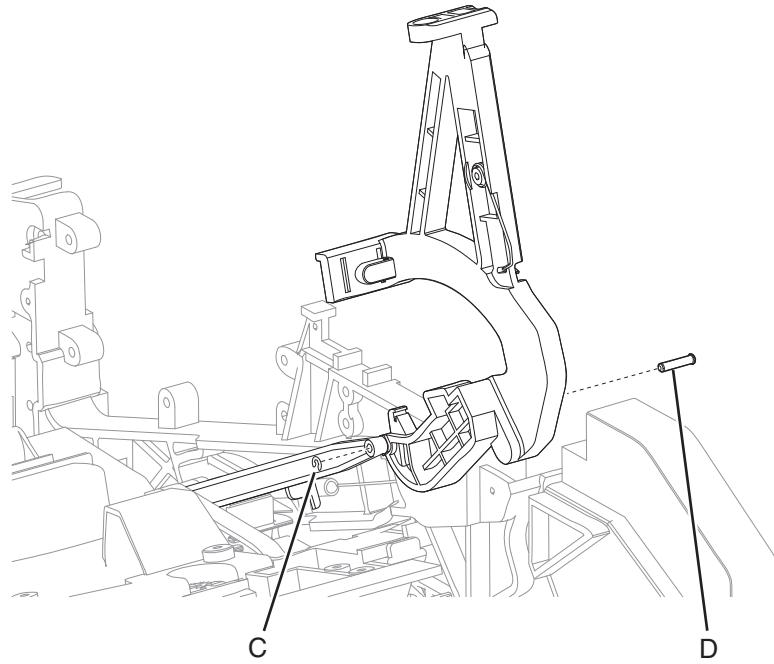

6. Remove the operator panel hinge assembly, right.

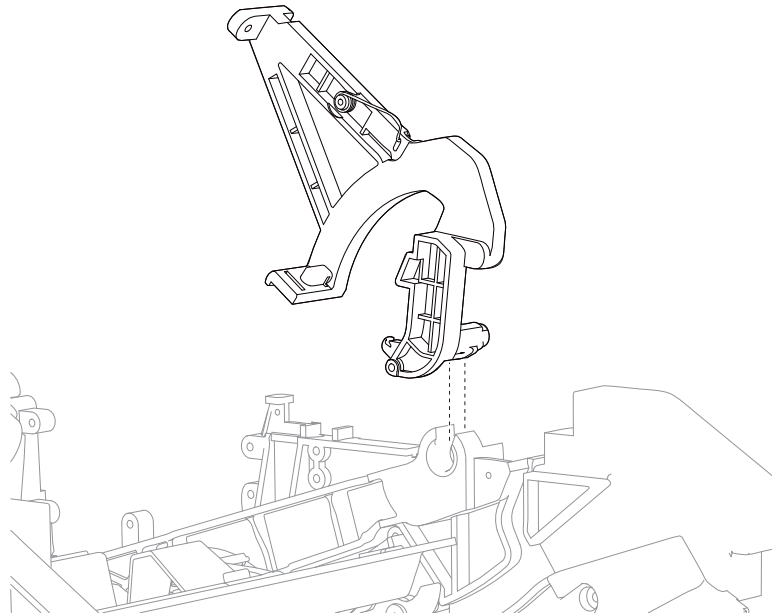

## Operator panel door assembly removal (models X651, X652, X654, and X656)

**Warning:** When replacing any of the following components:

- Operator panel assembly
- System card assembly

Only replace one component at a time. Replace the required component and perform a POR before replacing a second component listed above. If this procedure is not followed, the printer will be rendered inoperable. Never replace two or more of the components listed above without a POR after installing each one or the printer will be rendered inoperable.

Never install and remove components listed above as a method of troubleshooting components. Once a component has been installed in a machine, it can not be used in another machine. It must be returned to the manufacturer.

1. Remove the laser cover. See **“Laser cover removal (models X651, X652, X654, and X656)” on page 4-105.**
2. Remove the counter balance springs (A) on both sides.
3. Remove the print cartridge cover springs (B) on both sides.
4. Remove the E-clips (C) on both sides securing the links to the hinges, and remove the links.
5. Remove the pins (D) on both sides securing the links.

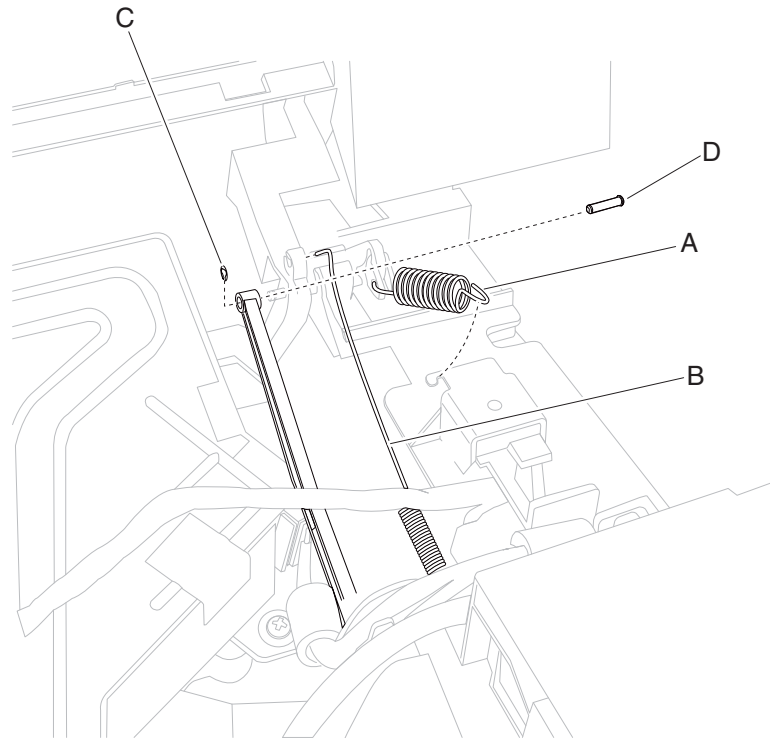

6. Remove eight screws (E) securing the scanner controller cage cover to the cage. An X658 model is represented in the graphic below, however, the card cage cover removal procedure is similar for all models.

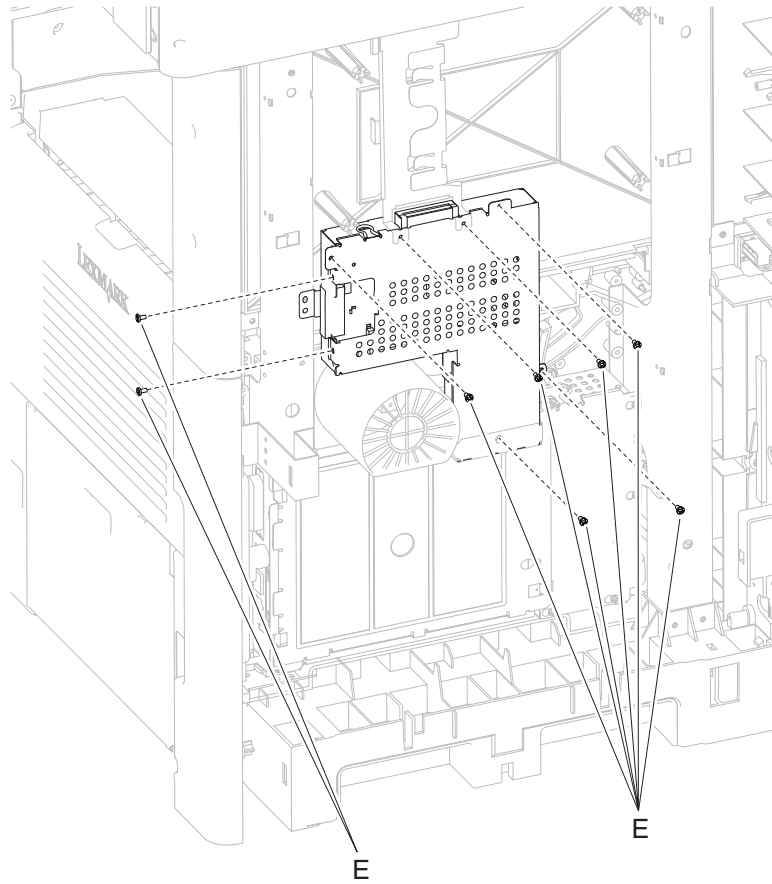

7. Remove the printer controller card cage cover.

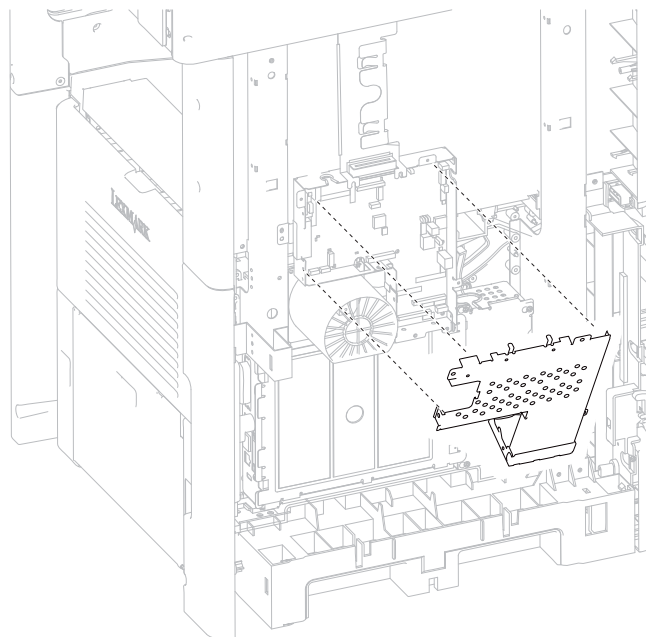

8. Disconnect the USB cable and the cover closed interlock switch harness.



9. Lift the operator panel door assembly out of the machine.

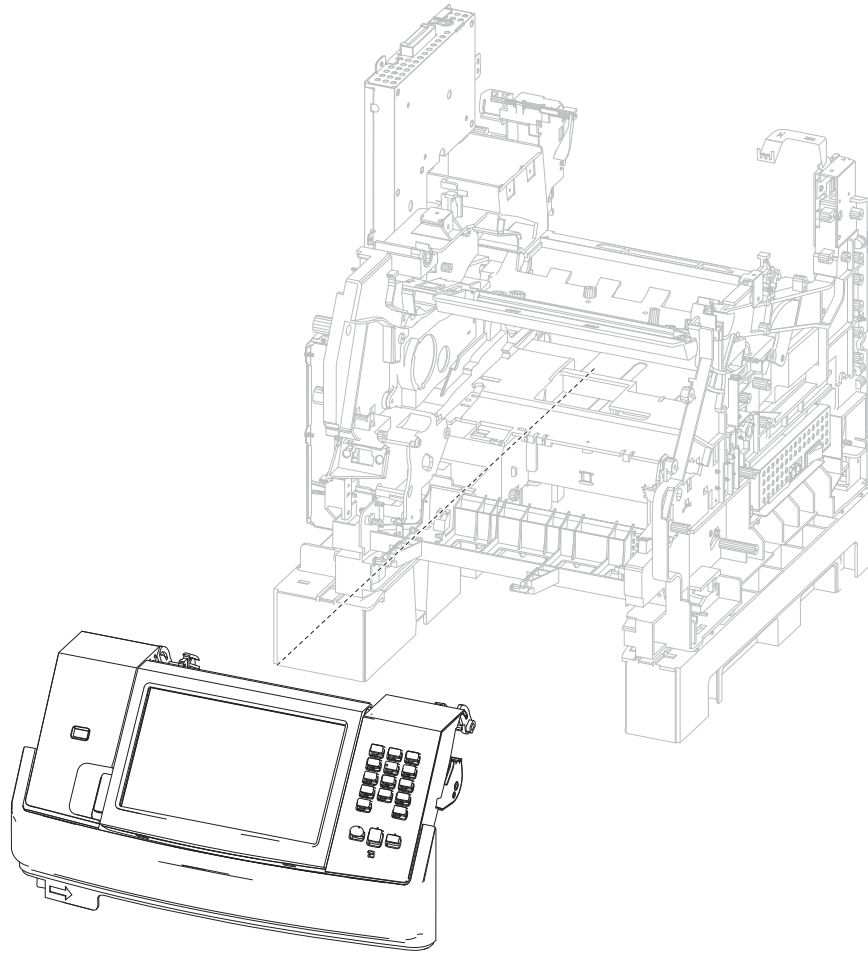

### ***Operator panel cover latch assembly removal (models X651, X652, X654, and X656)***

1. Lift the operator panel cover assembly.
2. Remove the ten screws (A) securing the operator panel cover latch assembly to the operator panel cover assembly.

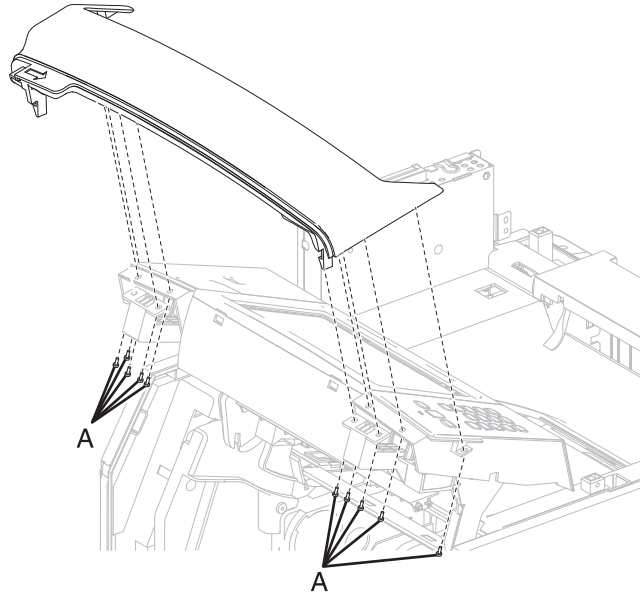

3. Remove the operator panel cover latch assembly.

### **Option drive shaft removal (T650, T652, T654)**

1. Gently place the printer on its left or right side.
2. Using pliers, gently pull the option drive shaft from the machine.

3. Remove the spring.

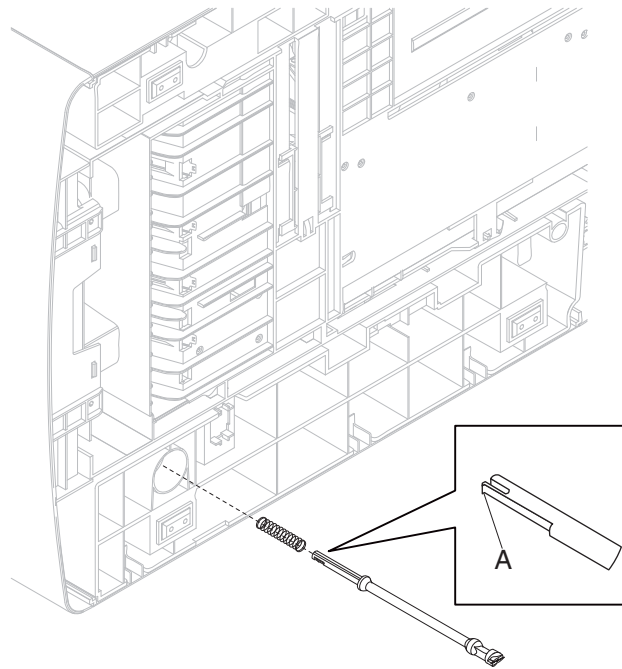

**Replacement Warning:** When replacing the option drive shaft, ensure that the plastic hook (A) is not damaged, or the option drive shaft will not remain secured.

## Output cover assembly removal (T650, T652, T654)

1. Unsnap the output cover assembly from the machine.

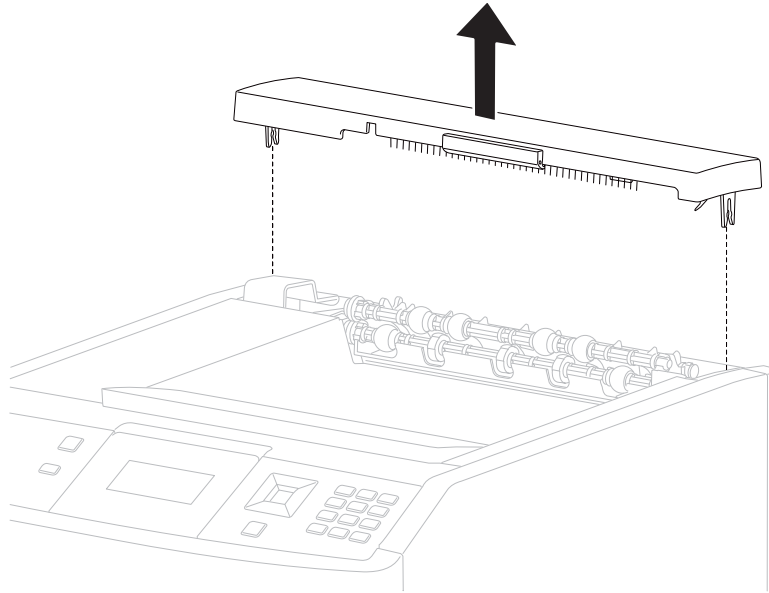

2. Remove the output cover assembly.

## Pick arm assembly removal (T650, T652, T654)

1. Remove the media tray from the machine.
2. Place the machine on the left or right side.
3. Remove the spring (A).

4. Remove the two E-clips (B) securing the pick arm assembly to the machine.

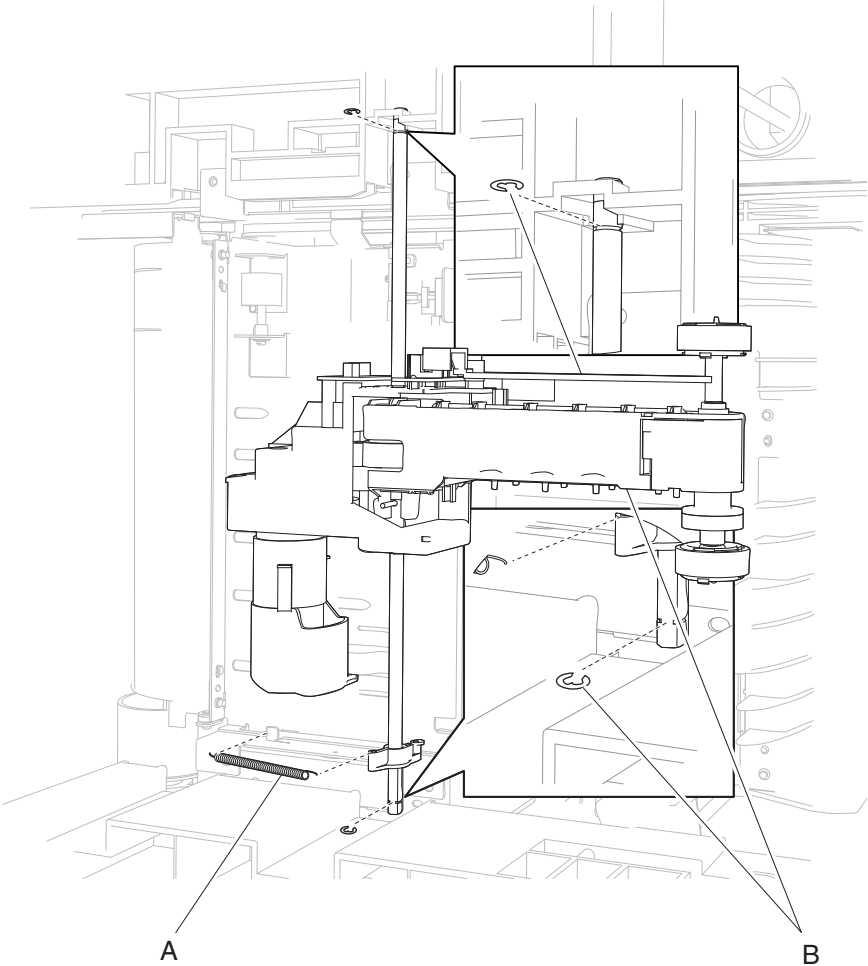

5. Remove the screw (C) securing the pick arm assembly to the machine.

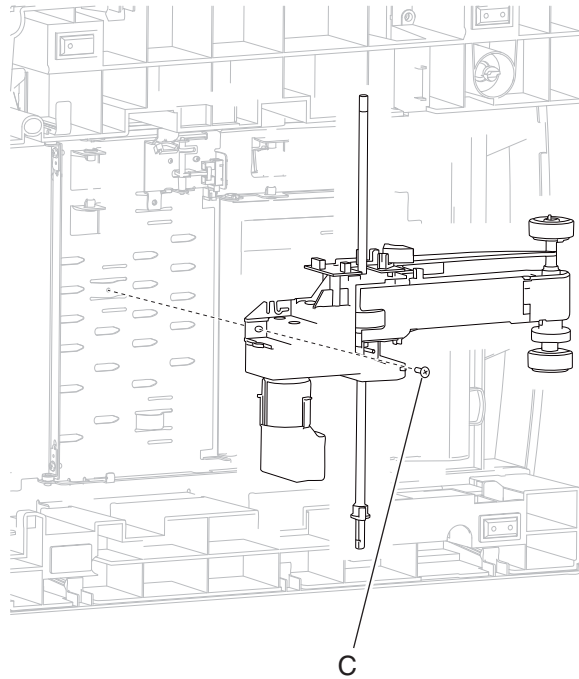

6. Remove the band (D) from the pick arm assembly.
7. Remove the cover from the pick arm assembly.
8. Remove the three connections (E) from the pick arm assembly.
9. Remove the wiring harness (F) from the pick arm assembly.

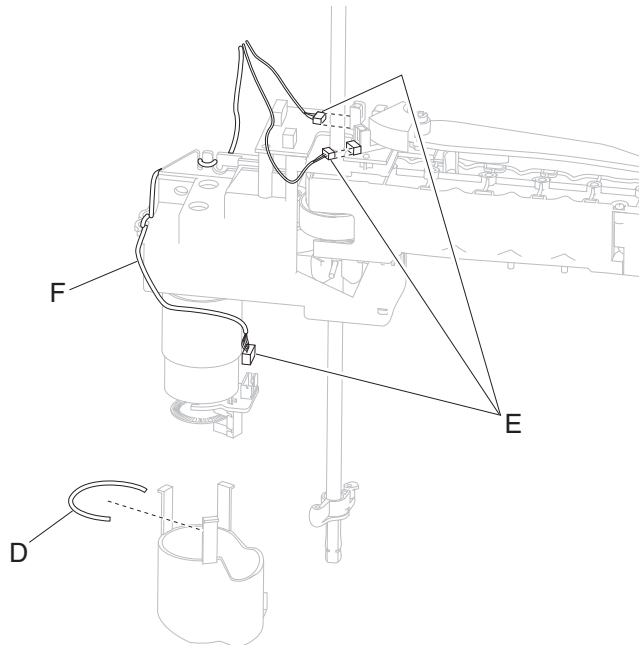

10. Remove the pick arm assembly.

**Replacement Warning:** When replacing the pick arm assembly, ensure that the harnesses are properly re-routed.

**Replacement Warning:** When replacing the pick arm assembly, ensure that the connections are properly replaced.

## Pick roll assembly removal (T650, T652, T654)

1. Remove the media tray.
2. Gently pull the pick arm assembly down, and release the two hooks (A) securing the two pick roll assemblies.

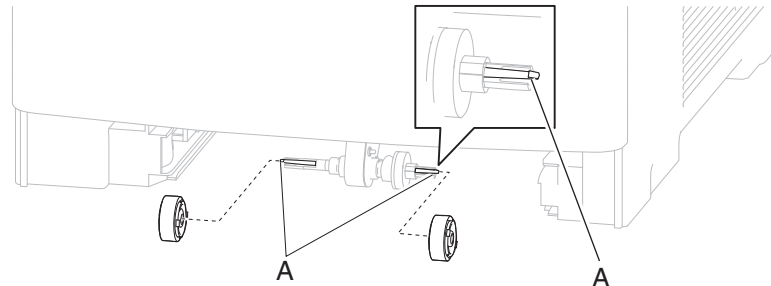

3. Remove the two pick roll assemblies.

**Replacement Warning:** When replacing the pick roll assembly, do not touch the rubber surface.

## Print cartridge cooling fan removal (T650, T652, T654)

1. Remove the side cover, right. Go to **“Side cover, right removal (T650)”** on page 4-67 or **“Side cover, right removal (T652, T654)”** on page 4-68.
2. Remove the screw (A) securing the print cartridge cooling fan to the machine.
3. Remove the print cartridge cooling fan.
4. Disconnect the connection (B) from the print cartridge cooling fan.

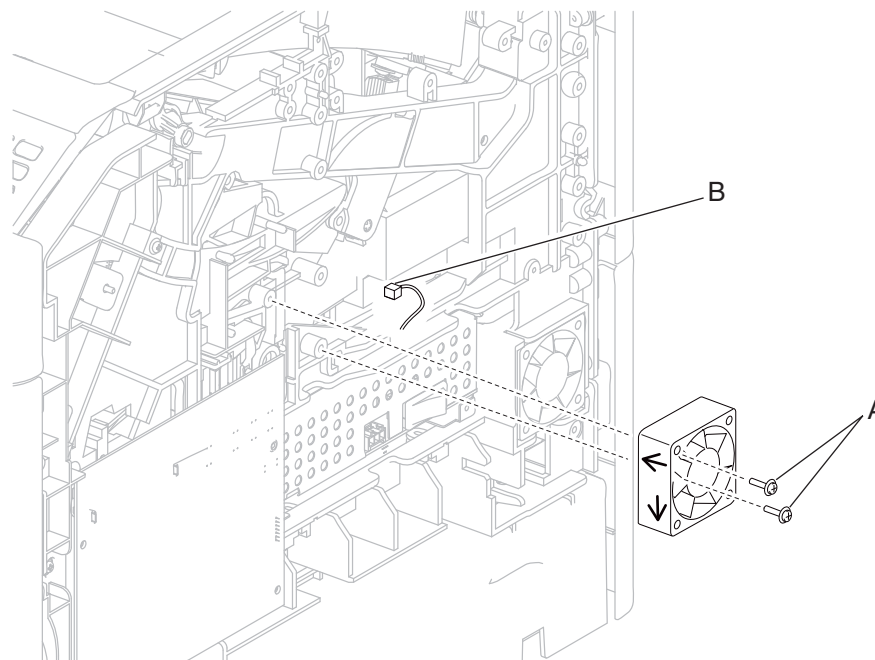

**Replacement Warning:** When replacing the print cartridge cooling fan, ensure that it is installed as shown in the picture.

## Print cartridge clamp assembly removal (T650, T652, T654)

**Note:** This procedure can be applied to the left or right printer cartridge hold down assembly.

1. Remove the laser cover. Go to **“Laser cover removal (T650, T652, T654)”** on page 4-27.
2. Remove the screw (A) securing the print cartridge clamp assembly to the machine.

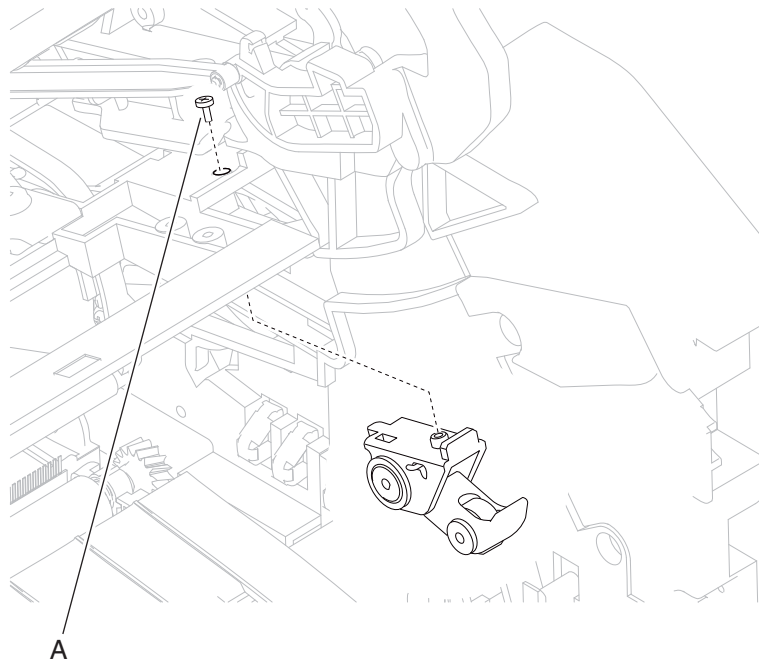
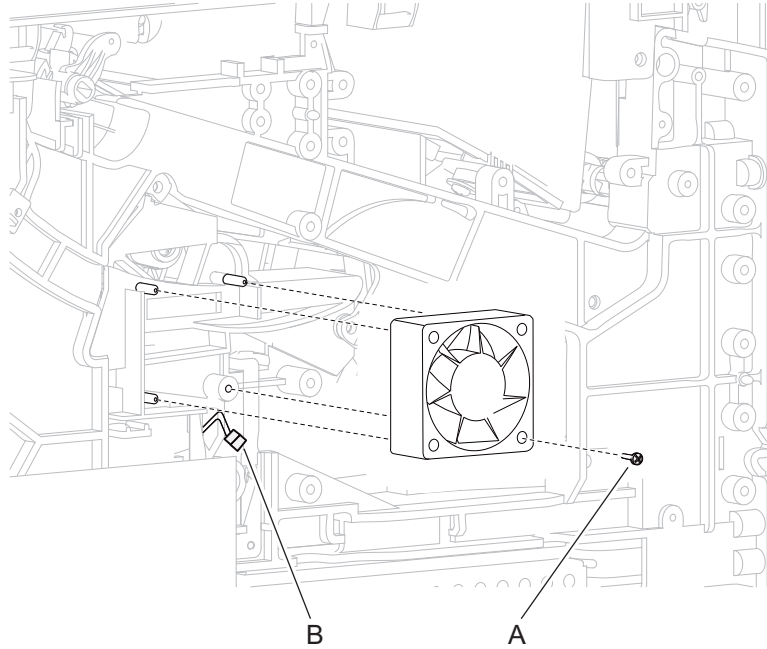

3. Remove the print cartridge clamp assembly.



## Print cartridge ID connector assembly removal (T650, T652, T654)

1. Remove the print cartridge.
2. Remove the main drive motor assembly. Go to **“Output cover assembly removal (T650, T652, T654)” on page 4-54.**
3. Release the two hooks (A) securing the print cartridge ID connector assembly to the machine.

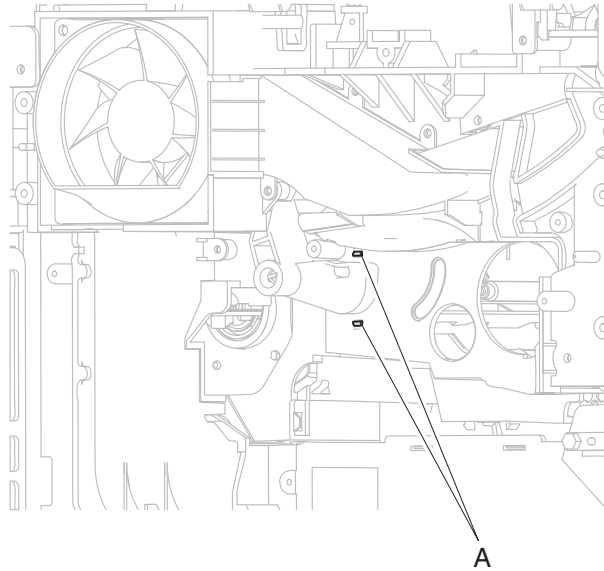

4. Remove the print cartridge ID connector assembly.
5. Disconnect the connection (B) from the print cartridge ID connector assembly.

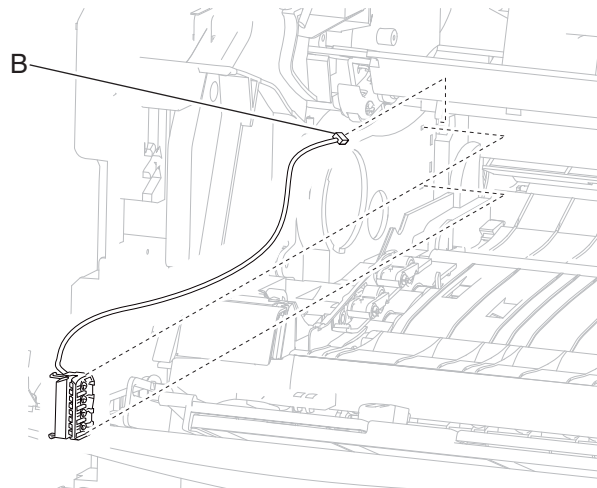

## Printhead assembly removal (T650)

**Note:** When replacing the printhead assembly, ensure that the printhead is properly calibrated, or print quality issues will occur. Go to **“Alignment assembly adjustment” on page 4-4.**

1. Remove the laser cover. Go to **“Laser cover removal (T650, T652, T654)” on page 4-27.**
2. Remove the six screws (A) securing the metal cover to the machine.

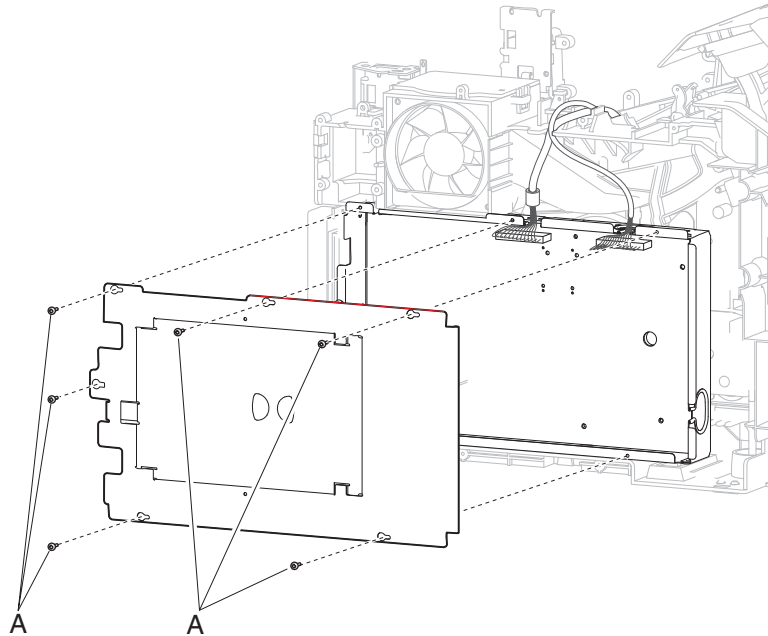

3. Remove the metal cover.
4. Disconnect the connections (B) from the printhead assembly.

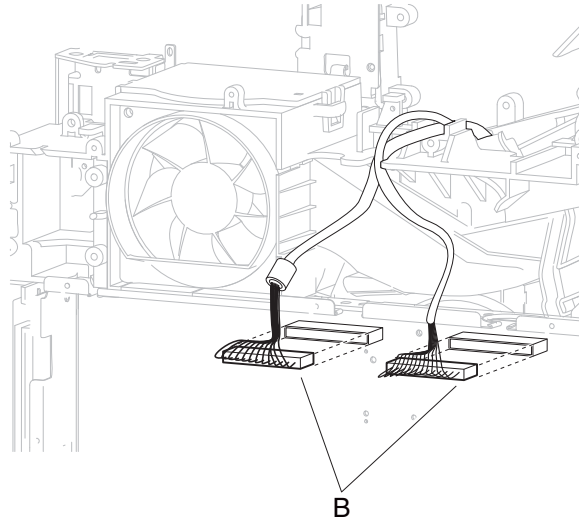

- Remove the three screws (C) securing the printhead assembly to the machine.

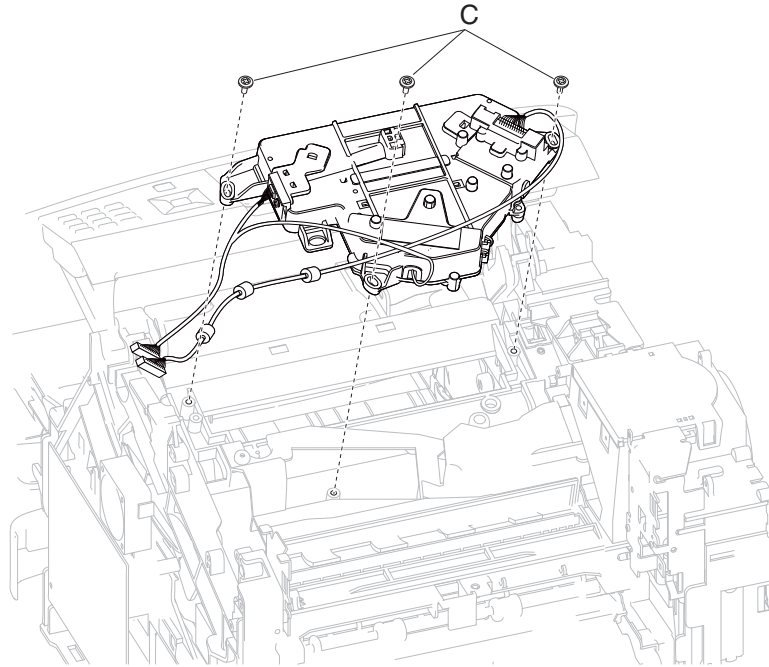

- Remove the printhead assembly.

**Replacement Warning:** When replacing the printhead assembly, ensure that the printhead is properly calibrated, or print quality issues will occur.

### Printhead assembly removal (T652, T654)

**WARNING:** When replacing the printhead assembly, ensure that the printhead skew is properly adjusted, or print quality issues will occur.

- Remove the laser cover. Go to **“Laser cover removal (T650, T652, T654)”** on page 4-27.
- Remove the six screws (A) securing the metal cover to the machine.

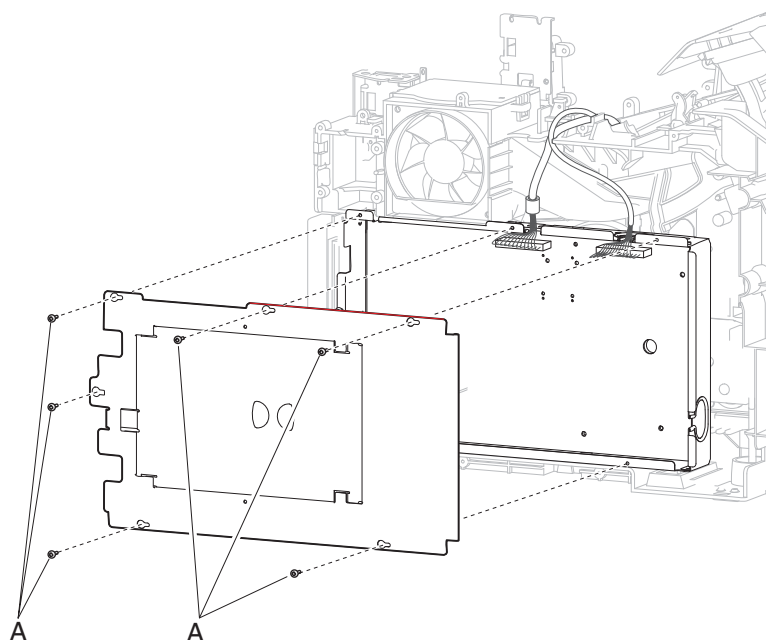

3. Remove the metal cover.
4. Disconnect the connections (B) from the printhead assembly.

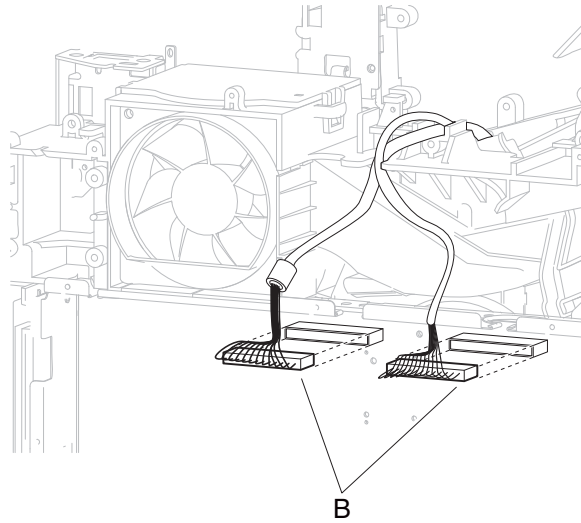

5. Remove the four screws (C) securing the printhead assembly to the machine.

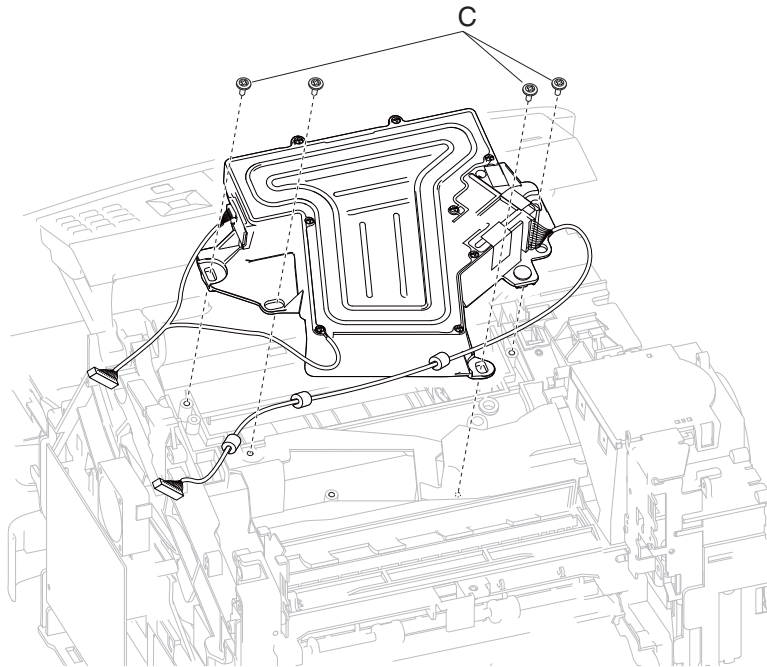

6. Remove the printhead assembly.

**Replacement Warning:** When replacing the printhead assembly, ensure that the printhead skew is properly adjusted, or print quality issues will occur.

### Redrive assembly removal (T650, T652, T654)

1. Remove the door assembly, rear. Go to **“Door assembly, rear removal (T650, T652, T654)”** on **page 4-15**.
2. Open the fuser access door.
3. Remove the two screws (A) securing the redrive assembly to the machine.
4. Press the two tabs (B) to release the redrive assembly to the machine.

5. While pressing the two tabs (B), pull the redrive assembly from the machine.

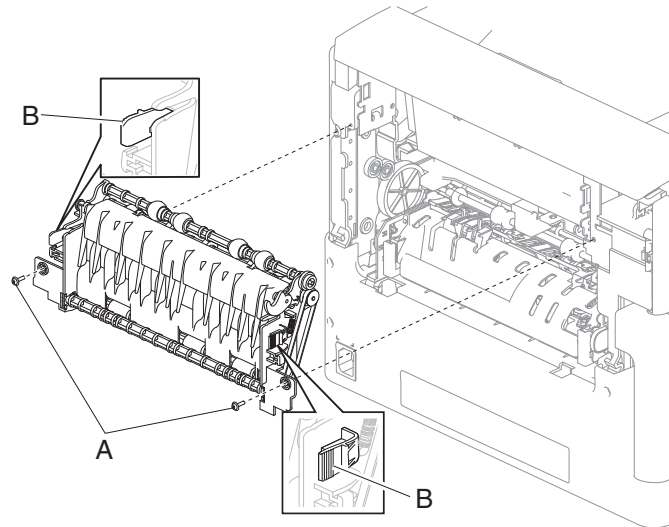

### Redrive motor assembly removal (T652, T654)

1. Remove the laser cover. Go to **“Laser cover removal (T650, T652, T654)”** on page 4-27.
2. Remove the six screws (A) securing the metal cover to the machine.

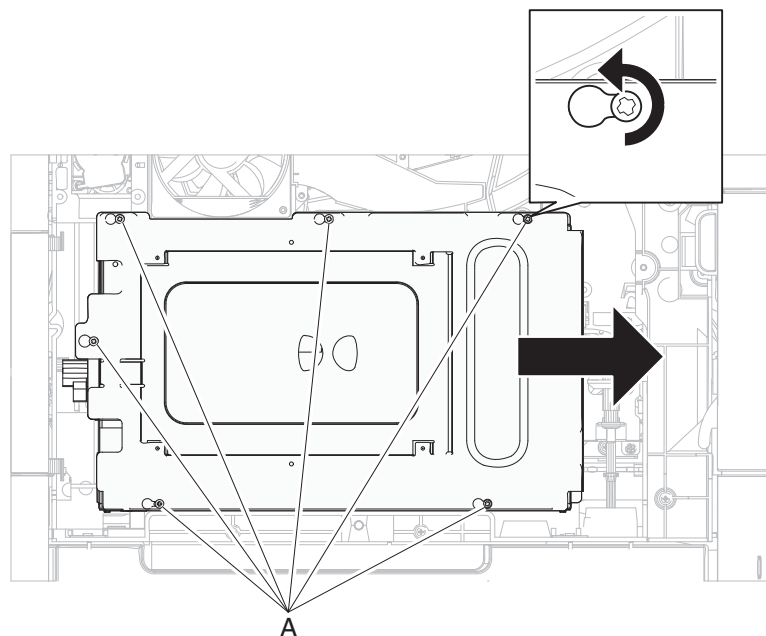

3. Remove the metal cover.

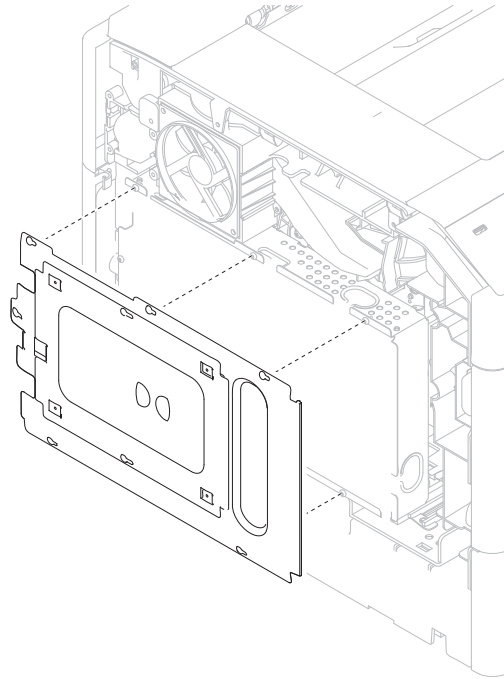

4. Disconnect the connection (B) from the redrive motor assembly.

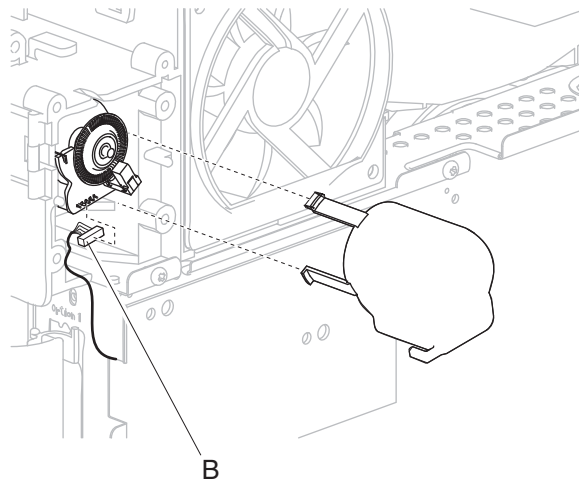

5. Disconnect the connection (C) from the sensor (standard media bin full).

6. Release the hooks (D) securing the output option interface cable assembly to the machine.

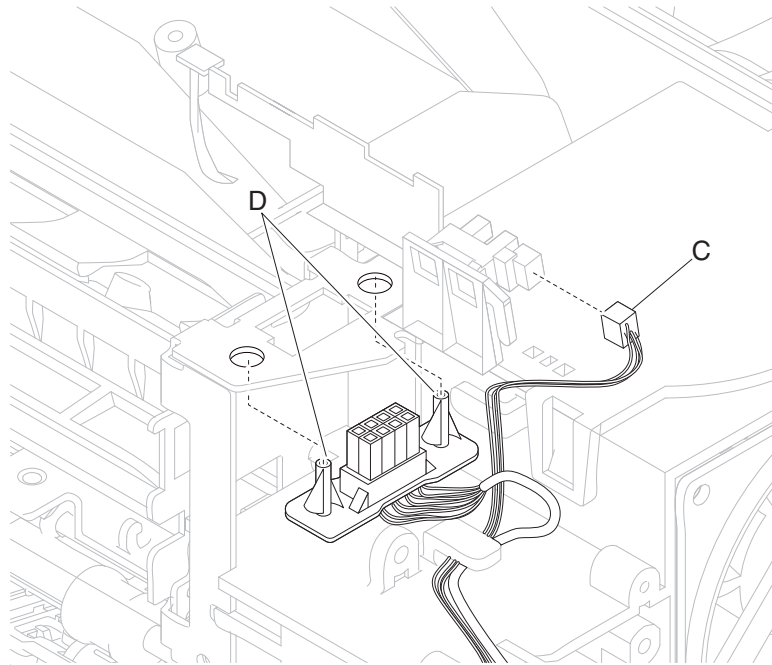

7. Detach the output option cable assembly.
8. Remove the two screws (E) securing the redrive motor assembly to the machine.

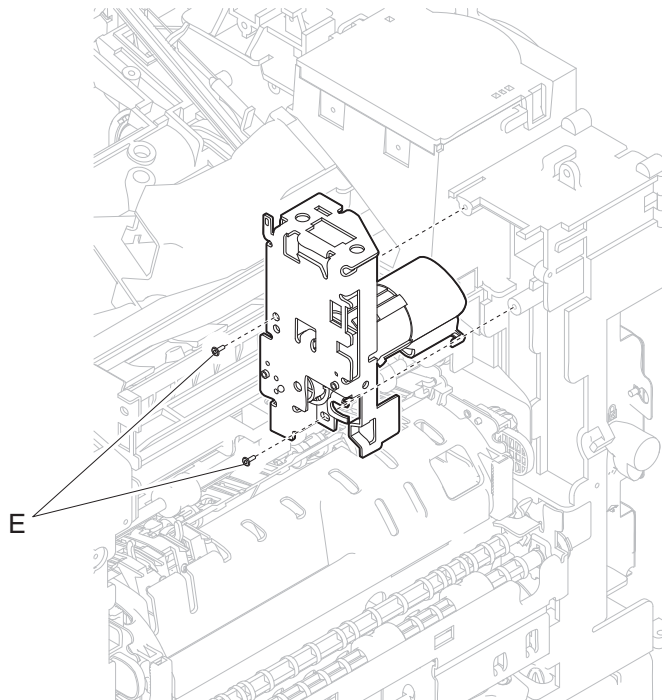

9. Remove the redrive motor assembly.

### Side cover, left removal (T650)

1. Open the MPF tray door assembly.
2. Open the operator panel door assembly.

3. Remove the cover assembly, rear lower. Go to **“Cover assembly, rear lower removal (T650)” on page 4-13.**
4. Remove the four screws (A) securing the side cover, left to the machine.

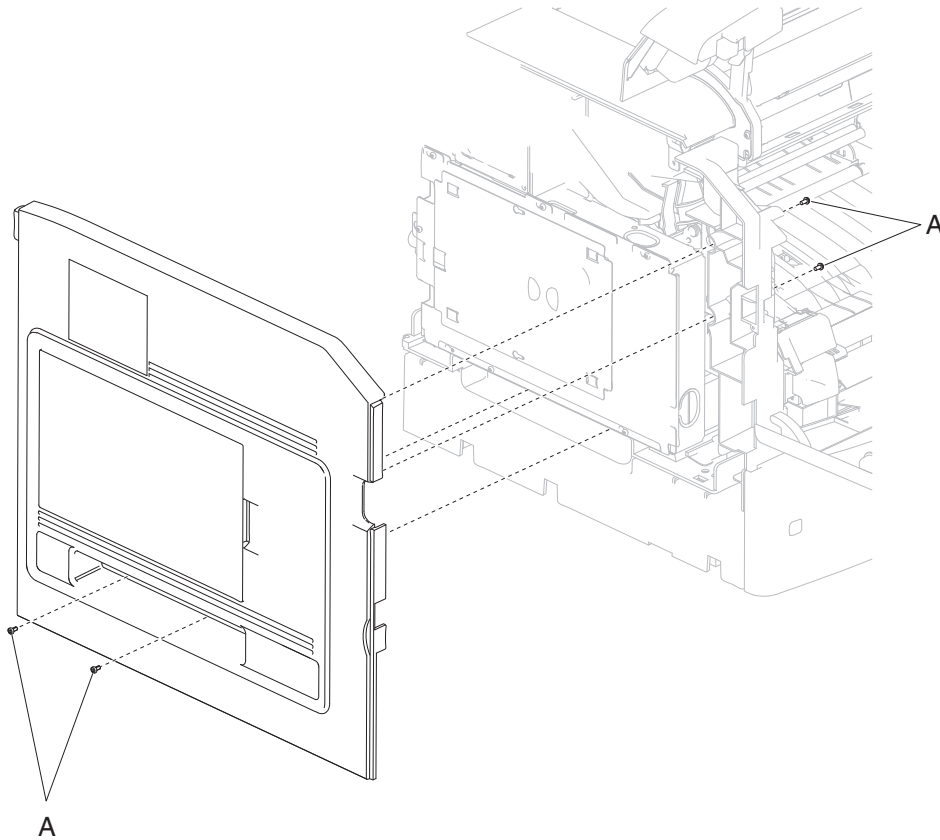

5. Swing the side cover, left away from the machine.
6. Remove the side cover, left.

### Side cover, left removal (T652 and T654)

1. Open the MPF tray door assembly.
2. Open the operator panel door assembly.
3. Remove the cover assembly, rear lower. Go to **“Cover assembly, rear lower removal (T650)” on page 4-13** or **“Cover assembly, rear lower (T652, T654)” on page 4-13.**



- Remove the four screws (A) securing the side cover, left to the machine.

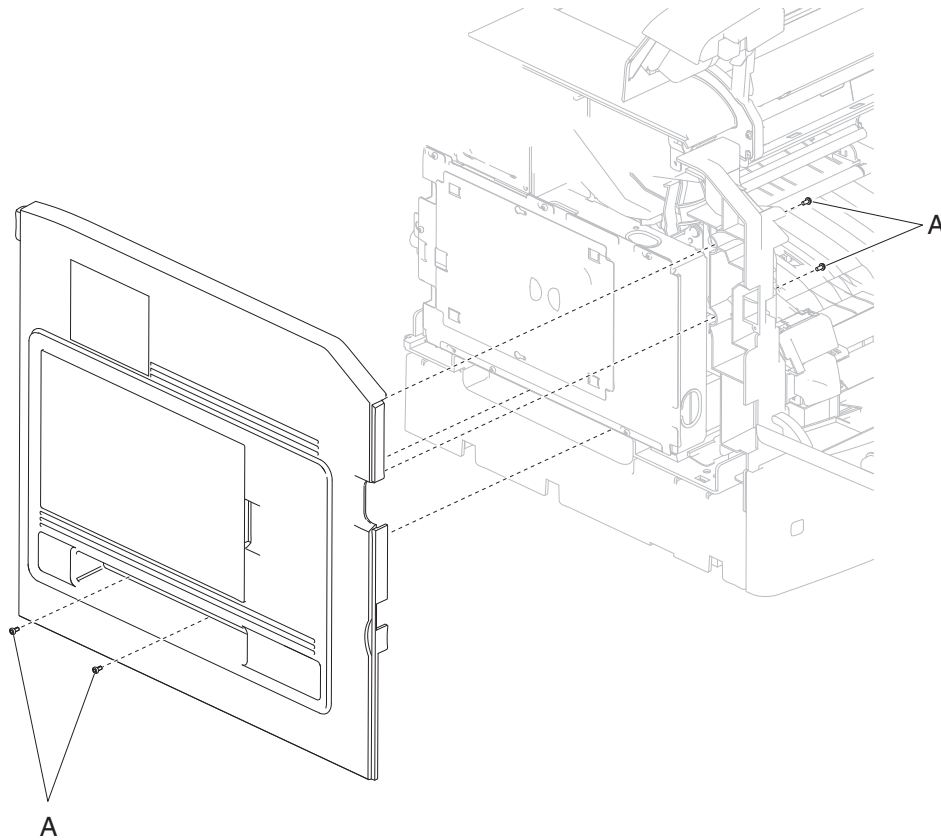

- Swing the side cover, left away from the machine.
- Remove the side cover, left.

### Side cover, right removal (T650)

- Open the operator panel door assembly.
- Open the MPF tray door assembly.
- Remove the cover assembly, rear lower. Go to **“Cover assembly, rear lower removal (T650)” on page 4-13.**

4. Remove the five screws (A) securing the side cover, right to the machine.

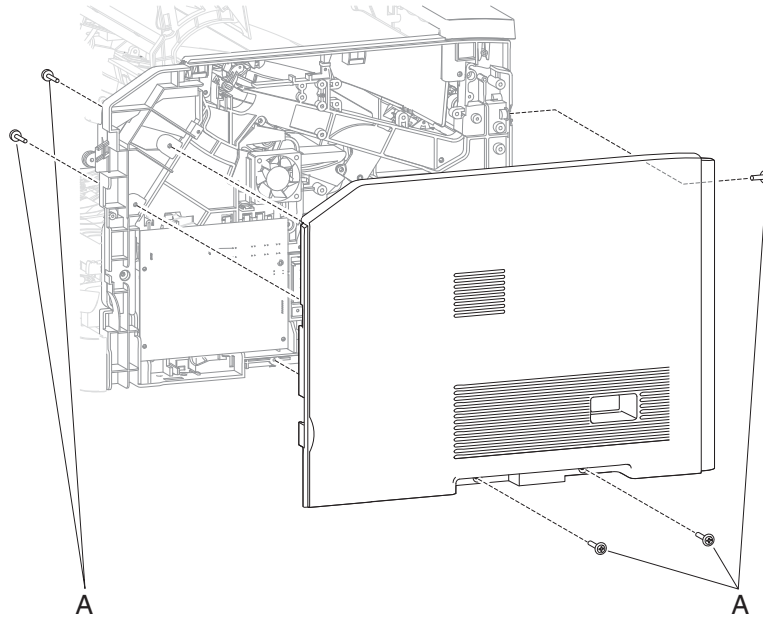

5. Remove the side cover, right.

### Side cover, right removal (T652, T654)

1. Open the operator panel door assembly.
2. Open the MPF tray door assembly.
3. Remove the cover assembly, rear lower. Go to **“Cover assembly, rear lower (T652, T654)” on page 4-13.**
4. Remove the five screws (A) securing the side cover, right to the machine.

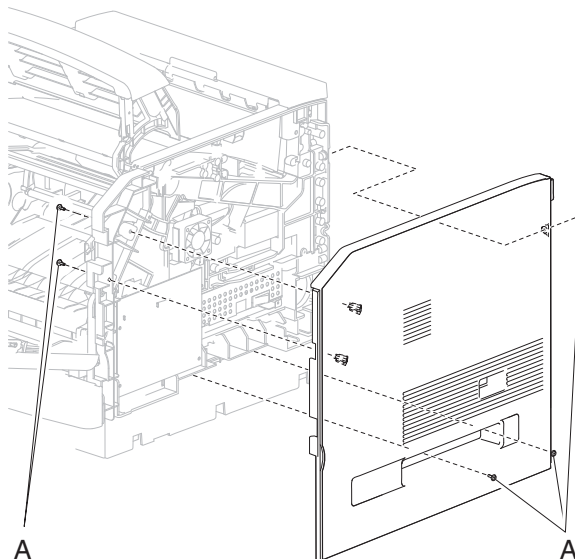

5. Remove the side cover, right.

### Sensor (duplex input) removal (T652, T654)

1. Remove the duplex input sensor assembly. Go to **“Duplex input sensor assembly removal (T652, T654)” on page 4-20.**

2. Release the hooks (A) securing the sensor (duplex media path) to the bracket.

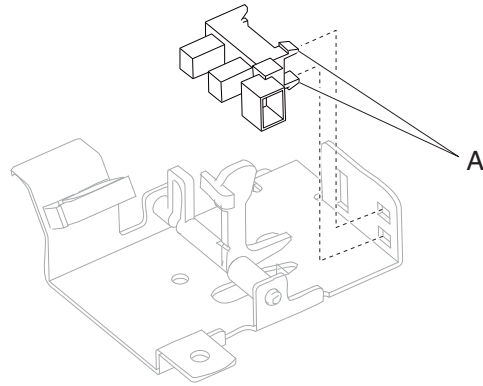

3. Remove the sensor (duplex input).

### Sensor (media level) removal (T650, T652, T654)

1. Remove the pick arm assembly. Go to **“Operator panel door assembly removal (models X651, X652, X654, and X656)” on page 4-49.**
2. Release the hooks (A) securing the sensor (media level) to the assembly.

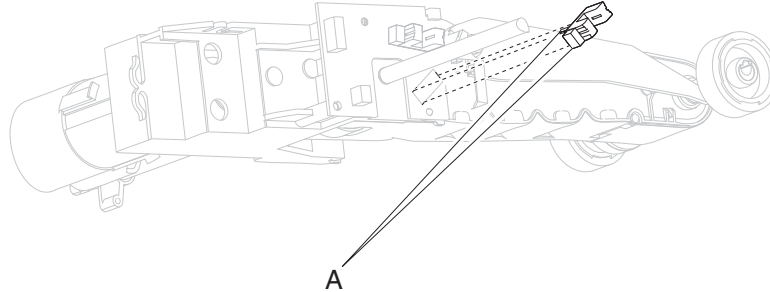

3. Remove the sensor (media level).

### Sensor (media out) removal (T650, T652, T654)

1. Remove the pick arm assembly. Go to **“Operator panel door assembly removal (models X651, X652, X654, and X656)” on page 4-49.**
2. Release the hooks (A) securing the sensor (media out) to the assembly.

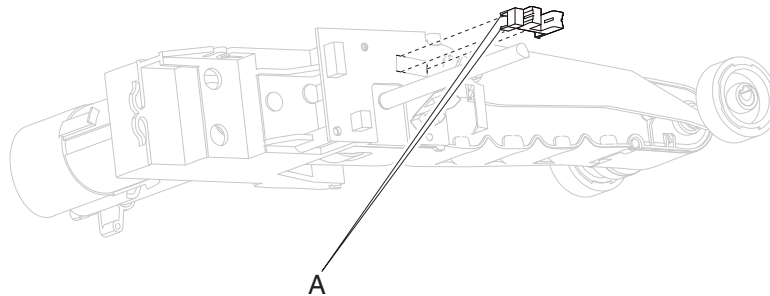

3. Remove the sensor (media out).

## Sensor (toner empty) removal (T650, T652, T654)

1. Remove the HVPS card assembly. Go to **"HVPS card assembly removal (T650, T652, T654)"** on **page 4-24**.
2. Remove the screw (A) securing the sensor (toner empty) to the machine.
3. Remove the sensor (toner empty).
4. Disconnect the connection (B) from the sensor (toner empty).

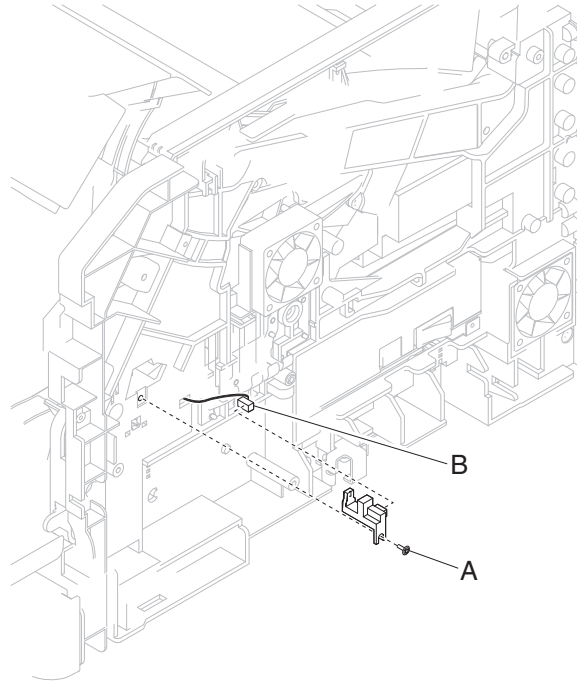

## Sensor (input) removal (T650, T652, T654)

1. Remove the inner deflector. Go to **"Inner deflector removal (T650, T652, T654)"** on **page 4-25**.
2. Release the hooks (A) securing the sensor (input) to the machine.

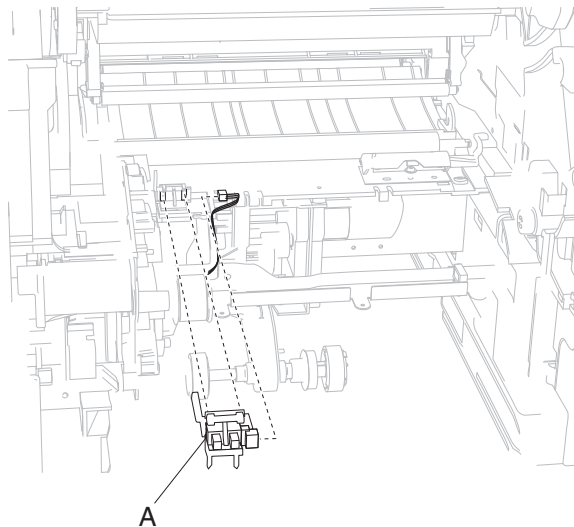

3. Remove the sensor (input).

4. Disconnect the connection (B) from the sensor (input).

### Sensor shield assembly removal (T650, T652, T654)

1. Remove the inner deflector. Go to **“Inner deflector removal (T650, T652, T654)”** on page 4-25.
2. Gently unsnap the sensor shield assembly from the machine.

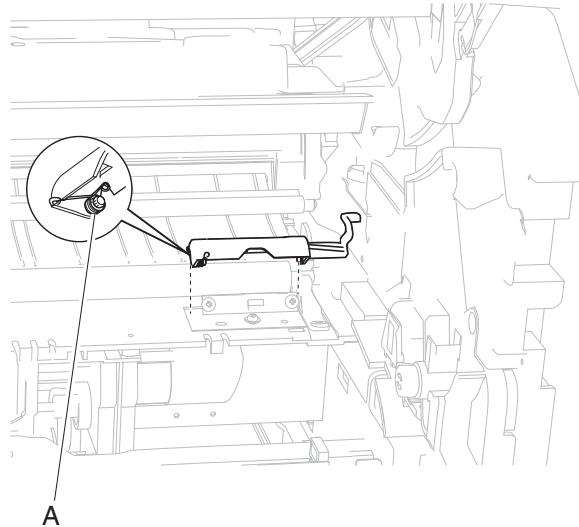

3. Remove the sensor shield assembly.

**Replacement Warning:** When replacing the sensor shield assembly, ensure that the spring (A) is properly aligned and the sensor shield assembly opens and closes properly.

## Sensor (standard bin exit) removal (T650, T652, T654)

1. Remove standard bin actuator assembly. Go to **“Sensor (standard bin exit) removal (T650, T652, T654)” on page 4-73.**
2. Release the hooks (A) securing the sensor (standard bin exit) to the assembly.

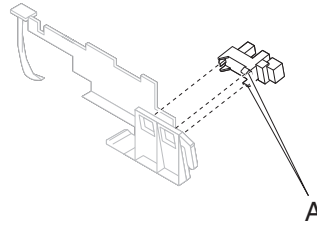

3. Remove the sensor (standard bin exit).

## Sensor (toner density) removal (T650, T652, T654)

1. Remove the sensor shield assembly. Go to **“Sensor shield assembly removal (T650, T652, T654)” on page 4-72.**
2. Remove the two screws (A) securing the sensor (toner density) to the machine.
3. Remove the sensor (toner density).
4. Disconnect the connection (B) to the sensor (toner density).

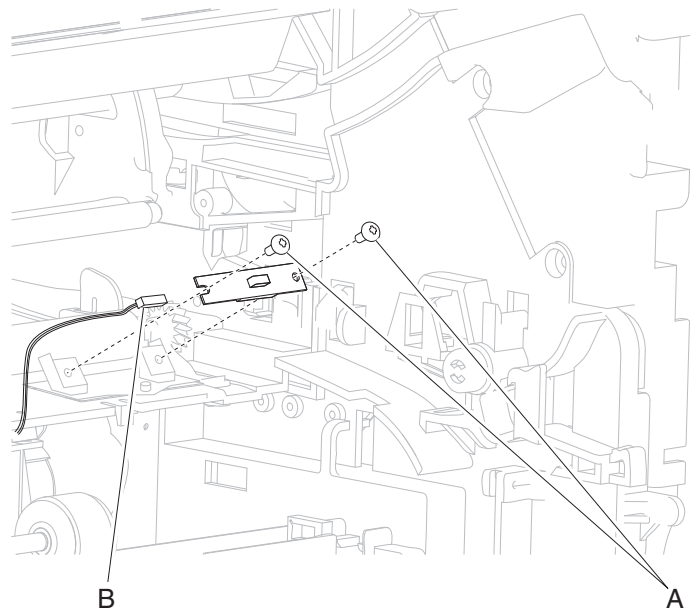

## Standard bin actuator assembly removal (T650, T652, T654)

1. Remove the laser cover. Go to **“Laser cover removal (T650, T652, T654)” on page 4-27.**
2. Disconnect the connection (A) from the standard bin actuator assembly.

3. Press the tab (B) to release the standard bin actuator assembly from the machine.

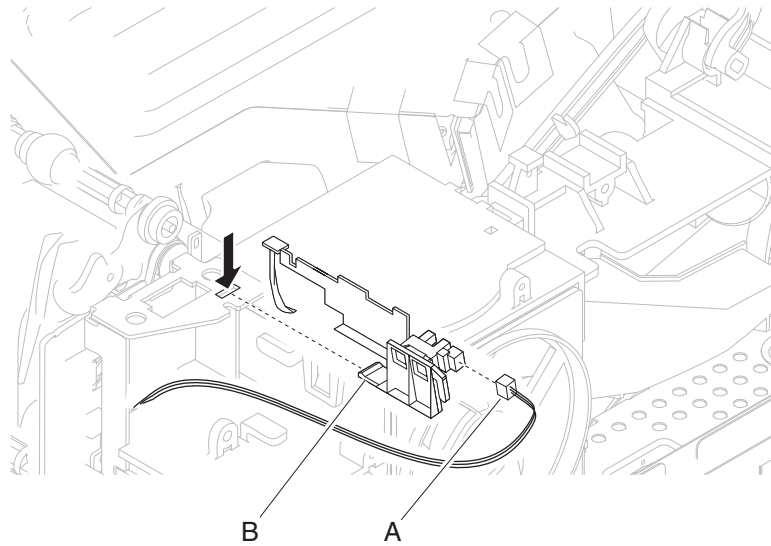

4. Remove the standard bin actuator assembly.

### Switch (media size) assembly removal (T650, T652, T654)

1. Remove the side cover, left. Go to **“MPF cam gear removal (T650, T652, T654)” on page 4-37** or **“Side cover, left removal (T652 and T654)” on page 4-66**.
2. Remove the six screws (A) securing the metal cover to the machine.

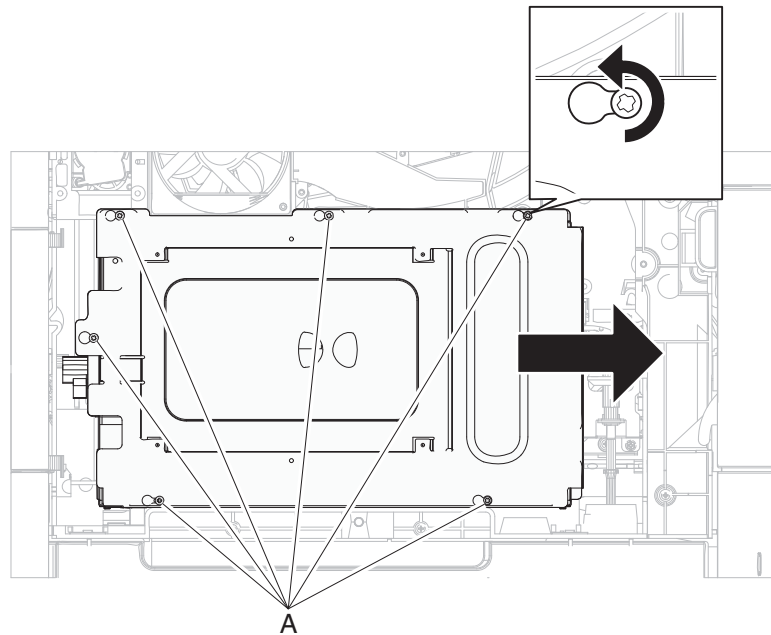

3. Remove the metal cover.
4. Remove the media tray.
5. Gently place the machine on the left of right side.



6. Release the two hooks (B) securing the switch (media size) assembly to the machine.

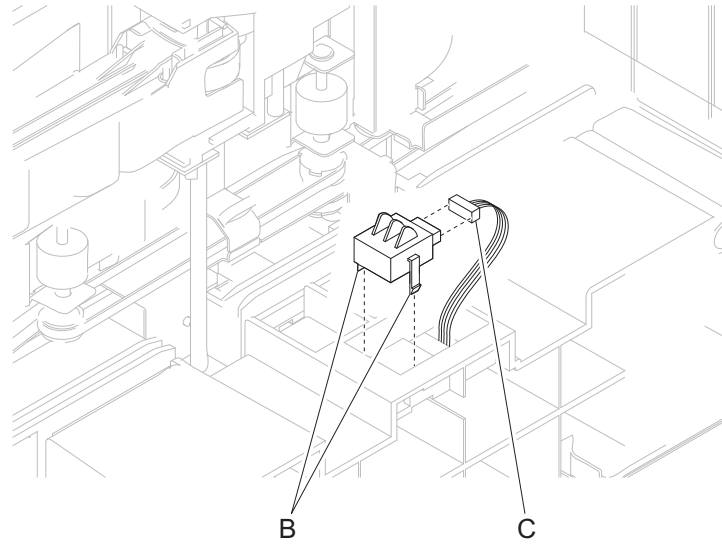

7. Remove the switch (media size) assembly.
8. Disconnect the connection (C) from the switch (media size) assembly.

## System card assembly removal (T650, T652, T654, T656)

**Warning:** When replacing any of the following components:

- Operator panel assembly
- System card assembly

Only replace one component at a time. Replace the required component and perform a POR before replacing a second component listed above. If this procedure is not followed, the printer will be rendered inoperable. Never replace two or more of the components listed above without a POR after installing each one or the printer will be rendered inoperable.

Never install and remove components listed above as a method of troubleshooting components. Once a component has been installed in a machine, it can not be used in another machine. It must be returned to the manufacturer.



### CAUTION

This product contains a lithium battery. THERE IS A RISK OF EXPLOSION IF THE BATTERY IS REPLACED BY AN INCORRECT TYPE. Discard used batteries according to the battery manufacturer's instructions and local regulations.

1. Remove the side cover, left. Go to **"MPF cam gear removal (T650, T652, T654)"** on page 4-37 or **"Side cover, left removal (T652 and T654)"** on page 4-66.
2. Remove the six screws (A) securing the metal shield to the machine.

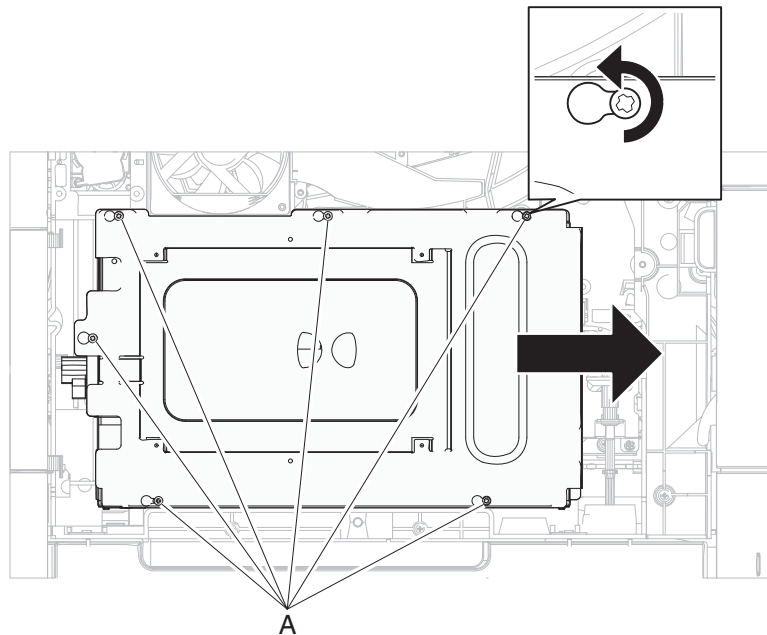

3. Slide the metal shield in the direction of the arrow.

4. Remove the metal shield.

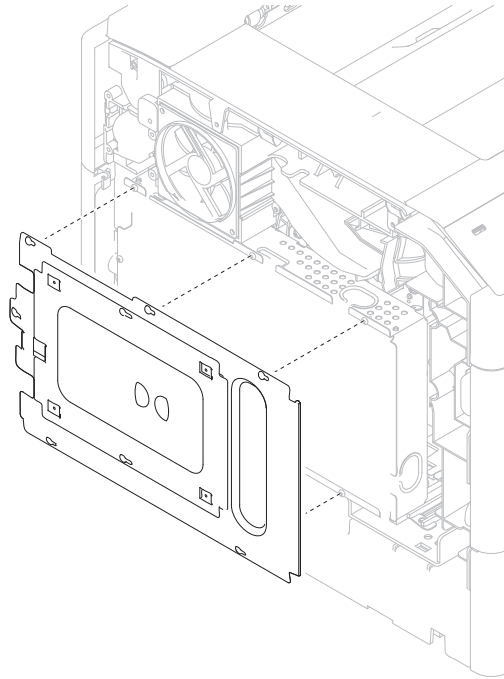

**WARNING:** When disconnecting all the electrical connections, ensure that the connectors and harnesses do not become damaged.

5. Disconnect all connections from the system card assembly.

**Note:** There are two fine thread screws and four coarse thread screws securing the system card assembly to the machine, ensure that these screws are properly reinstalled.

6. Remove the six screws (B) securing the system card assembly to the machine.

**WARNING:** When removing the system card assembly from the machine, ensure that the LVPS assembly connection (C) does not become damaged.

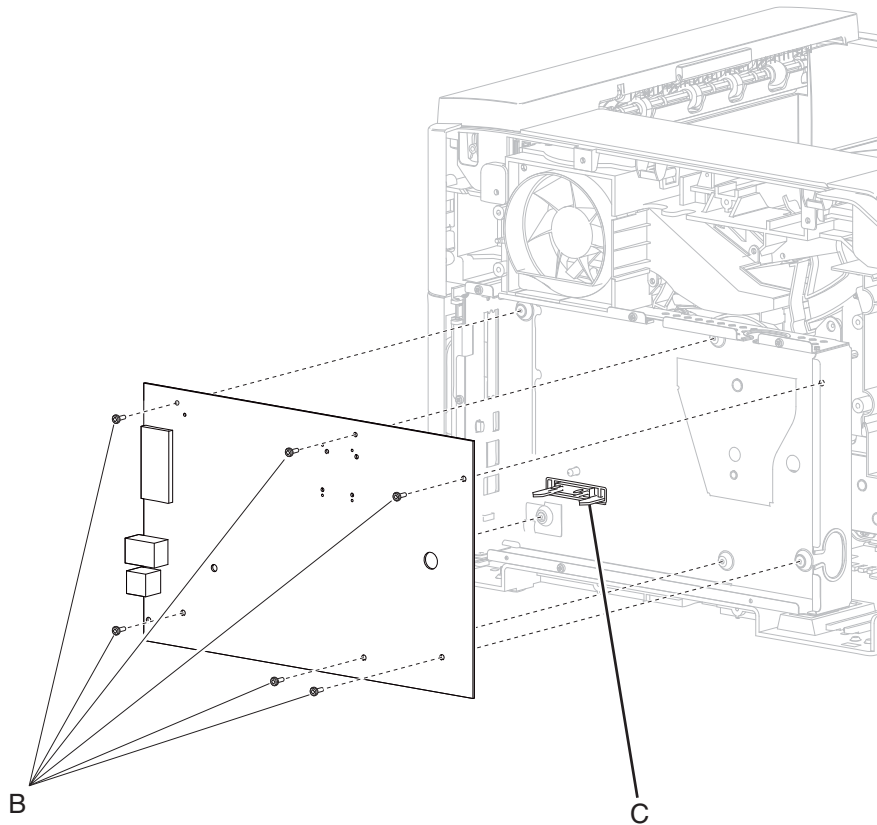

7. Remove the system card assembly.
8. Remove any remaining screws securing the system card assembly to the metal box.
9. Remove the system card assembly.

**Replacement Warning:** Ensure that all ground wires are properly replaced.

**Replacement Warning:** When replacing the system card assembly, ensure that the LVPS assembly connections (C) are properly aligned and inserted into the system card assembly, or damage will occur.

### Transfer roll assembly removal (T650, T652, T654)

1. Open the operator panel door assembly.
2. Remove the print cartridge.

3. Gently unsnap the transfer roll assembly from the machine.

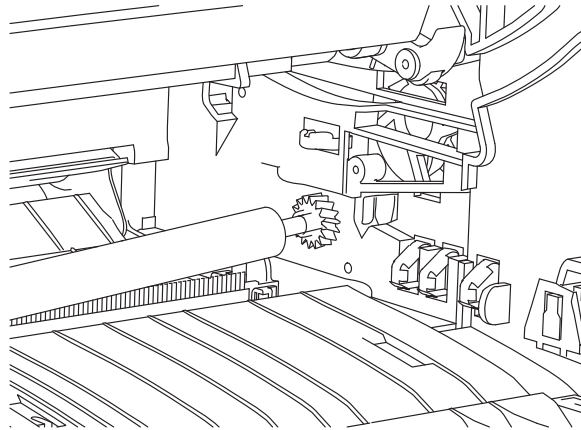

4. Remove the transfer roll assembly.

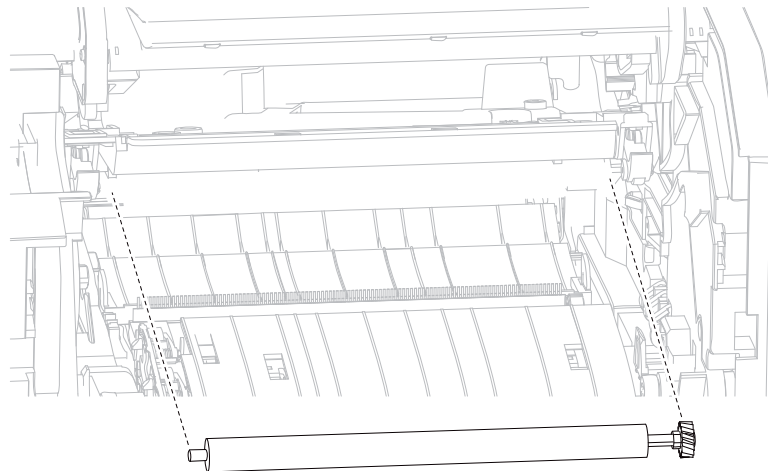

**Replacement Warning:** When replacing the transfer roll assembly, do not touch the foam surface.

### Transfer roll bracket assembly, left removal (T650, T652, T654)

1. Remove the transfer roll assembly. Go to **“Transfer roll assembly removal (T650, T652, T654)” on page 4-78.**
2. Remove the inner deflector. Go to **“Inner deflector removal (T650, T652, T654)” on page 4-25.**
3. Remove the screw (A) securing the transfer roll bracket assembly, left to the machine.
4. Remove the transfer roll bracket assembly, left.
5. Remove the roll clamp (B) from the transfer roll bracket assembly, left.
6. Remove the bushing (C).
7. Remove the spring (D).
8. Remove the screw (E).

- Remove the ground wire (F).

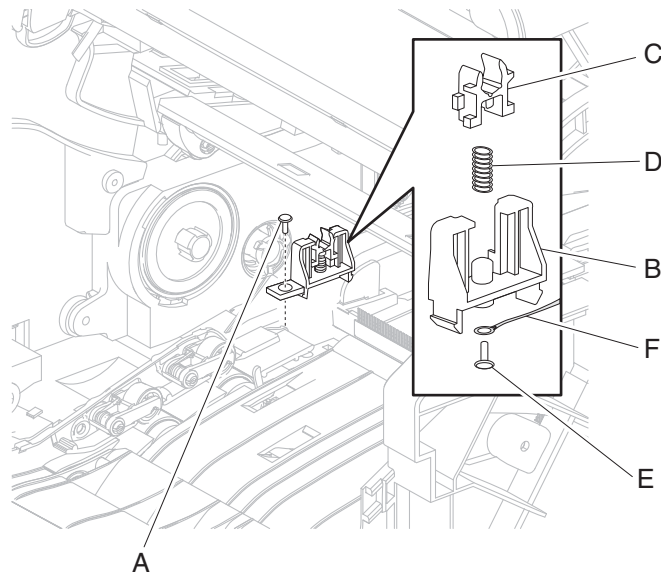

**Replacement Warning:** When reinstalling the transfer roll bracket assembly, left, ensure that the bushing (C), spring (D), and ground wire (F) are properly replaced.

### Transfer roll bracket assembly, right removal (T650, T652, T654)

- Remove the transfer roll assembly. Go to **“Transfer roll assembly removal (T650, T652, T654)” on page 4-78.**
- Remove the inner deflector. Go to **“Inner deflector removal (T650, T652, T654)” on page 4-25.**
- Remove the screw (A) securing the transfer roll bracket assembly, right to the machine.

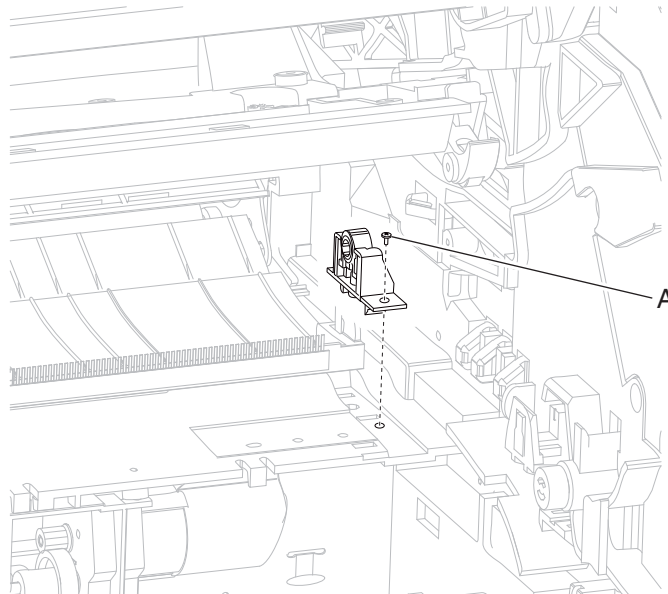

- Remove the transfer roll bracket assembly, right.

### Transfer deflector removal (T650, T652, T654)

- Remove the transfer roll assembly. Go to **“Transfer roll assembly removal (T650, T652, T654)” on page 4-78.**

2. Gently unsnap the transfer deflector from the machine.
3. Remove the transfer deflector.
4. Remove the screw (A) securing the ground wire to the transfer deflector.

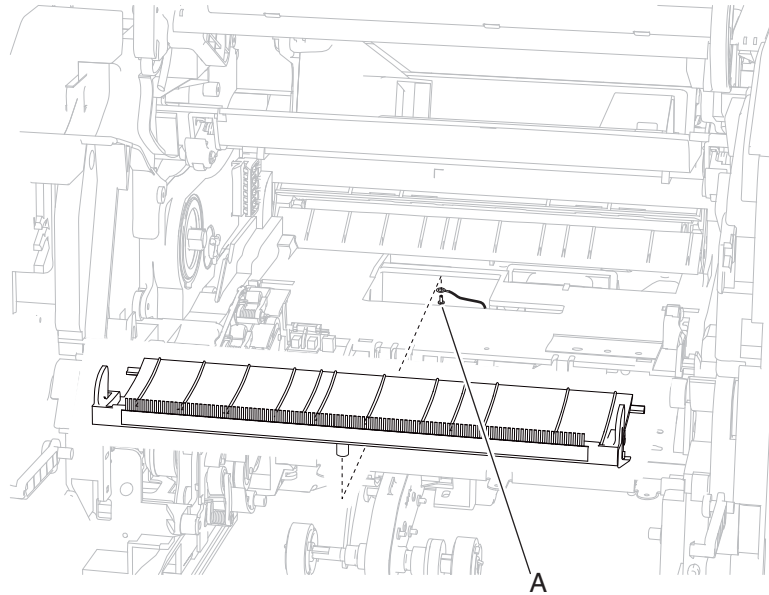

5. Remove the ground wire.

**Replacement Warning:** When replacing the transfer deflector, ensure that the ground wire is properly replaced.

### Tray roller catch assembly removal (T650, T652, T654)

1. Remove the media tray.
2. Remove the HVPS card assembly. Go to **"HVPS card assembly removal (T650, T652, T654)"** on **page 4-24**.
3. Release the spring from the machine.

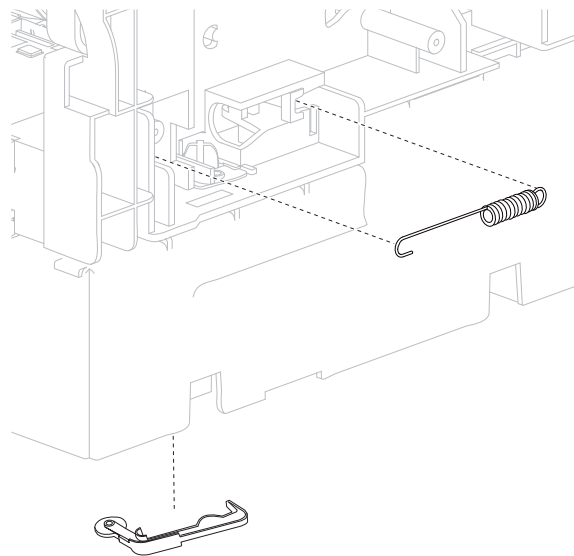

**Note:** The tray roller catch assembly should be removed from the media tray cabinet.

4. Remove the tray roller catch assembly from the machine.



---

## Option removals

## 5-bin mailbox rear door assembly removal

1. Open the rear door assembly and twist the rear door strap vertical and remove the strap.

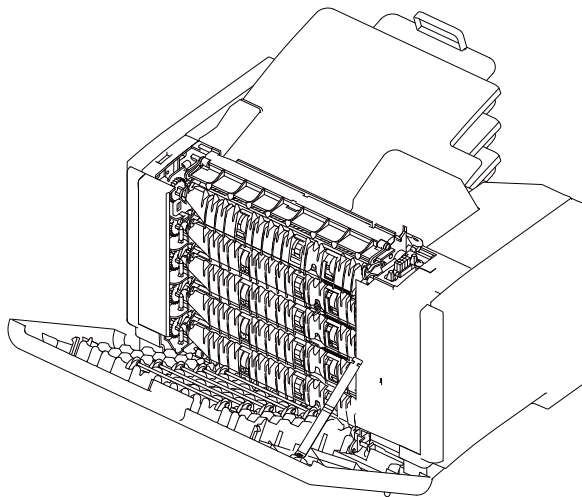

2. Pry the rear door hinges out of the bottom hinges and remove.

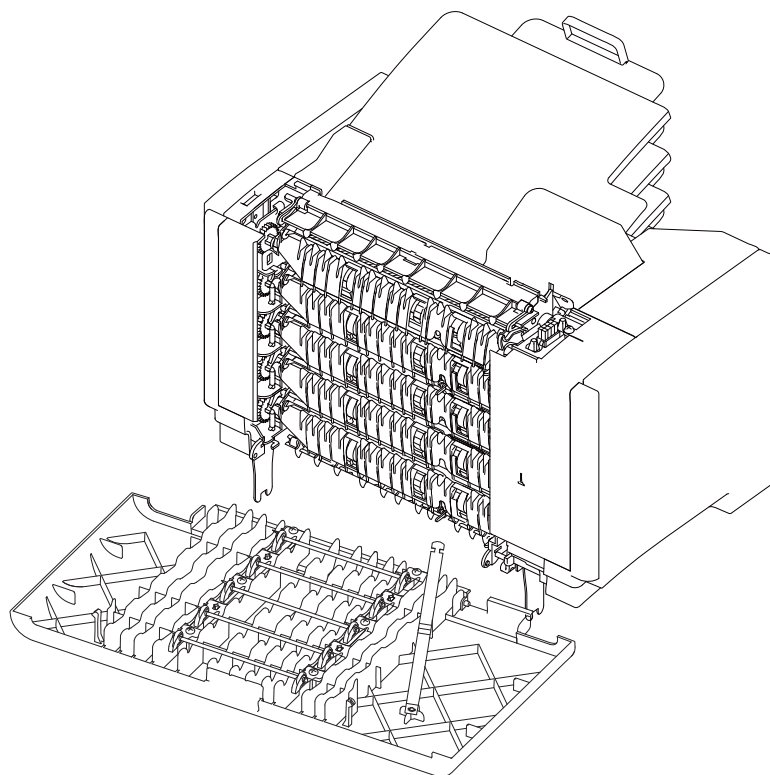

## 5-bin mailbox left outer cover removal

1. Open the rear door assembly.
2. Grasp the upper rear corner of the left outer cover and pull it off the 5-bin mailbox assembly.

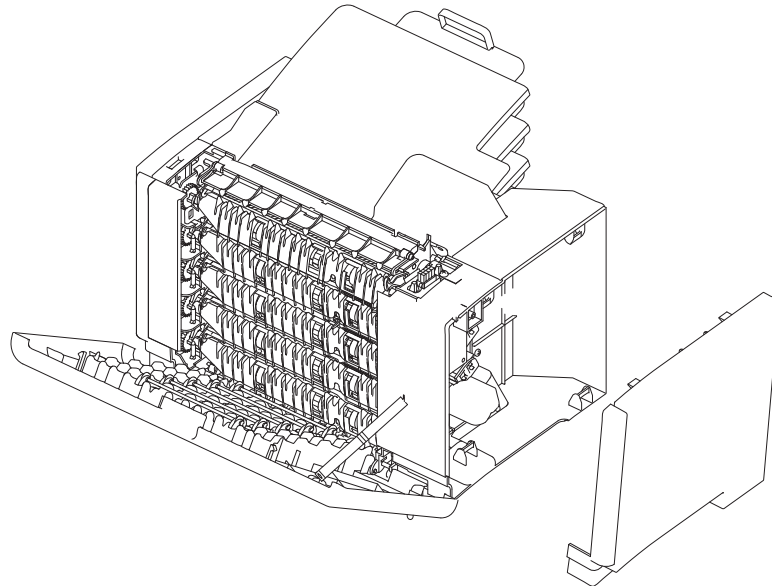

## 5-bin mailbox left inner cover removal

1. Remove the 5-bin mailbox rear door assembly. Go to **“5-bin mailbox rear door assembly removal” on page 4-84.**
2. Remove the 5-bin mailbox left outer cover. Go to **“5-bin mailbox left outer cover removal” on page 4-85.**

3. Remove the single screw (A) on the top and the four screws (B) on the inside of the left inner cover.

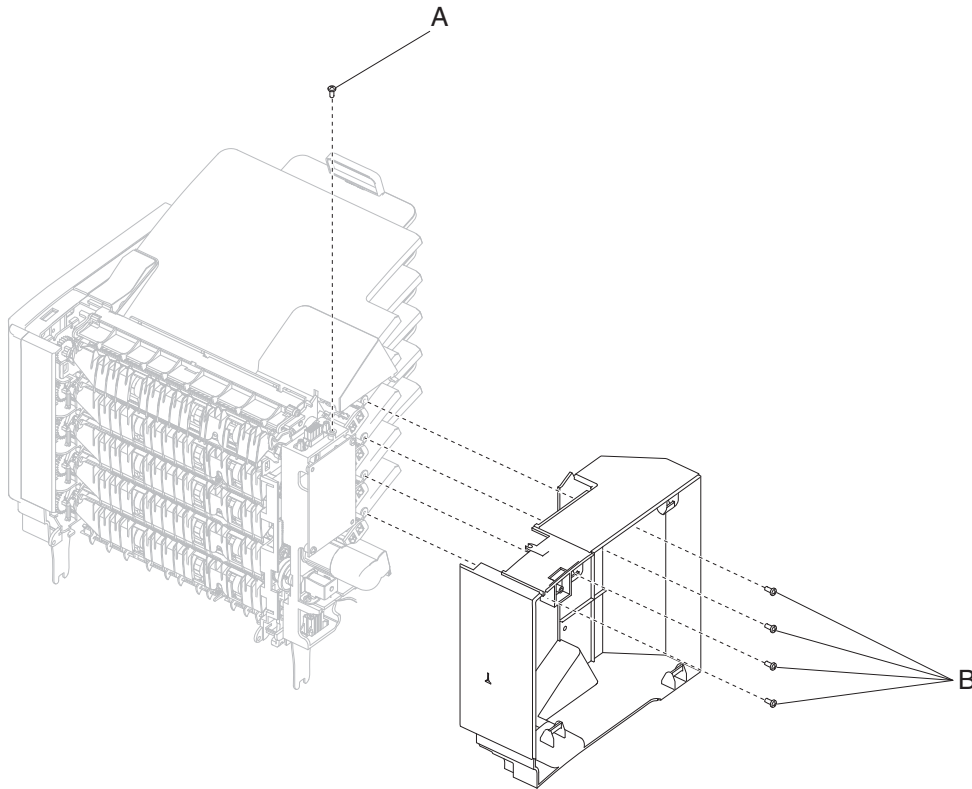

4. Remove the 5-bin mailbox left inner cover.

### 5-bin mailbox right outer cover removal

1. Open the rear door assembly.
2. Grasp the upper rear corner of the right outer cover and pull it off the 5-bin mailbox assembly.

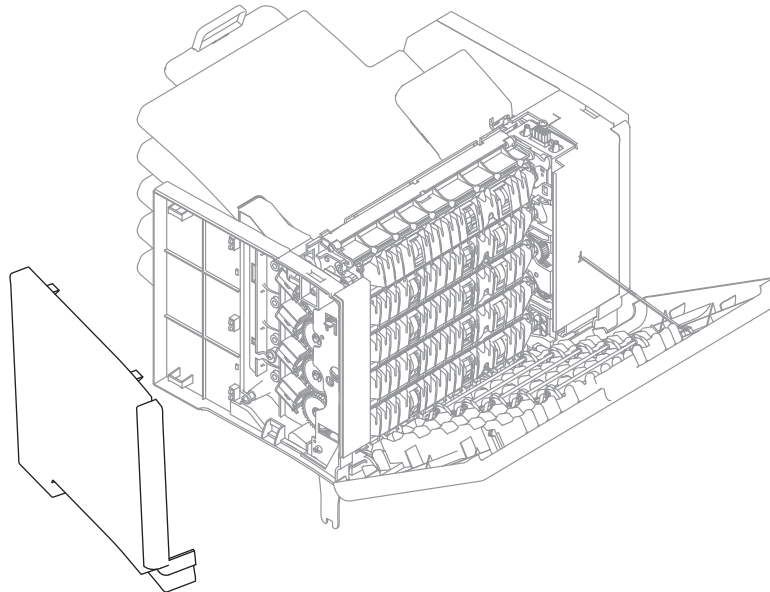

## 5-bin mailbox right inner cover removal

1. Remove the 5-bin mailbox rear door assembly. Go to **“5-bin mailbox rear door assembly removal”** on **page 4-84**.
2. Remove the 5-bin mailbox right outer cover. Go to **“5-bin mailbox right outer cover removal”** on **page 4-86**.
3. Remove the three screws (A) securing the right inner cover to the 5-bin mailbox assembly.

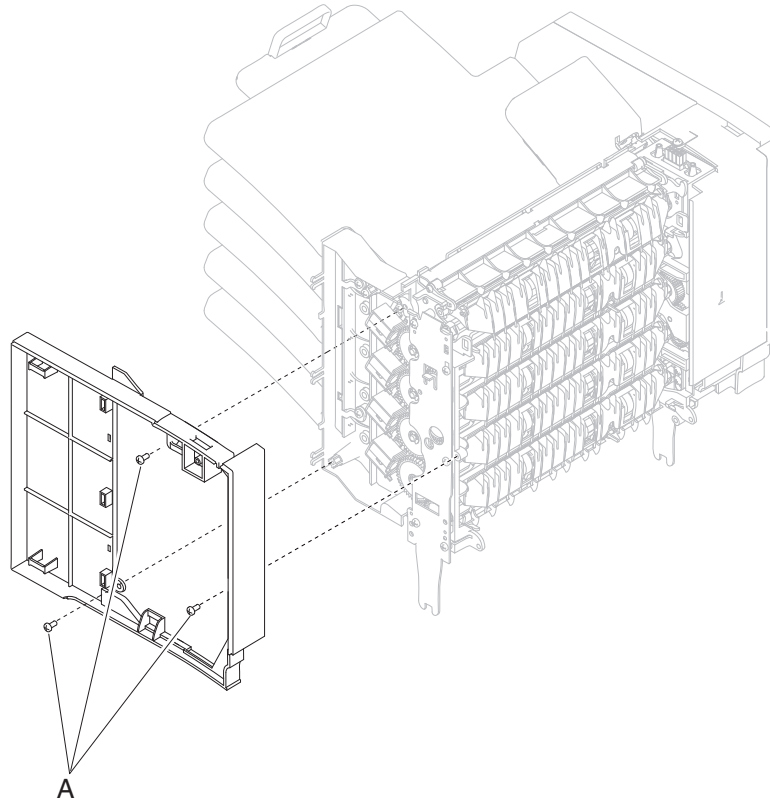

4. Remove the 5-bin mailbox right inner cover.

## 5-bin mailbox top cover removal

1. Open the rear door assembly.
2. Remove the cable cover panel by lifting up on the right side and pull to the right and out.

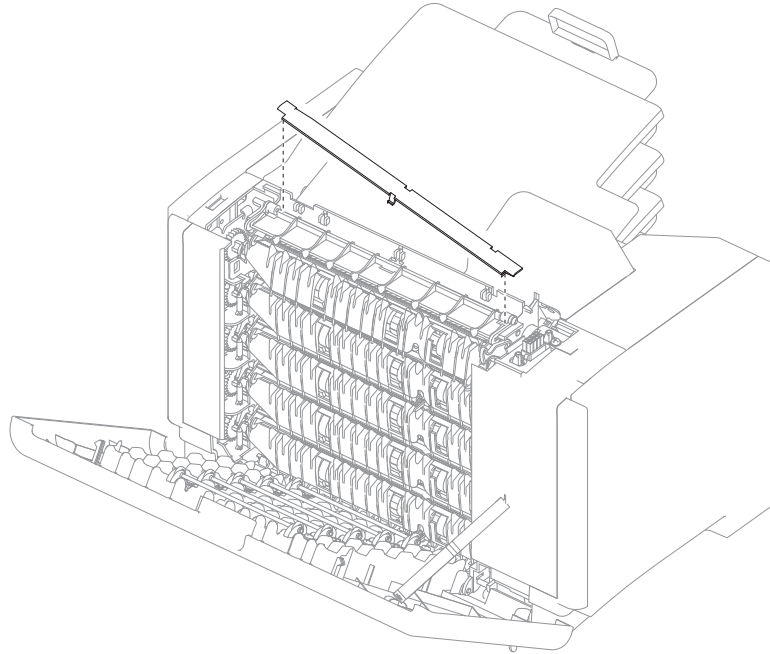

3. Remove the two screws (A) on each side of the top cover.

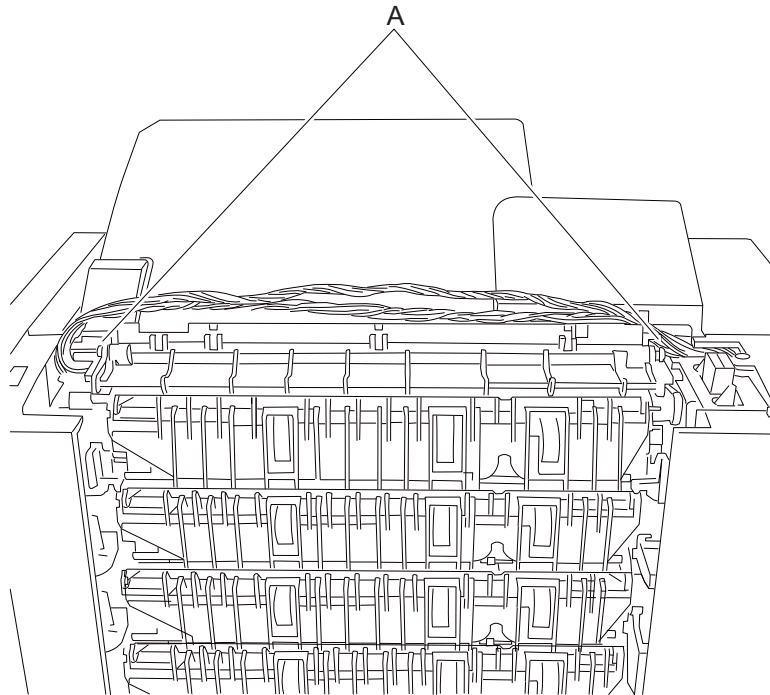

4. Pull the left side up first and carefully unroute the cables from the channels and then remove the top cover.



## 5-bin mailbox sensor (pass through) removal

1. Remove the 5-bin mailbox left outer cover. Go to **“5-bin mailbox left outer cover removal” on page 4-85.**
2. If the lower pass through sensor needs to be removed, first remove the 5-bin mailbox rear door assembly. Go to **“5-bin mailbox rear door assembly removal” on page 4-84.**
3. Lift up the deflector gate above the sensor (pass through) and using a flat-blade screwdriver, release the tabs securing the sensor.

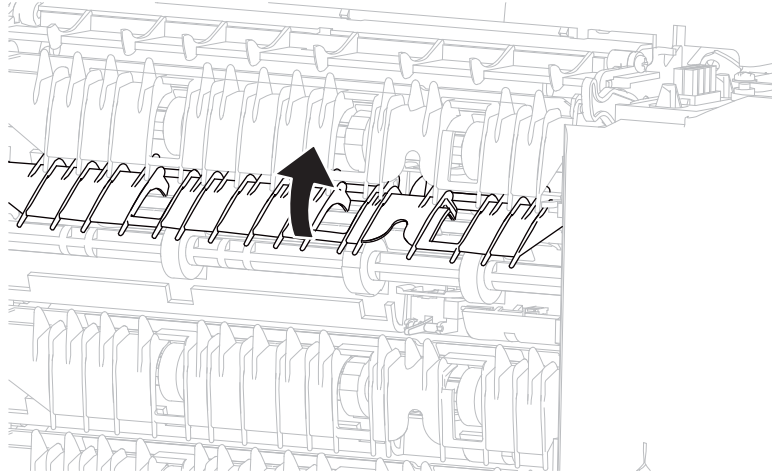

4. Disconnect the appropriate harness from the controller card (J11) for the upper sensor (pass through) and (J5) for the lower sensor (pass through).

**Note:** The use of a spring hook facilitates the unrouting of the cables. Remove the two screws (A) and lift the left frame assembly to ease removal of the lower sensor (pass through) harness.

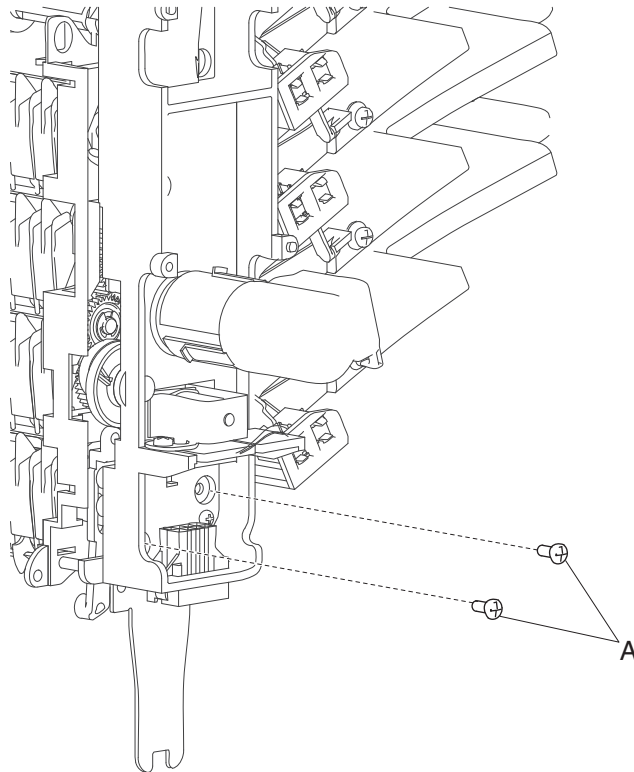



## 5-bin mailbox sensor (media bin empty) removal

1. Remove the 5-bin mailbox left outer cover. Go to **“5-bin mailbox left outer cover removal”** on page 4-85.
2. Release the connecting tabs on the sensor (media bin empty) and remove from its bracket.

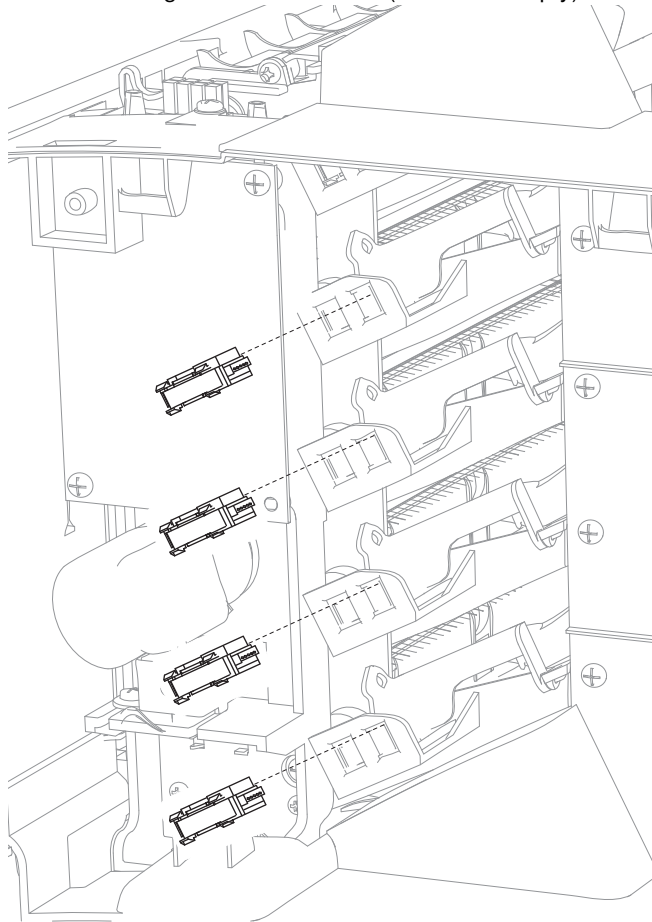

3. Disconnect the harness from the sensor (media bin empty).

## 5-bin mailbox controller card assembly removal

1. Remove the 5-bin mailbox left outer cover. Go to **“5-bin mailbox left outer cover removal”** on page 4-85.
2. Disconnect all the harnesses from the 5-bin mailbox controller card assembly.
3. Remove the two screws (A) securing the controller card assembly to the 5-bin mailbox assembly.

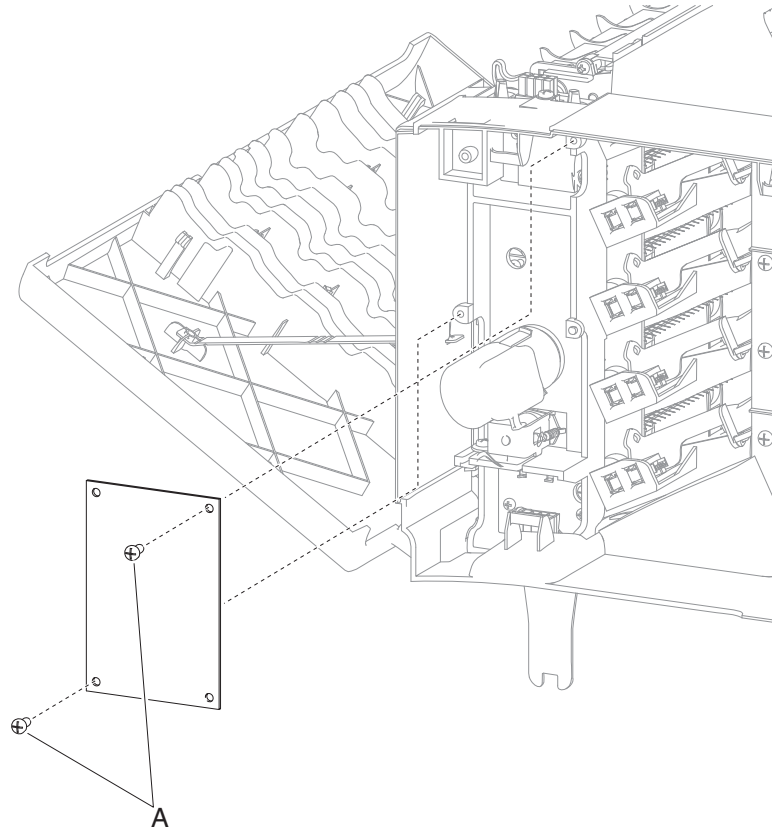

4. Remove the 5-bin mailbox controller card assembly.

## 5-bin mailbox static brush mylar assembly removal

1. Remove the 5-bin mailbox top cover. Go to **“5-bin mailbox top cover removal”** on page 4-88.
2. Carefully flex the 5-bin mailbox static brush mylar assembly to detach the hinges on each side.
3. Remove the 5-bin mailbox static brush mylar assembly.

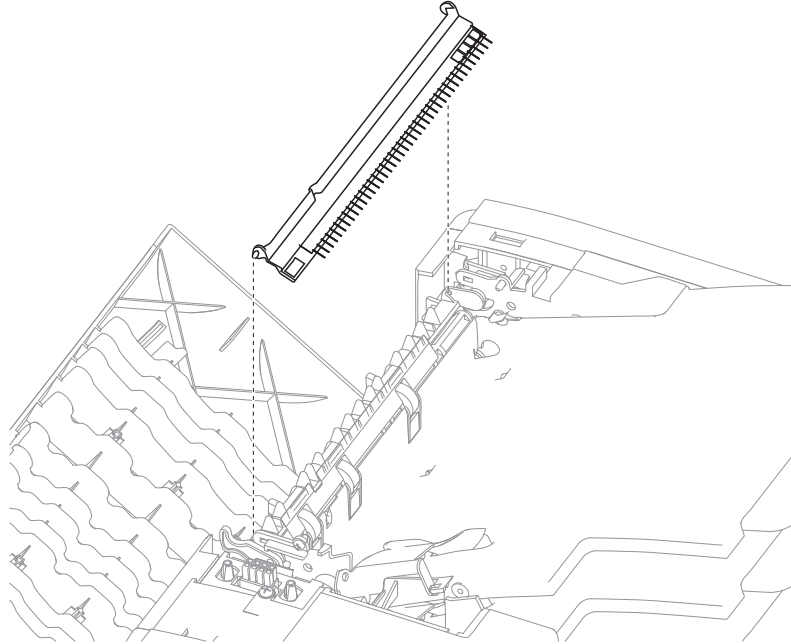

## 5-bin mailbox media bin fifth deflector removal

1. Remove the rear door assembly. Go to **“5-bin mailbox rear door assembly removal” on page 4-84.**
2. With a spring hook, carefully remove the upper deflector gate spring and for ease of reassembly, temporarily
3. Temporarily hook the spring to the upper frame tab.

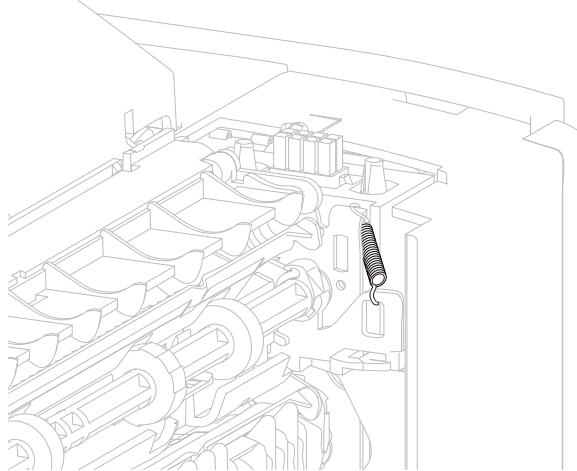

4. Unsnap each side of the deflector gate and remove.

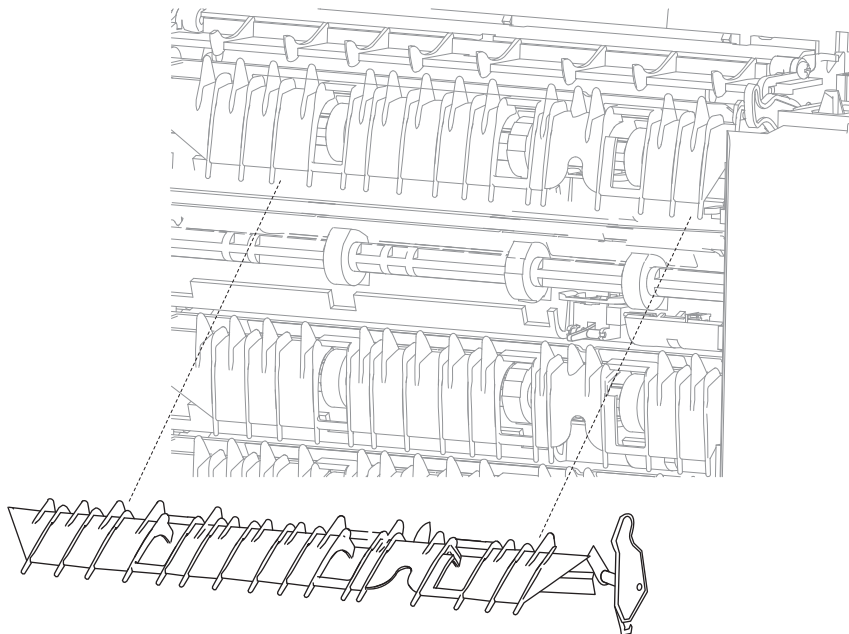

**Replacement Note:** The static brush mylar assembly is attached to the media bin fifth deflector. Do not forget to reinstall it on the new deflector.

## 5-bin mailbox media bin first through fourth deflector removal

1. Remove the rear door assembly. Go to **“5-bin mailbox rear door assembly removal”** on page 4-84.
2. Using a springhook, remove the deflector spring from the deflector.

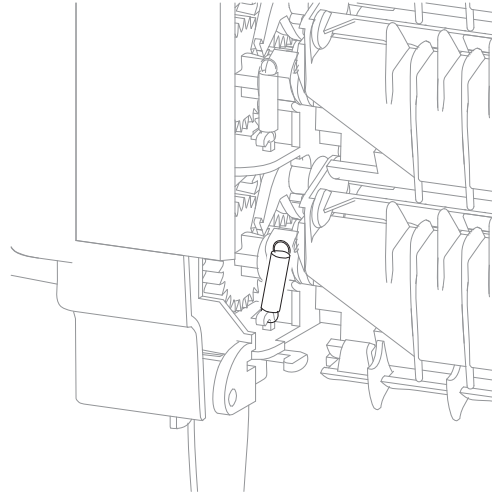

3. Unsnap each side of the deflector and remove.

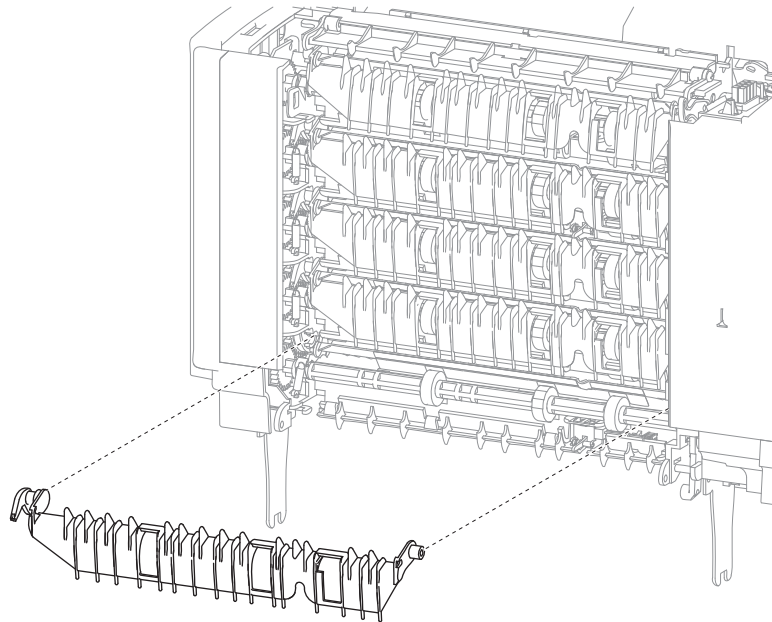

**Replacement Note:** The static brush mylar assembly is attached to the media bin fifth deflector. Do not forget to reinstall it on the new deflector.

## 5-bin mailbox media bin extension assembly removal

1. Fully extend the media bin extension.
2. Release the two tabs on the underside of the extension and pull out the rest of the way.

## 5-bin mailbox deflector gate solenoid removal

1. Remove the 5-bin mailbox right outer cover. Go to **“5-bin mailbox right outer cover removal” on page 4-86.**
2. Remove the 5-bin mailbox left outer cover. Go to **“5-bin mailbox left outer cover removal” on page 4-85.**
3. Remove the top cable cover panel.

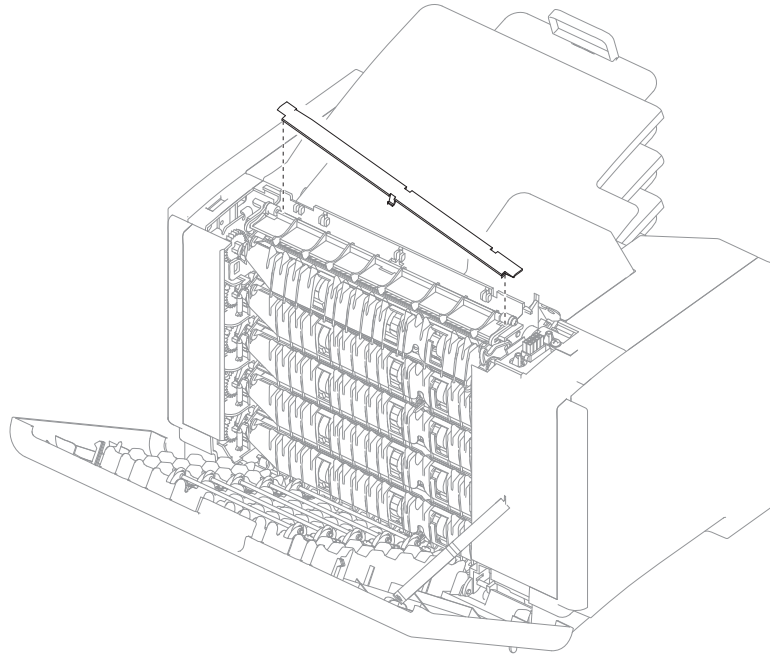

4. Remove the screw (A) securing the appropriate 5-bin mailbox deflector gate solenoid.

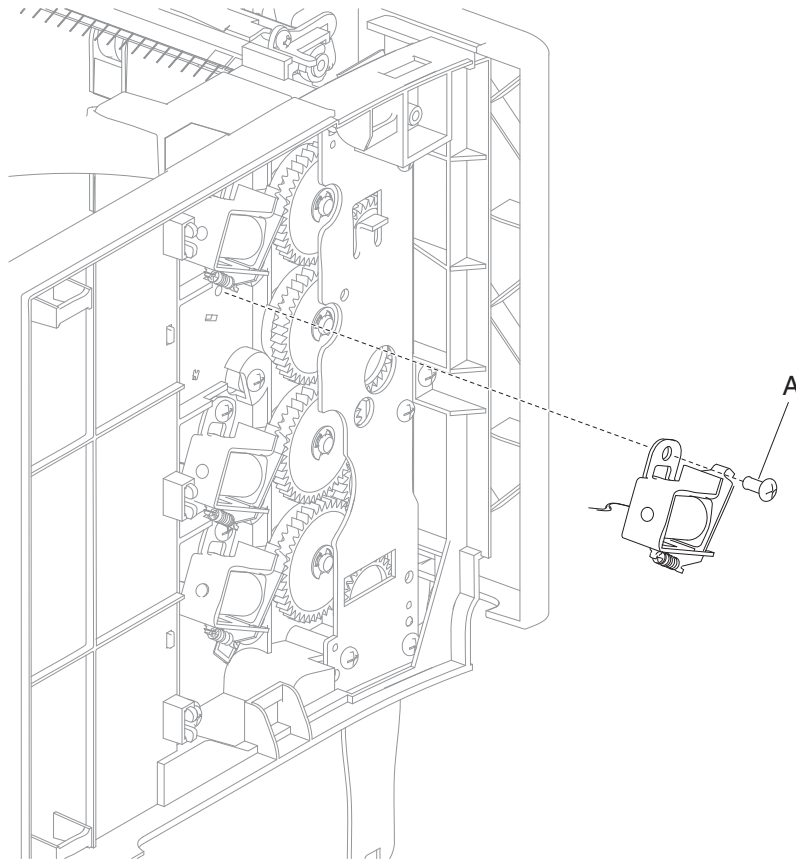

5. Remove and unroute the cable to the deflector gate solenoid.
  6. Disconnect the proper deflector gate solenoid harness from the controller card.
- Note:** To ease the cable unrouting, cut the appropriate cable.

## 5-bin mailbox transport solenoid removal

1. Remove the 5-bin mailbox left outer cover. Go to **“5-bin mailbox left outer cover removal”** on page 4-85.
2. Disconnect J15 at the controller card.
3. Remove the screw (A) securing the 5-bin mailbox transport solenoid to the left frame.

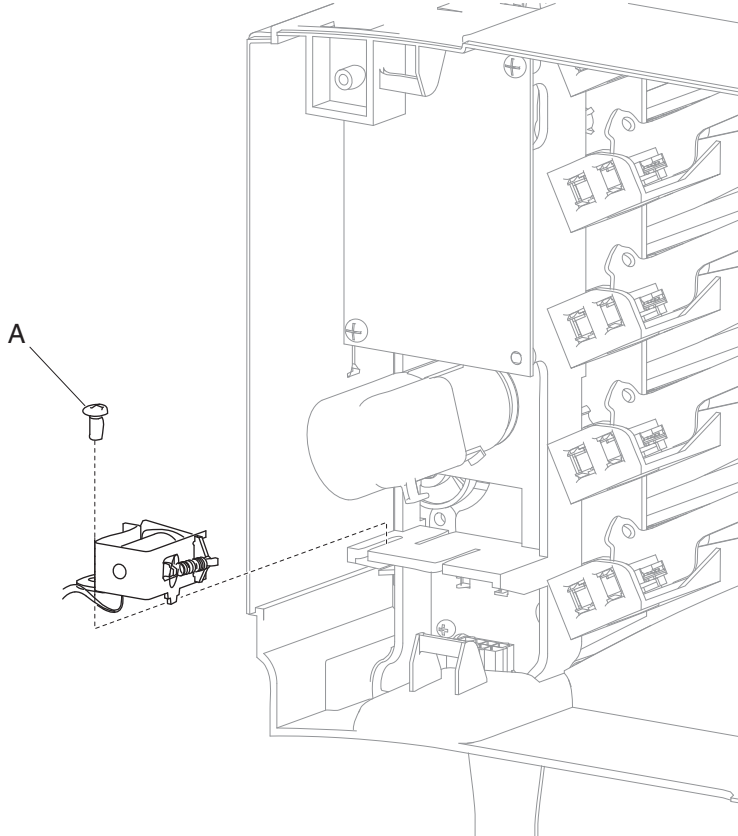

4. Remove the 5-bin mailbox transport solenoid.



## 5-bin mailbox sensor (deflector gate HP) removal

1. Remove the 5-bin left inner cover. Go to **“5-bin mailbox left inner cover removal”** on page 4-85.
2. Remove the following harnesses from the controller card: J14 A and B, J2, and J11.
3. Remove the two screws (A) securing the controller card assembly and move the card to the side.

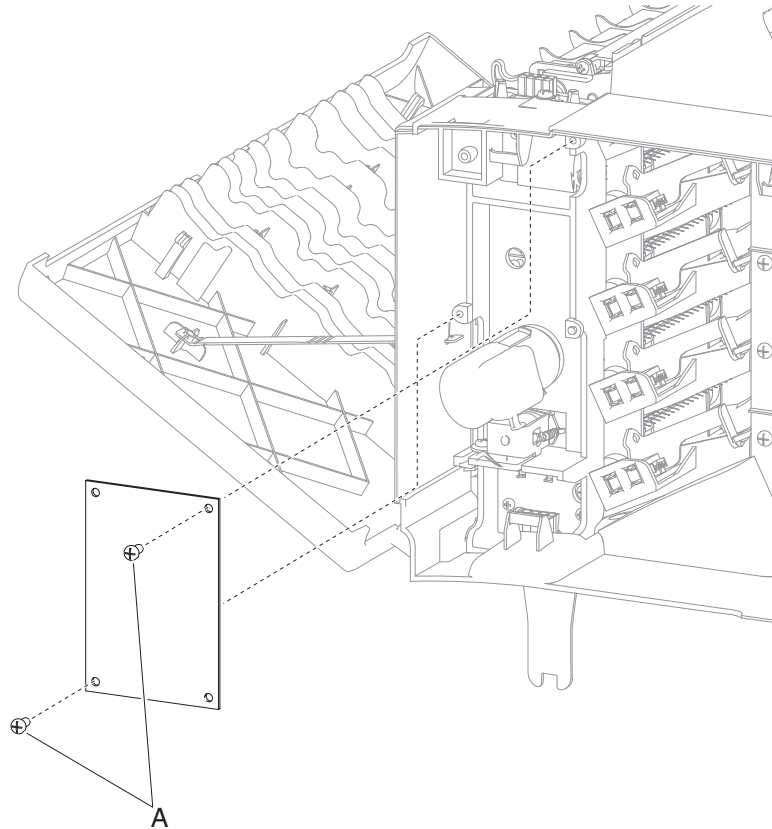

4. Remove the four screws (B) securing the left frame assembly to the 5-bin mailbox assembly.

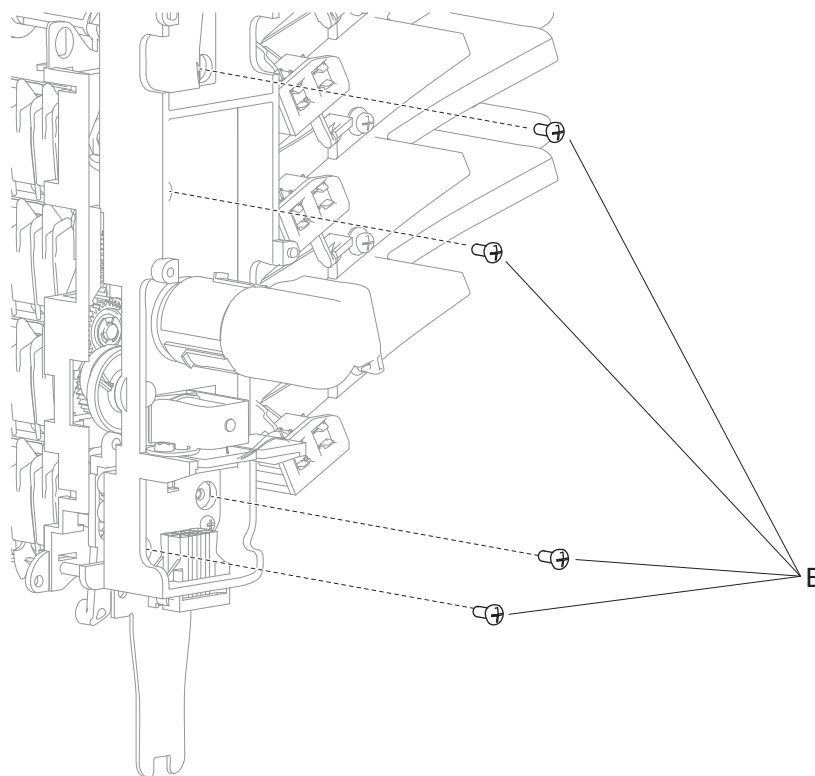

5. Move the left frame assembly out of the way.
6. Remove the 5-bin mailbox sensor (deflector gate HP) by pressing the tabs.

7. Disconnect the harness from the 5-bin mailbox sensor (deflector gate HP).

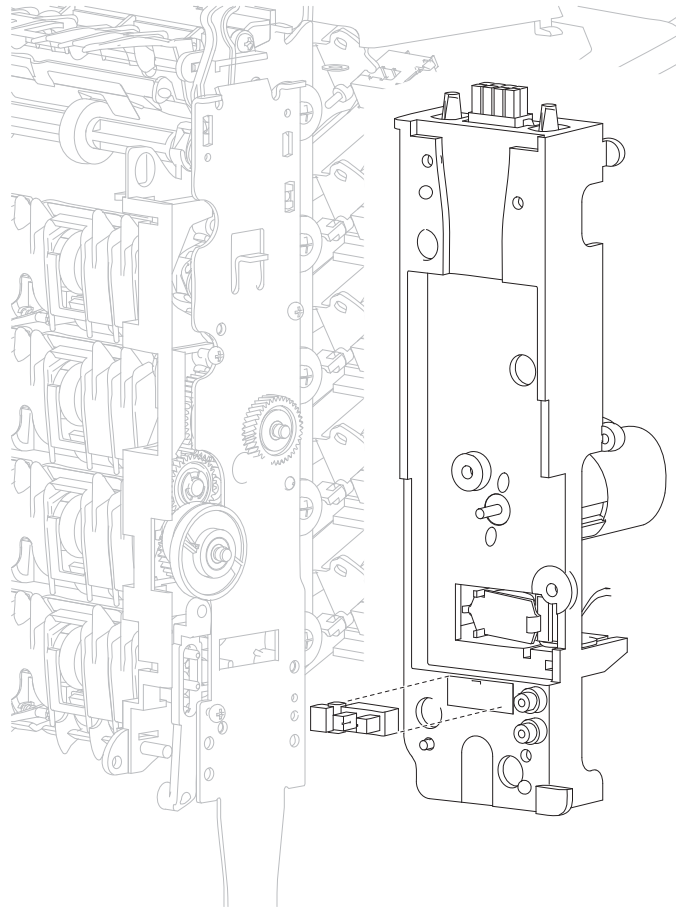

### 250-sheet option tray assembly

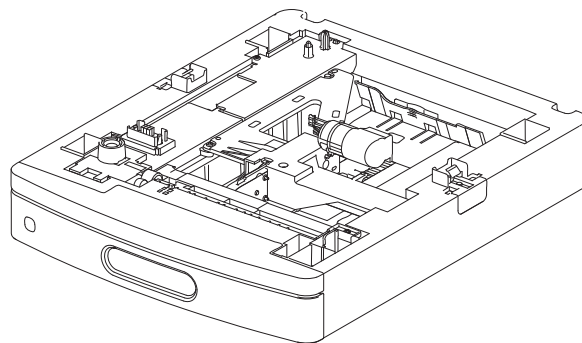

**Note:** Carefully remove the base machine from the input option tray assembly before proceeding.

### 250-sheet media tray assembly removal

**Note:** This removal procedure can be applied to 250-sheet option drawer assembly.

Remove the 250-sheet media tray assembly from the 250-sheet option drawer assembly.

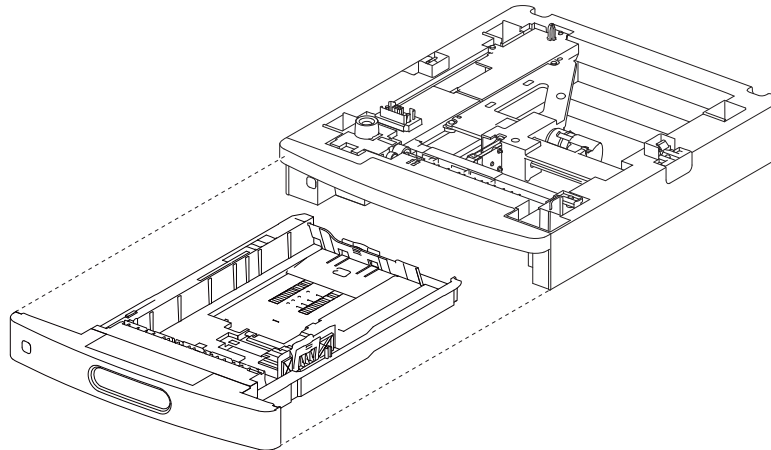

### 250-sheet pick arm bracket assembly removal

**Note:** Carefully remove the base machine from the input option tray assembly before proceeding.

1. Disconnect the two 250-sheet pick arm bracket assembly cable connectors from the 250-sheet controller card assembly.
2. Detach the pick arm spring from the drawer.

3. Remove the three screws (A) securing the 250-sheet pick arm bracket assembly to the drawer.

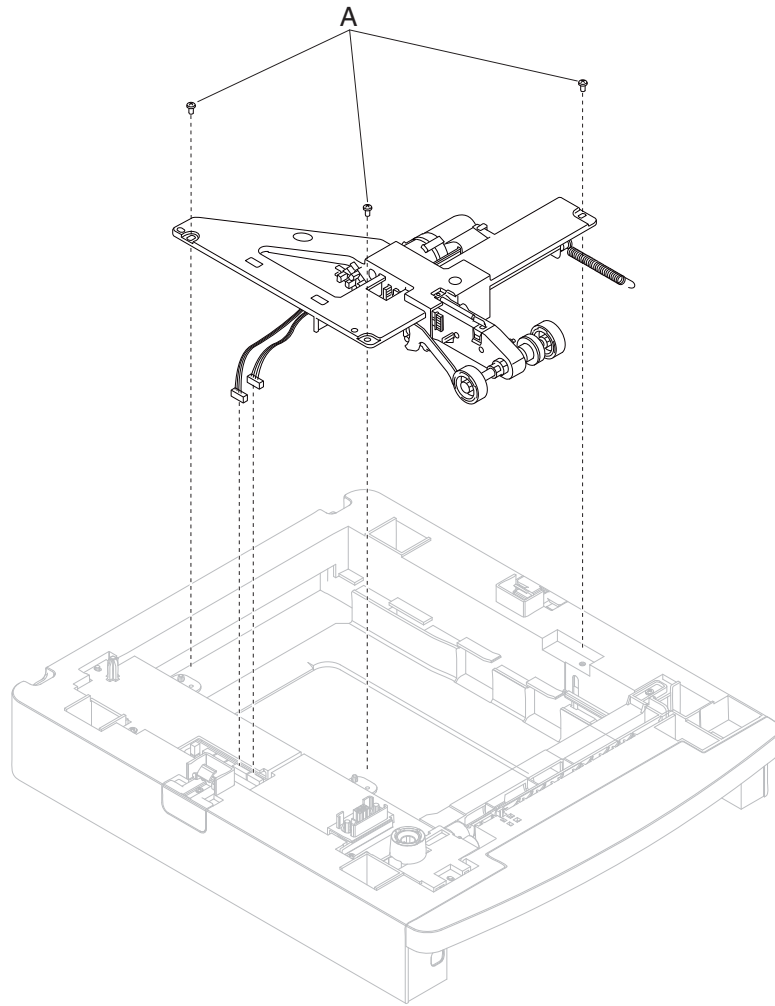

4. Remove the 250-sheet pick arm bracket assembly.

## 250-sheet media out actuator removal

**Note:** Carefully remove the base machine from the input option tray assembly before proceeding.

1. Remove the 250-sheet pick arm bracket assembly. Go to **“250-sheet pick arm bracket assembly removal” on page 4-102.**
2. Release the hook (A) securing the 250-sheet media out actuator to the 250-sheet pick arm bracket assembly.

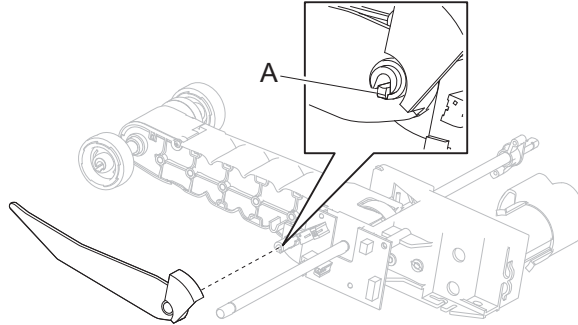

3. Remove the 250-sheet media out actuator from the drawer.

## 250-sheet frame assembly removal

**Note:** The 250-sheet frame assembly is not a FRU.

1. Remove the 250-sheet pick arm bracket assembly. Go to **“250-sheet pick arm bracket assembly removal” on page 4-102**
2. Release the hooks securing the sensor (pass through) to the drawer.
3. Remove the sensor (pass through) from the drawer.

4. Remove the four screws (A) securing the 250-sheet frame assembly to the drawer.

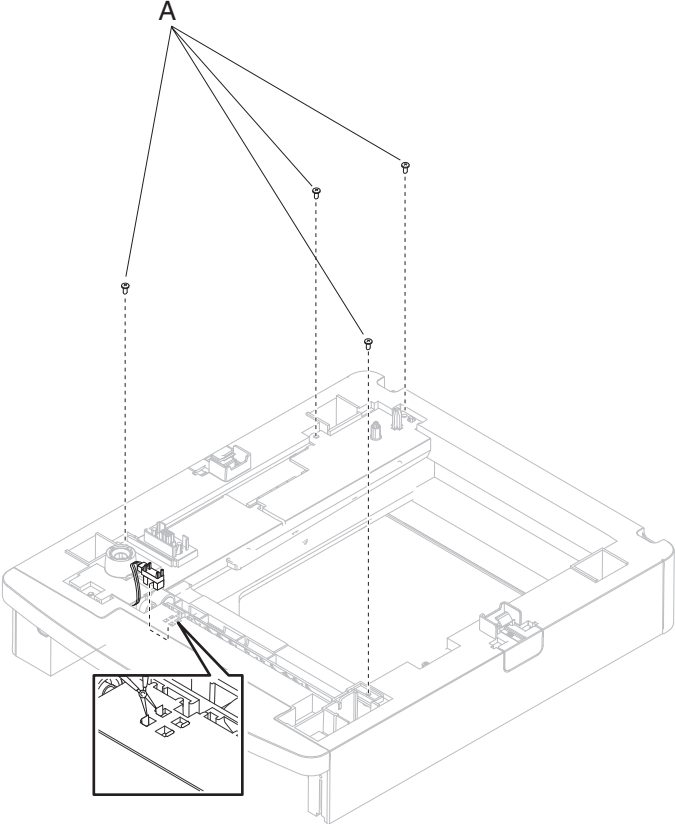

5. Remove the 250-sheet frame assembly.

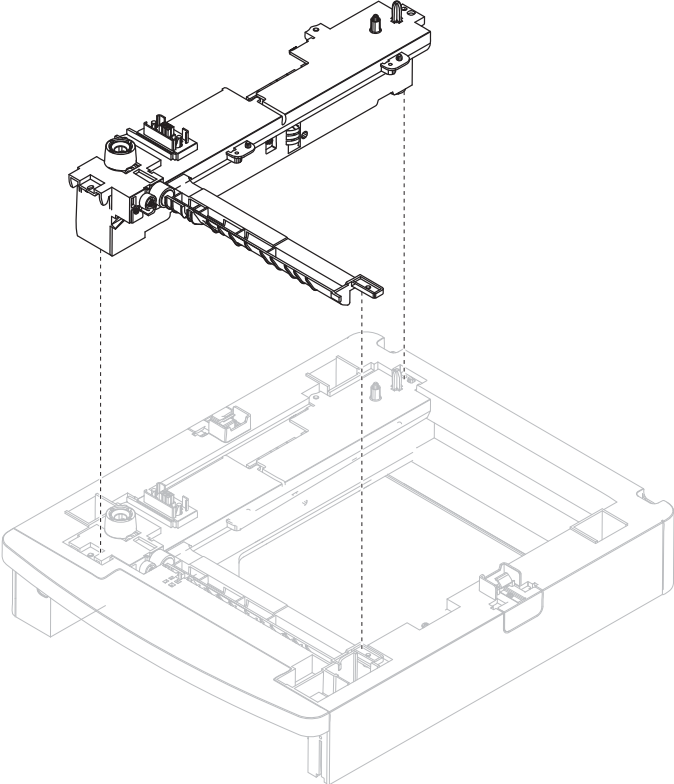

## 250-sheet controller card assembly removal

1. Remove the 250-sheet frame assembly. Go to **“250-sheet frame assembly removal”** on page 4-104.
2. Disconnect the three connectors from the 250-sheet controller card assembly.

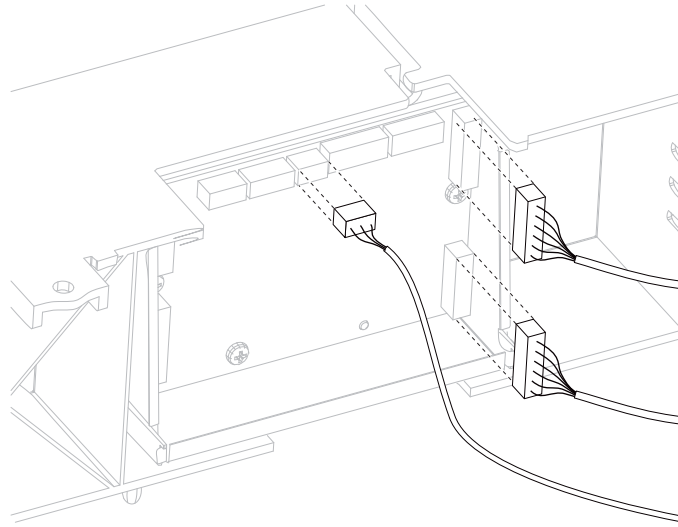

3. Remove the three screws (B) securing the 250-sheet controller card assembly to the 250-sheet frame.

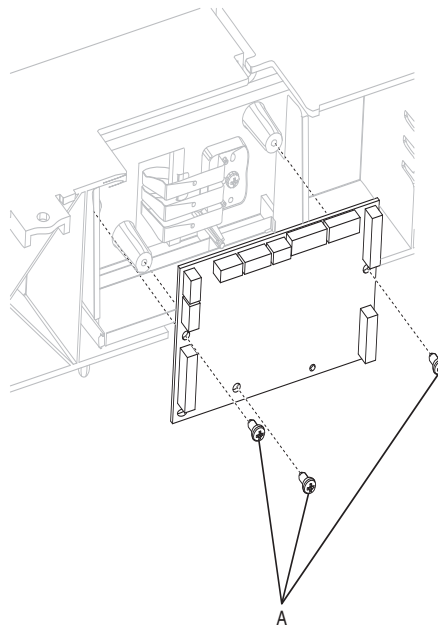

4. Remove the 250-sheet controller card assembly.



## 550-sheet option tray assembly

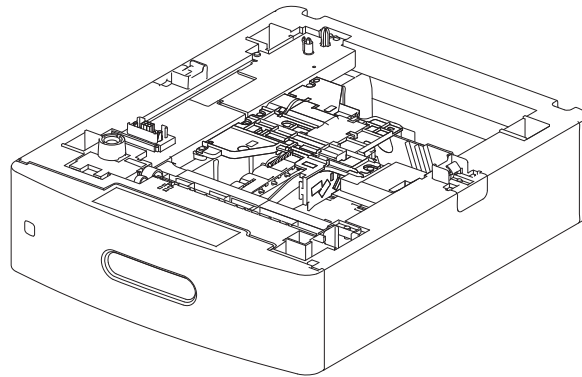

**Note:** Carefully remove the base machine from the input option tray assembly before proceeding.

## 550-sheet media tray assembly removal

**Note:** This removal procedure can be applied to 550-sheet option drawer assembly.

Remove the 550-sheet media tray assembly from the 550-sheet option drawer assembly.

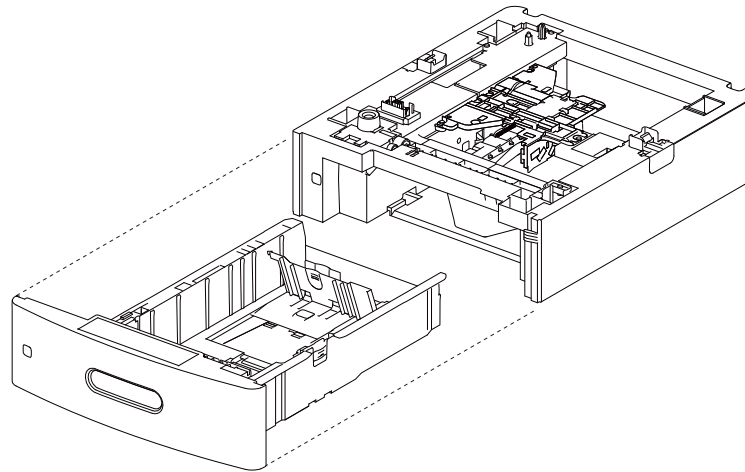

## 550-sheet pick arm bracket assembly removal

1. Remove the 550-sheet media tray assembly. Go to **“Media out actuator removal (models T652 and T654)” on page 4-158.**
2. Remove the two 550-sheet pick arm bracket assembly cable connectors (A) from the 550-sheet controller card assembly.
3. Detach the 550-sheet bellcrank recoil spring (B) from the drawer.
4. Remove the four screws (C) securing the 550-sheet pick arm bracket assembly to the drawer.

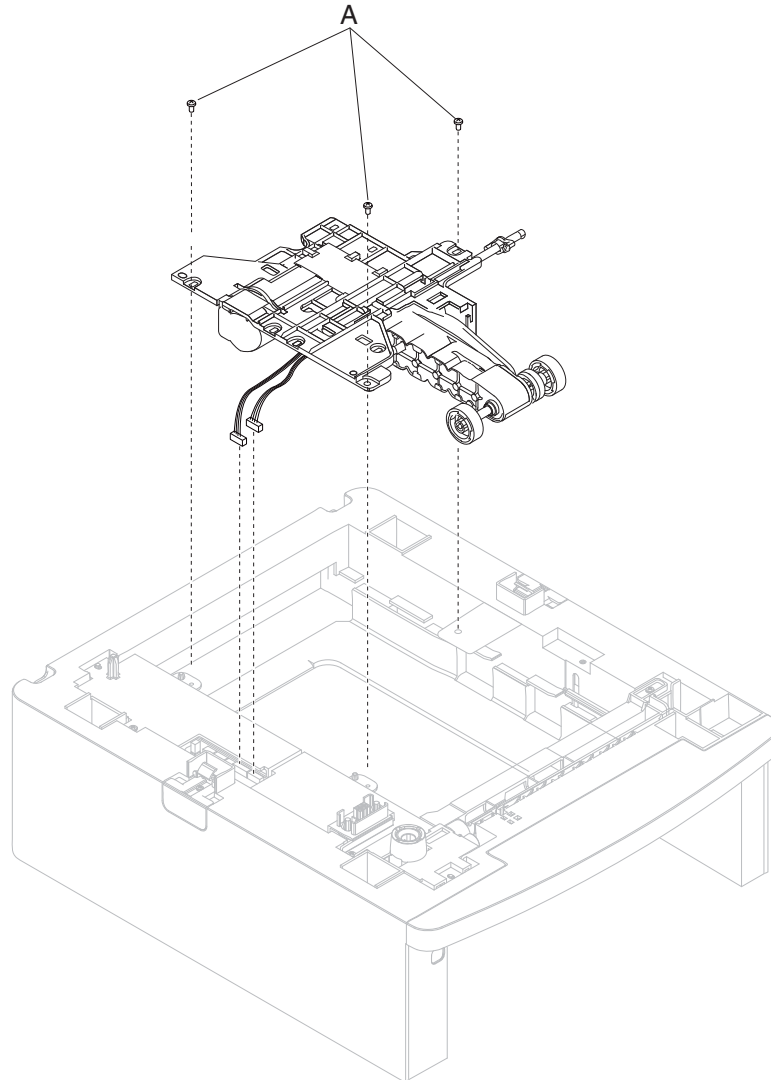

5. Remove the 550-sheet pick arm bracket assembly.

## 550-sheet bellcrank recoil spring removal

1. Remove the 550-sheet pick arm bracket assembly. Go to **“550-sheet pick arm bracket assembly removal” on page 4-108.**
2. Remove the 550-sheet bellcrank recoil spring from the 550-sheet pick arm bracket assembly.

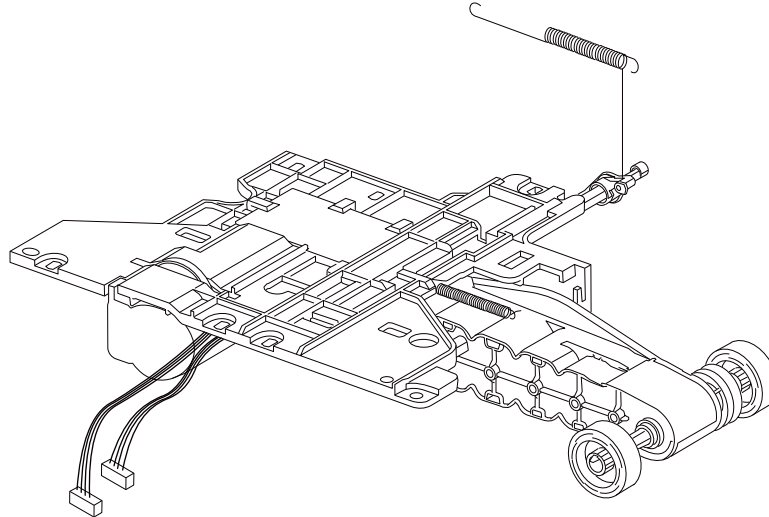

## 550-sheet frame assembly removal

**Note:** The 550-sheet frame assembly is not a FRU.

1. Remove the 550-sheet pick arm bracket assembly. Go to **“550-sheet pick arm bracket assembly removal” on page 4-108.**
2. Release the hooks securing the sensor (pass through) to the drawer.
3. Remove the sensor (pass through) from the drawer.

4. Remove the four screws (A) securing the 550-sheet frame assembly to the drawer.

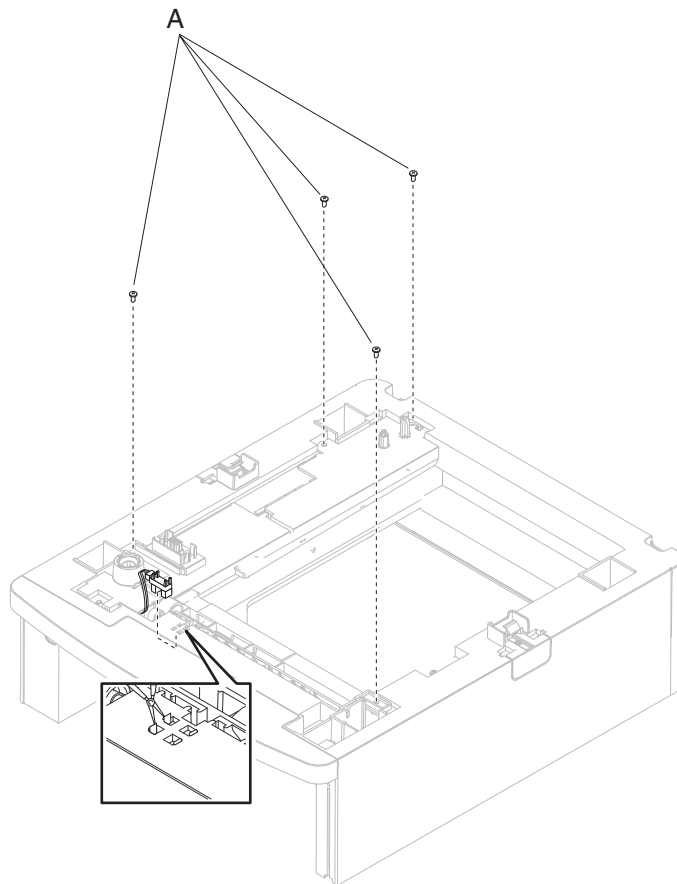

5. Remove the 550-sheet frame assembly.

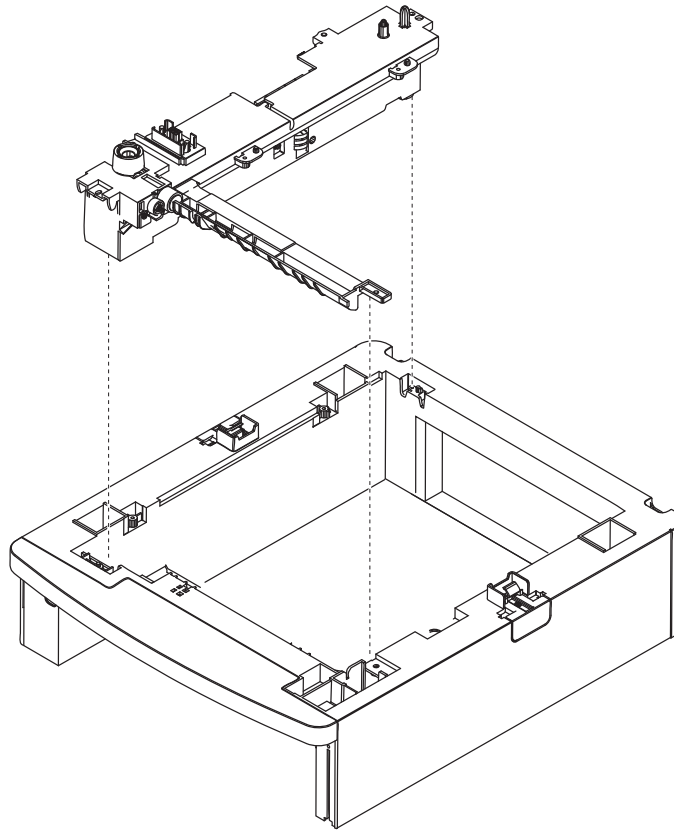

### 550-sheet controller card assembly removal

1. Remove the 550-sheet frame assembly. Go to **“Media size actuator removal”** on page 4-159.
2. Disconnect the three connectors from the 550-sheet controller card assembly.

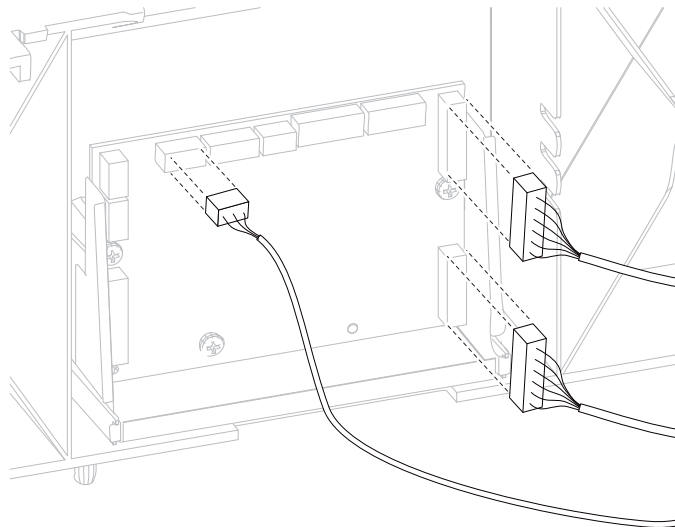

3. Remove the three screws (A) securing the 550-sheet controller card assembly to the 550-sheet frame.

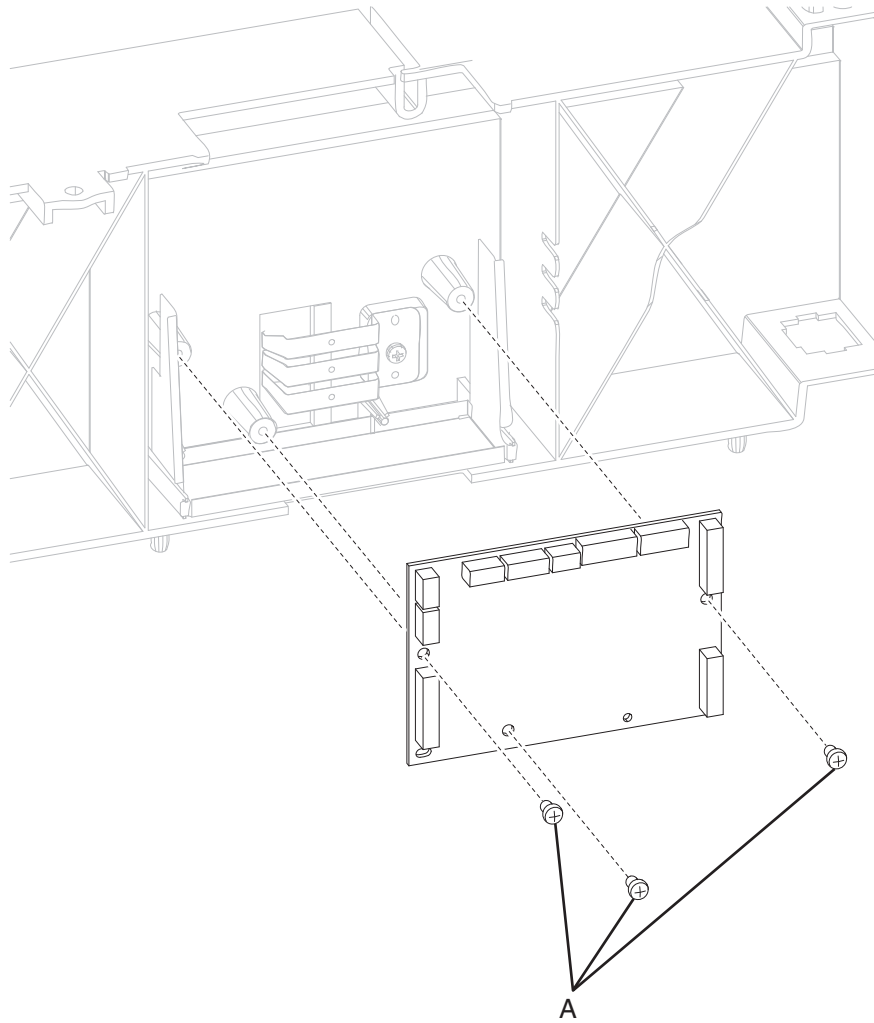

4. Remove the 550-sheet controller card assembly.

## 550-sheet option drive shaft with spring removal

1. Remove the 550-sheet frame assembly. Go to **“Media size actuator removal” on page 4-159.**
2. Pinch the two hooks (A) on the cap, and detach it from the 550-sheet frame.
3. Pull the drive roll gear (B), the shaft with spring (C), and the bevel out through the opening.

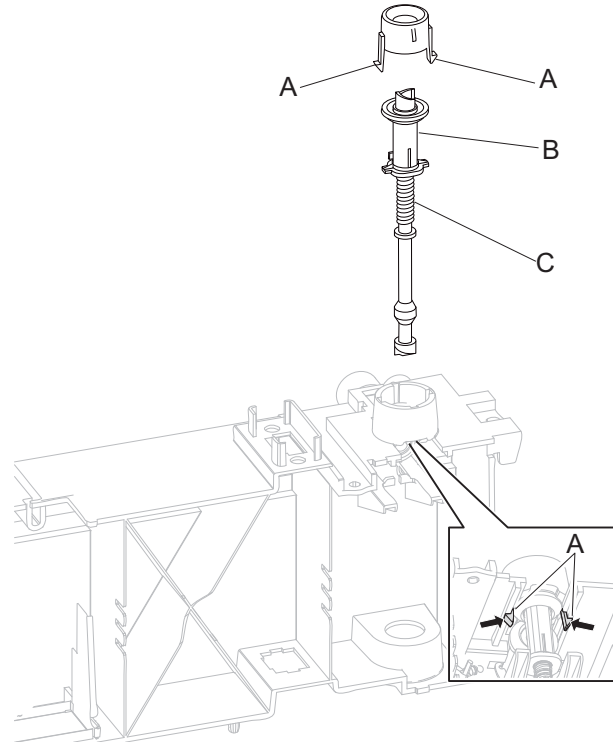

4. Remove the 550-sheet option drive shaft with spring.

## Anti-tip latch assembly removal

**Note:** Carefully remove the base machine from the input option tray assembly before proceeding.

The left and right anti-tip latch assemblies are the same, and only one is in a package. The instructions below are for removing the left latch, but removing the right latch is similar.

1. Remove the 250-sheet media tray assembly. Go to **“250-sheet option tray assembly” on page 4-101.**

2. Turn the drawer upside down, and unsnap the two hooks (A) securing the anti-tip latch assembly to the drawer with a flathead screwdriver.

**Note:** The hooks might break when detaching the anti-tip assembly from the drawer.

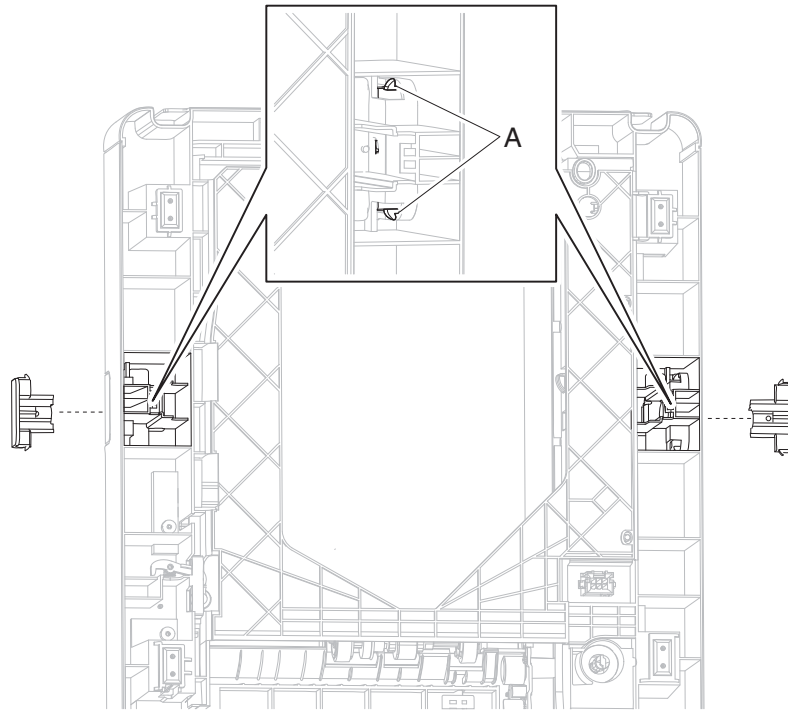

3. Remove the anti-tip latch assembly.

### High capacity input tray (HCIT)

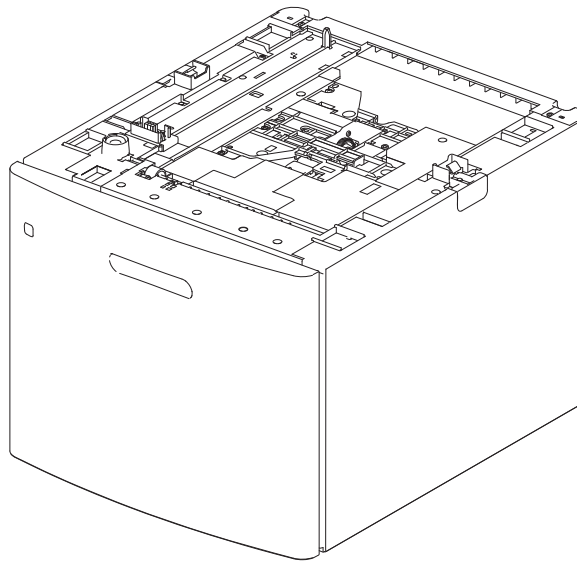

**Note:** Carefully remove the HCIT from the base machine and the caster base before proceeding.



## High capacity input tray (HCIT) media tray assembly removal

1. Open the HCIT media tray assembly until it reaches a stop.
2. Press the latches (A) on the left and right sides of the HCIT tray slides.

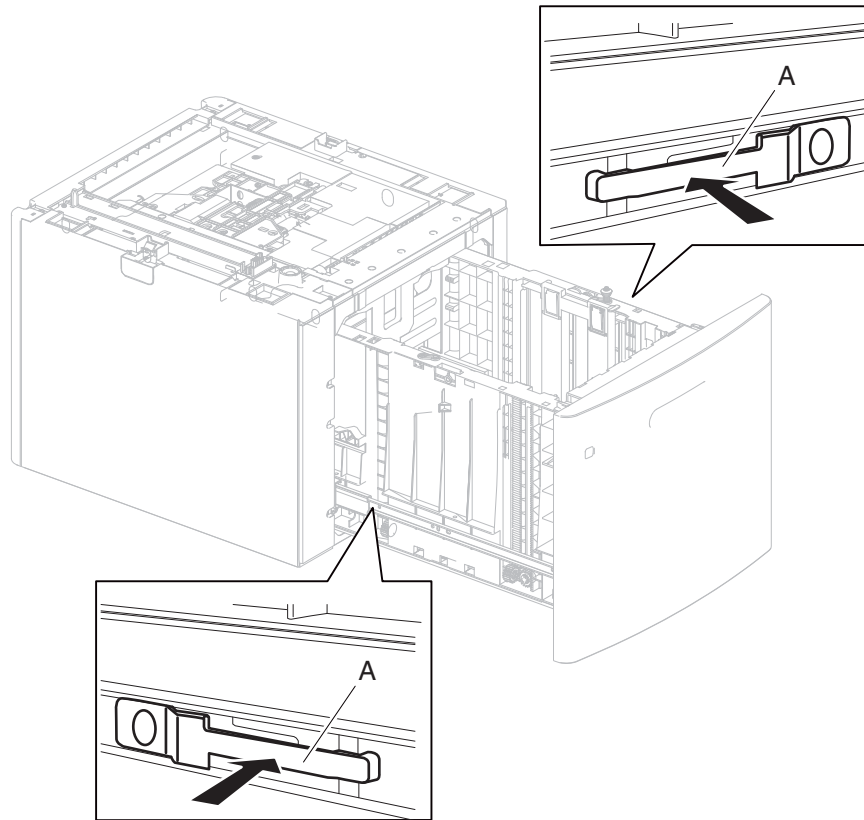

3. Slide the HCIT media tray assembly out of the drawer.

## High capacity input tray (HCIT) tray cover, front removal

1. Open the HCIT media tray assembly until it reaches a stop.
2. Remove the six screws (A) securing the HCIT tray cover, front to the HCIT media tray assembly.

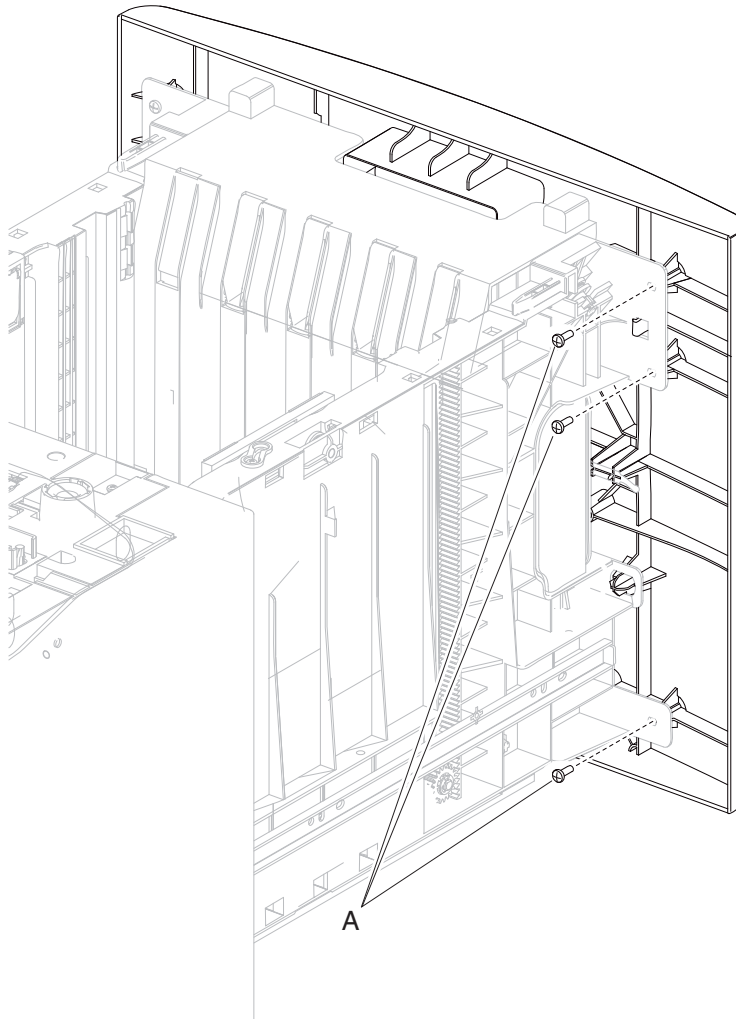

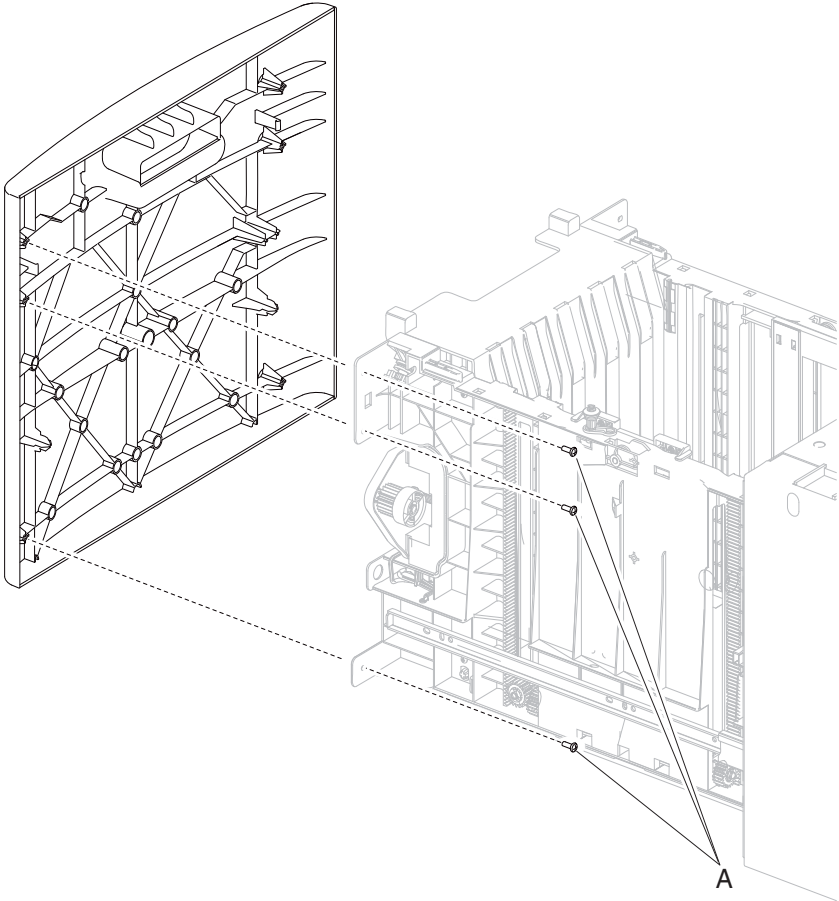

3. Remove the HCIT tray cover, front.

## High capacity input tray (HCIT) cover, rear removal

1. Remove the HCIT media tray assembly. Go to **“High capacity input tray (HCIT) media tray assembly removal” on page 4-115.**
2. Remove the four screws (A) securing the HCIT cover, rear to the drawer.

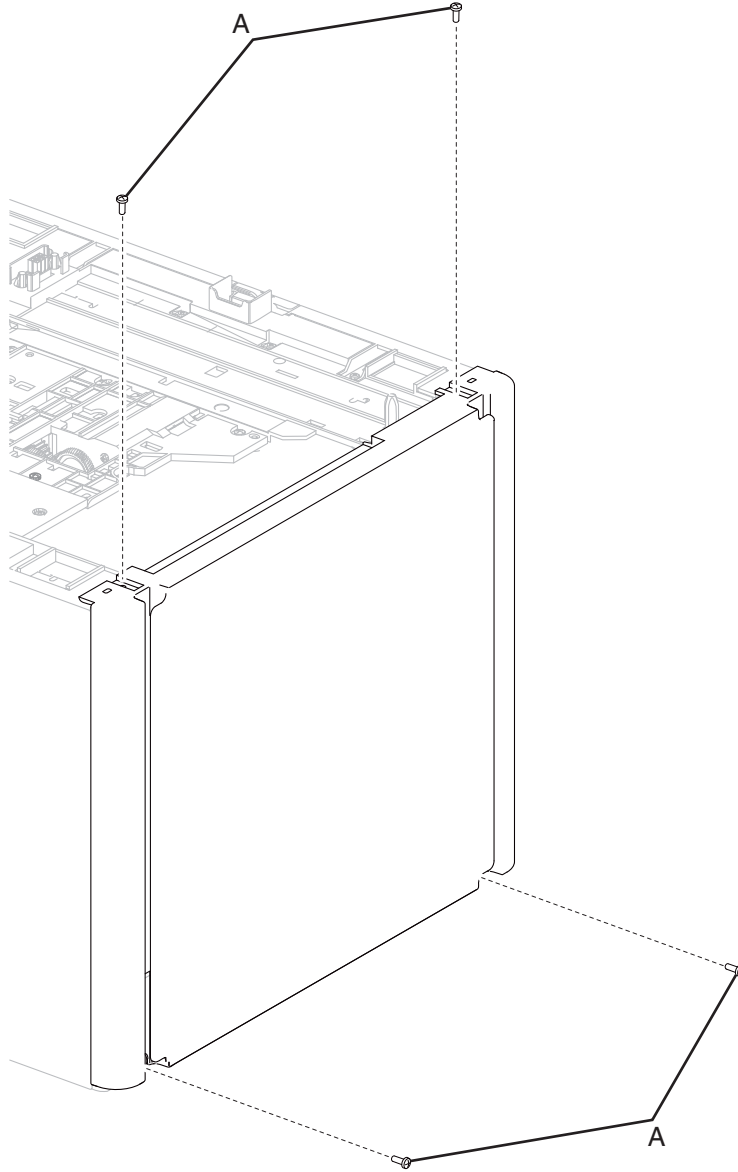

3. Remove the HCIT cover, rear.

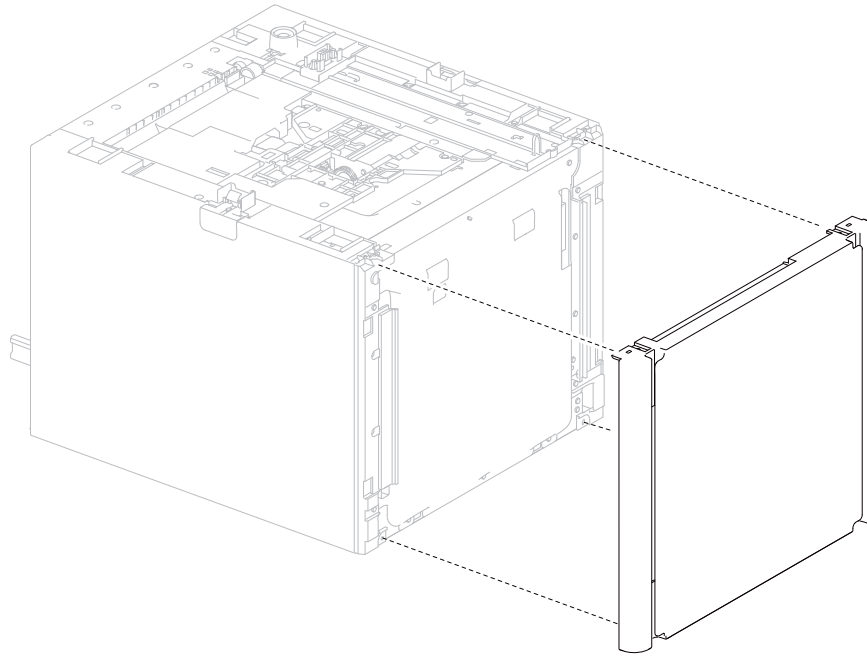

## High capacity input tray (HCIT) cover, right removal

**Note:** Carefully remove the base machine from the HCIT tray assembly before proceeding.

**Note:** Before removing the HCIT right cover, first remove the right side anti-tip latch assembly. Go to **“High capacity input tray (HCIT) anti-tip latch assembly removal” on page 4-123.**

1. Remove the High capacity input tray (HCIT) cover, rear. Go to **“High capacity input tray (HCIT) cover, rear removal” on page 4-118.**
2. Remove the four screws (A) securing the HCIT cover, right to the drawer.

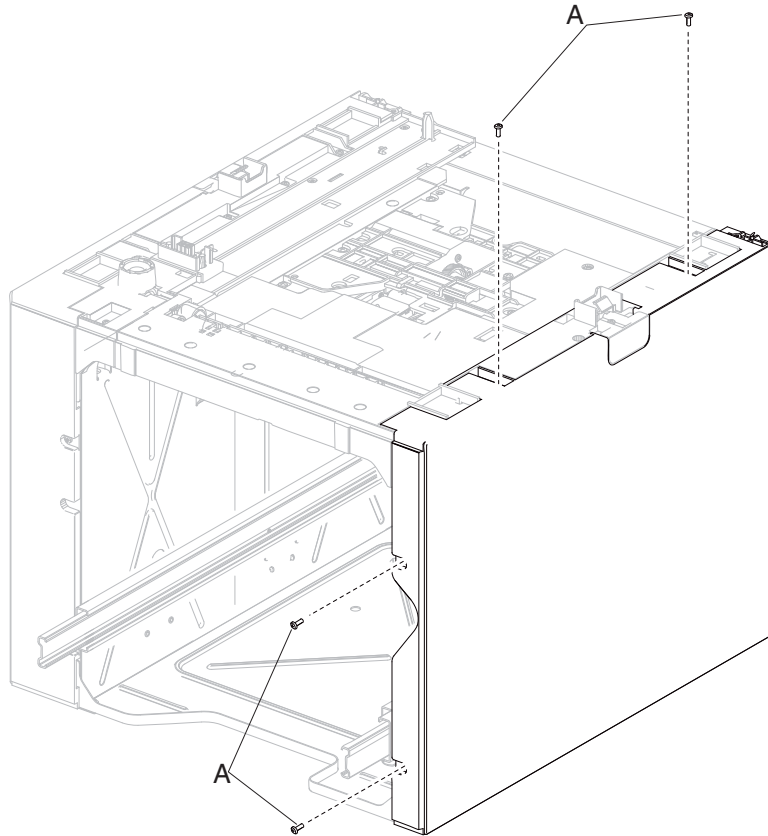

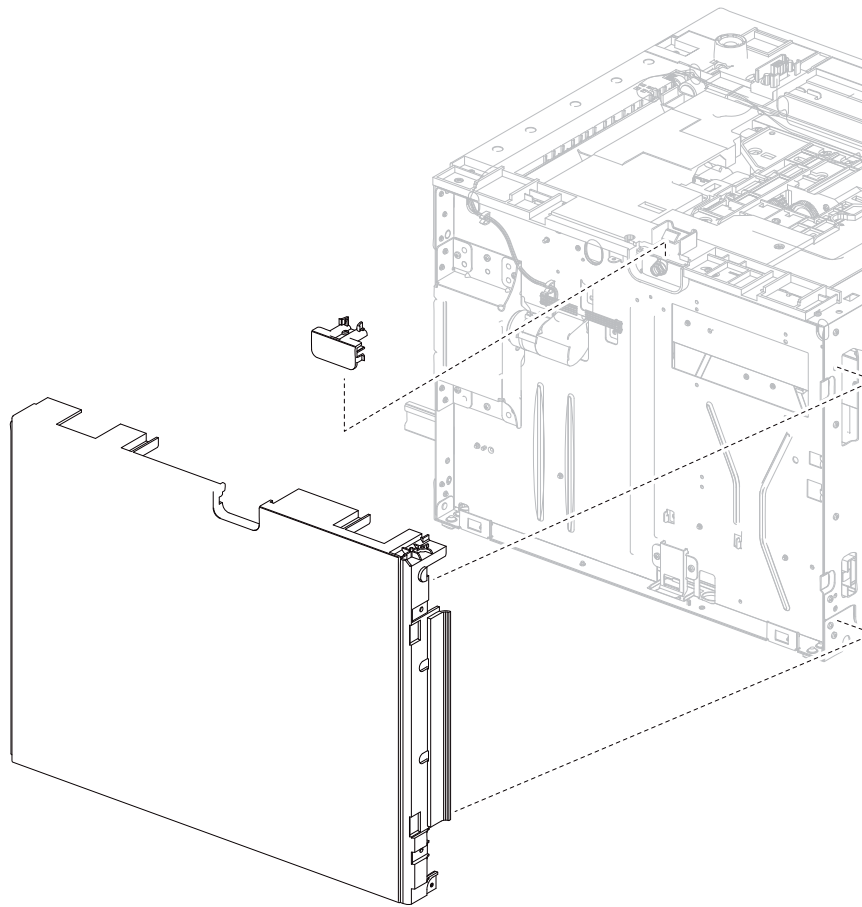

3. Remove the HCIT cover, right.

## High capacity input tray (HCIT) cover, left removal

**Note:** Carefully remove the base machine from the HCIT tray assembly before proceeding.

**Note:** Before removing the HCIT cover, left, first remove the left side anti-tip latch assembly. Go to **“High capacity input tray (HCIT) anti-tip latch assembly removal” on page 4-123.**

1. Remove the HCIT cover, rear. Go to **“High capacity input tray (HCIT) cover, rear removal” on page 4-118.**
2. Remove the four screws (A) securing the HCIT cover, left to the drawer.

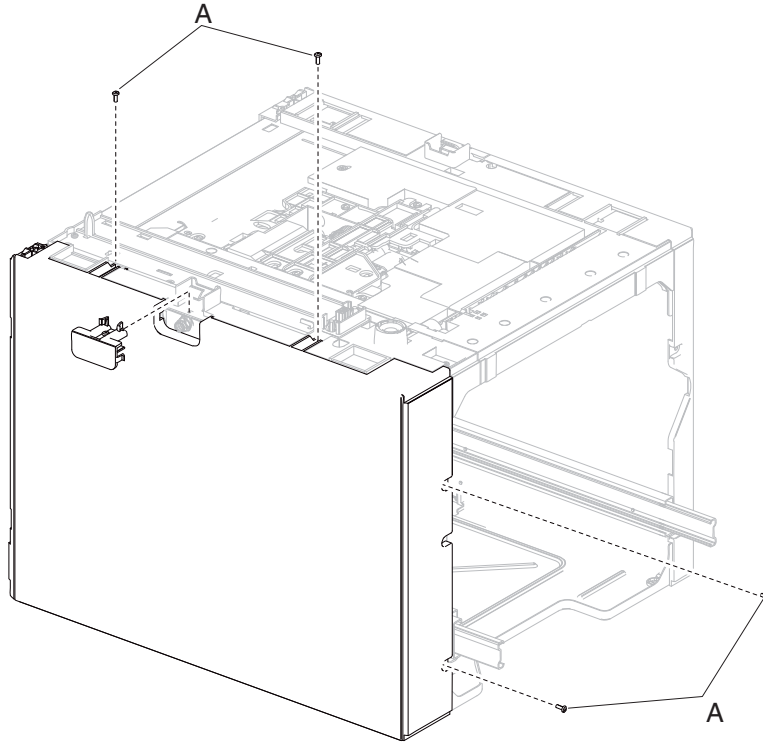



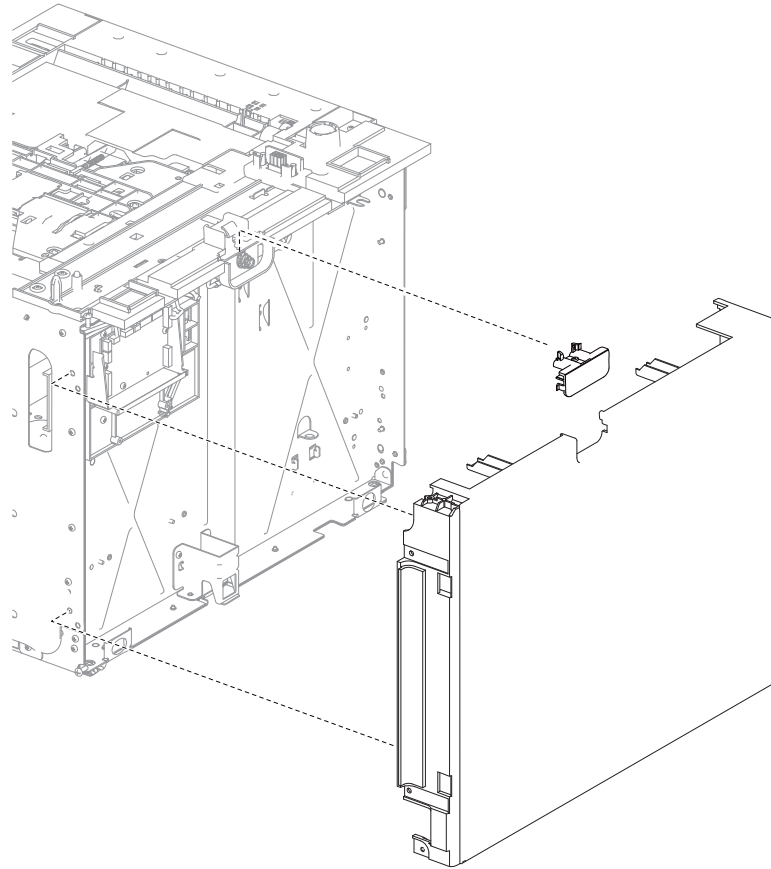

3. Remove the HCIT cover, left.

### High capacity input tray (HCIT) anti-tip latch assembly removal

**Note:** Carefully remove the base machine from the HCIT tray assembly before proceeding.

The left and right anti-tip latch assemblies are the same, and only one is in a package. The instructions below are for removing the left latch; removing the right latch has similar instructions.

1. Remove the HCIT cover, left. Go to **“High capacity input tray (HCIT) cover, left removal”** on page 4-122.

**Note:** The left side anti-tip assembly will come off when removing the HCIT cover, left.

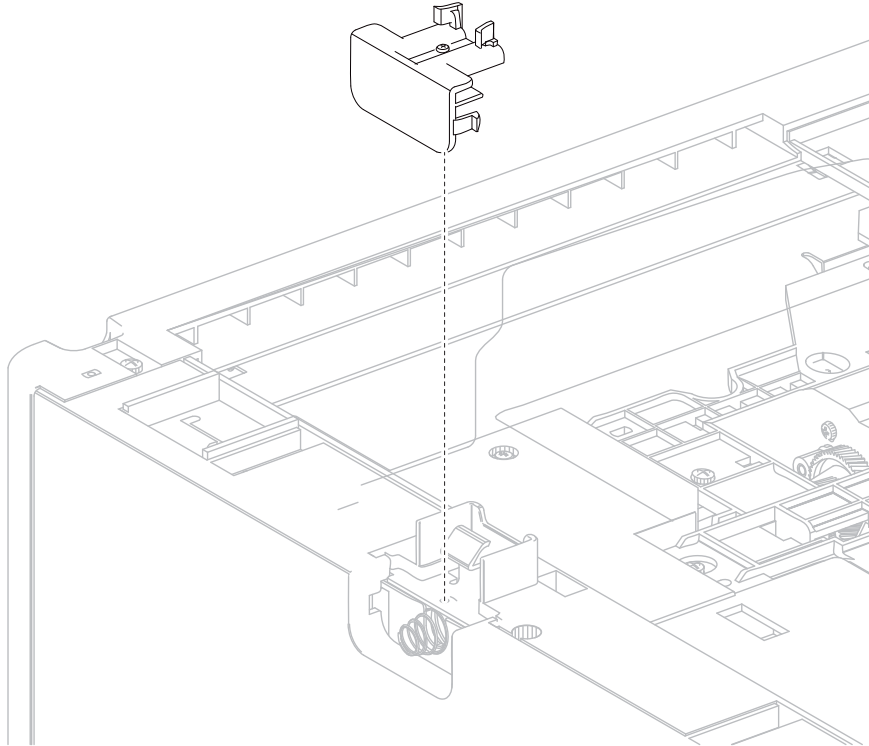

### High capacity input tray (HCIT) drawer slide assembly removal

The left and right drawer slide assemblies are the same, and only one is in a package. The instructions below are for removing the left slide; removing the right slide has similar instructions.

1. Remove the HCIT media tray assembly. Go to **“High capacity input tray (HCIT) media tray assembly removal”** on page 4-115.
2. Remove the three screws (A) securing the HCIT drawer slide to the frame of the drawer.

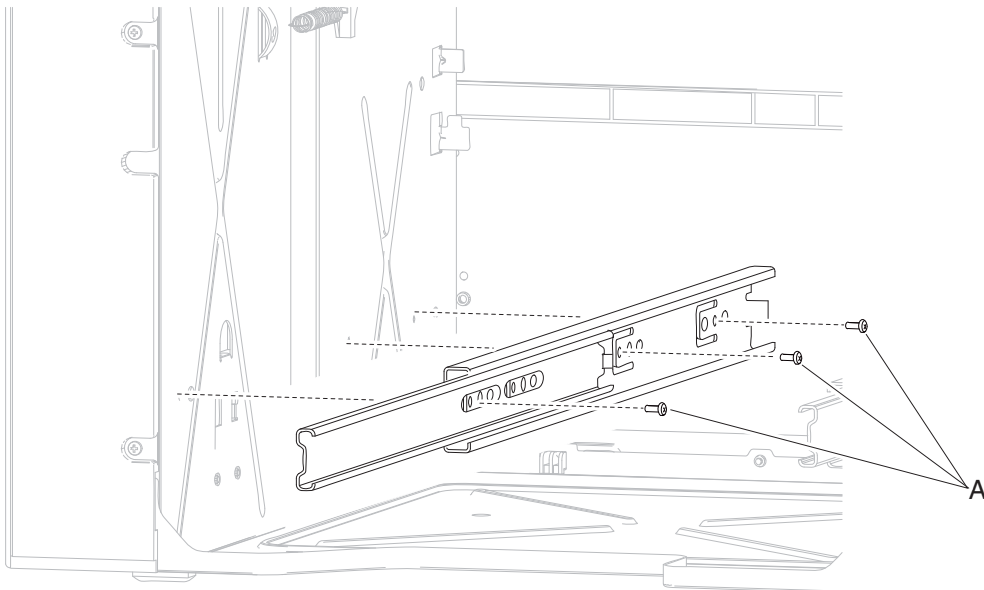

3. Remove the HCIT drawer slide.

## High capacity input tray (HCIT) tray lift drive motor assembly removal

**Note:** Carefully remove the base machine from the HCIT tray assembly before proceeding.

1. Remove the HCIT cover, right. Go to **“High capacity input tray (HCIT) cover, right removal”** on **page 4-120**.
2. Remove the HCIT cover, left. Go to **“High capacity input tray (HCIT) cover, left removal”** on **page 4-122**.
3. Disconnect the HCIT tray lift drive motor cable connector from the HCIT controller card assembly.

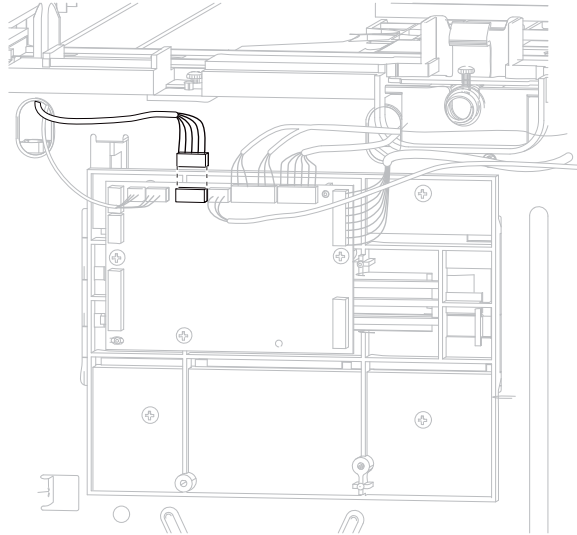

**Note:** Remove the cable from the restraint, and observe the routing for reinstallation.

4. Remove the eight screws (A) securing the HCIT tray lift drive motor assembly.

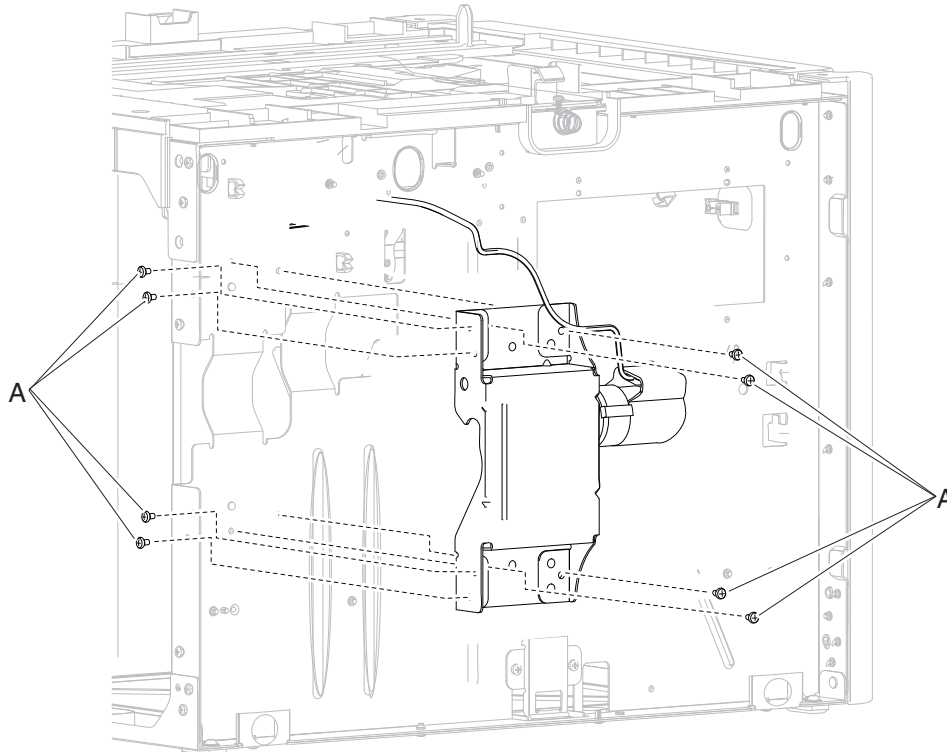

5. Remove the HCIT tray lift drive motor assembly.

## High capacity input tray (HCIT) controller card assembly removal

**Note:** Carefully remove the base machine from the HCIT tray assembly before proceeding.

1. Remove the HCIT cover, left. Go to **“High capacity input tray (HCIT) cover, left removal”** on page 4-122.
2. Disconnect all connectors from the HCIT controller card assembly.

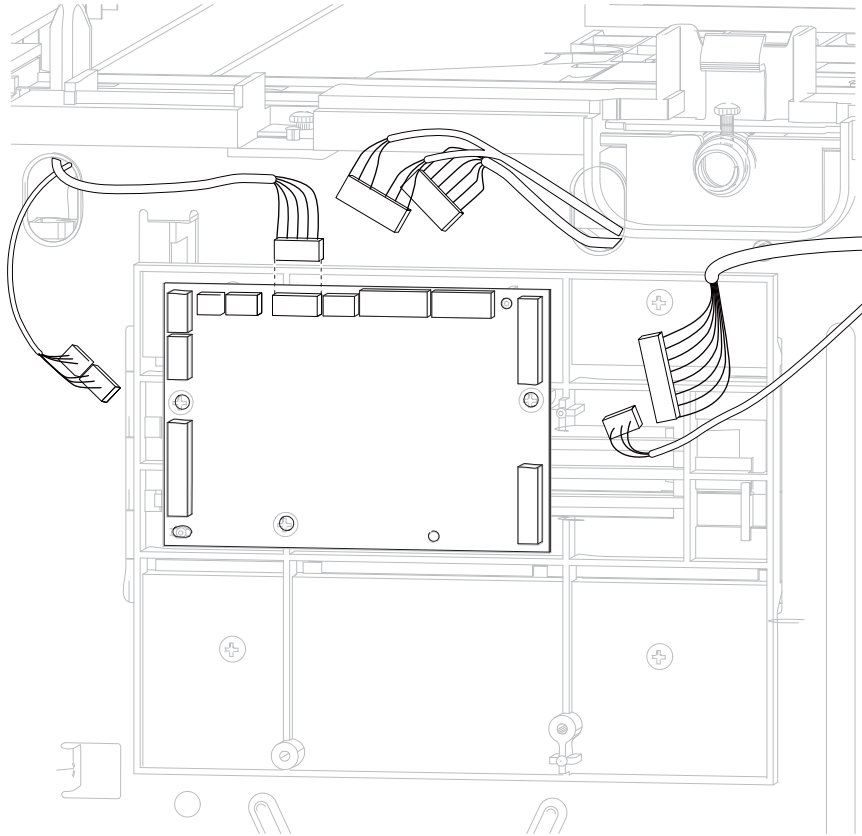

- Remove the three screws (A) securing the HCIT controller card assembly.

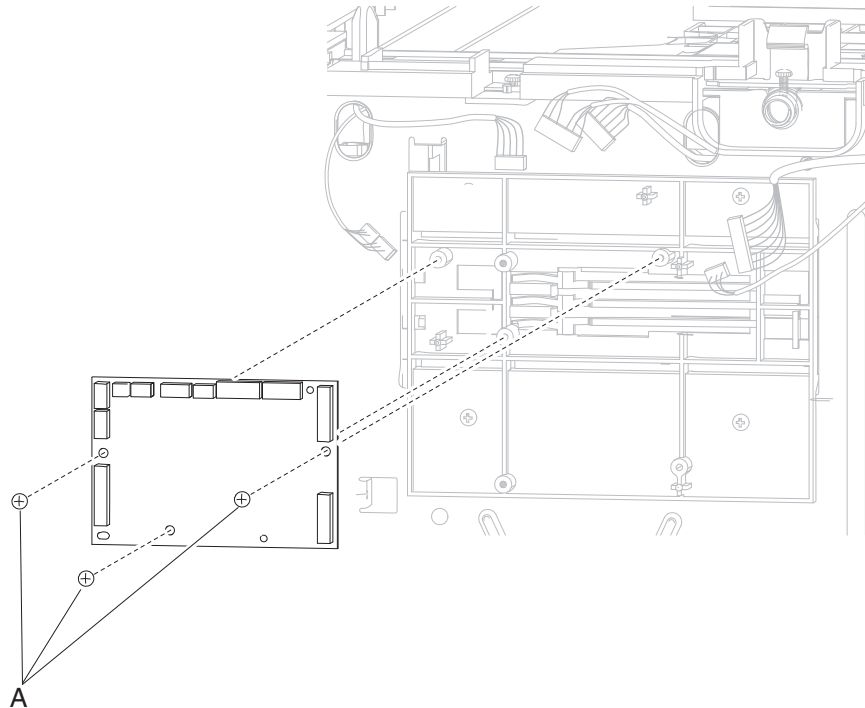

- Remove the HCIT controller card assembly and the shield.

### High capacity input tray (HCIT) media size actuator assembly removal

**Note:** Carefully remove the base machine from the HCIT tray assembly before proceeding.

- Remove the HCIT controller card assembly. Go to **“High capacity input tray (HCIT) controller card assembly removal” on page 4-126.**

- Disconnect the two springs (A) from the frame.

**Note:** Leave the springs (A) attached to the cam size sensing plate (B) and the actuator switch (C).

- Slide the cam size sensing plate (B) through the access hole in the rear side frame.

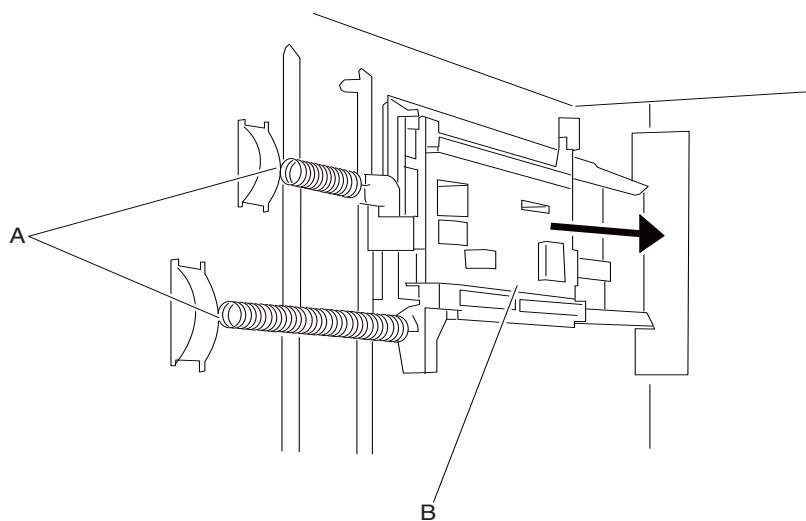

4. Snap loose the actuator switch (C) and remove.

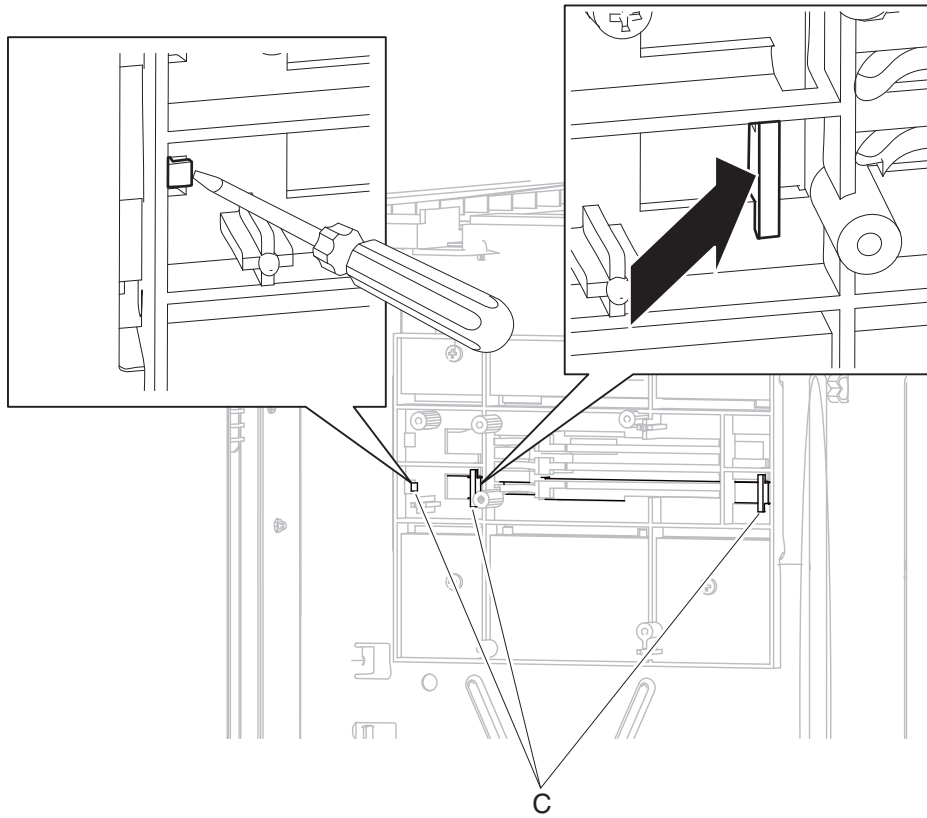

5. Remove the four screws (D) securing the card mount option with the media size actuator to the frame.

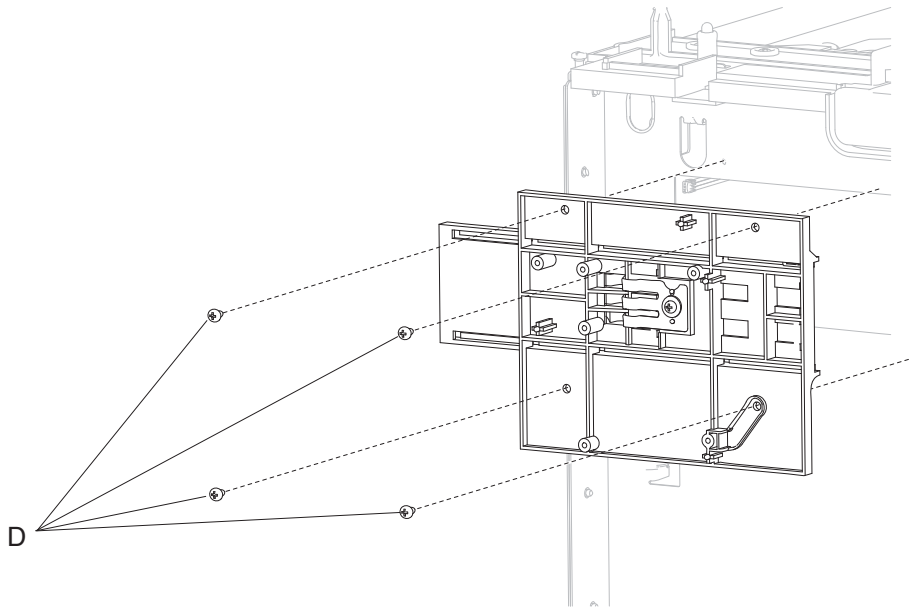

6. Remove the card mount option with the media size actuator.

**Re-installation note:**

1. Re-install the card mount option with the media size actuator to the frame by inserting the leftmost part of it through the hole, and then securing it with the four screws.
2. Re-install the actuator switch with the spring to the card mount option through the drawer opening.
3. Re-install the cam size sensing plate with the spring to the card mount option through the access hole in the rear side.
4. Reattach the two springs to the frame.

## High capacity input tray (HCIT) pick arm bracket assembly removal

**Note:** Carefully remove the base machine from the HCIT tray assembly before proceeding.

1. Remove the HCIT cover, left. Go to **“High capacity input tray (HCIT) cover, left removal”** on page 4-122.
2. Remove the HCIT pick arm bracket assembly cable connectors from the HCIT controller card assembly.

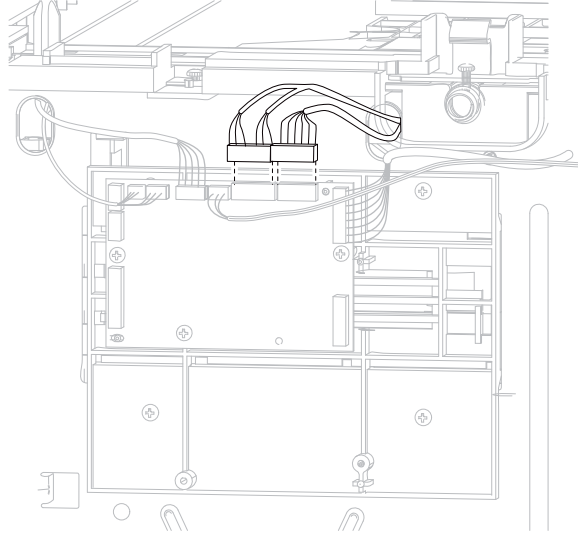

**Note:** Remove the cable from the restraint, and observe the routing for reinstallation.

3. Remove the pick arm lift spring from the drawer.

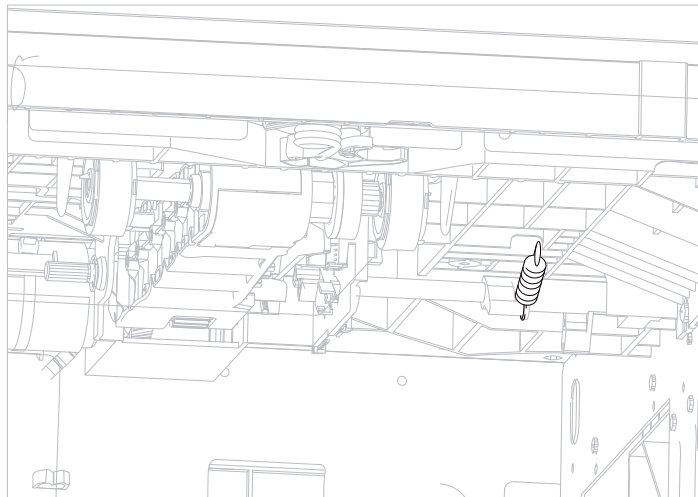



4. Remove the five screws (A) securing the HCIT pick arm bracket assembly.

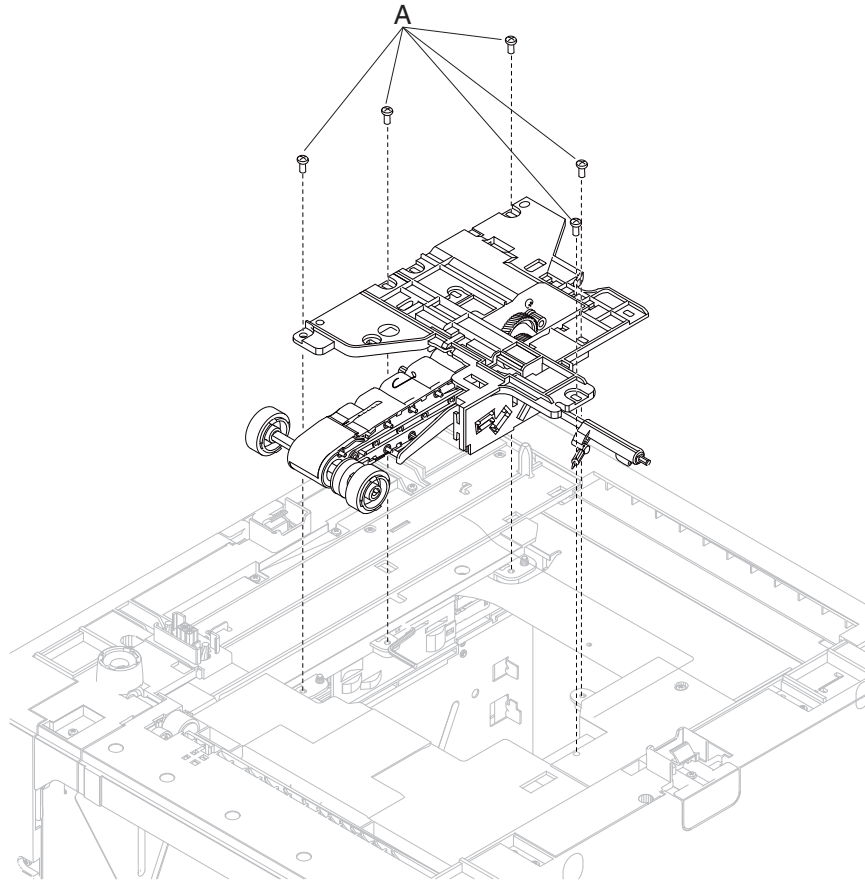

5. Remove the HCIT pick arm bracket assembly from the drawer by slightly lifting and removing it.

## High capacity input tray (HCIT) tray closed latch with spring removal

The left and right tray closed latches with springs are the same, and only one is in a package. The instructions below are for removing the left latch; removing the right latch has similar instructions.

1. Remove the HCIT media tray assembly. Go to **“High capacity input tray (HCIT) media tray assembly removal” on page 4-115.**
2. Remove the E-clip (A) and the washer (B) with a prying tool securing the HCIT tray closed latch with spring to the left frame.

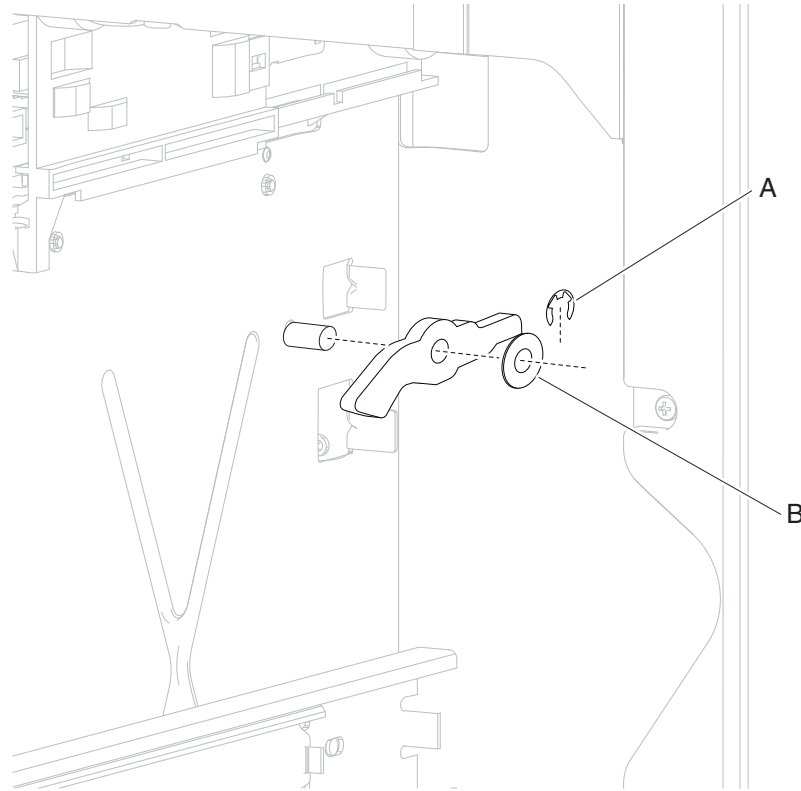

3. Remove the HCIT tray closed latch with spring.

## High capacity stacker rear door assembly removal

1. Open the rear door assembly.
2. Remove the rear door strap by twisting vertically and pulling it out of the slot.

3. Remove the rear door assembly from the hinges by gently prying the hinges off the bosses.

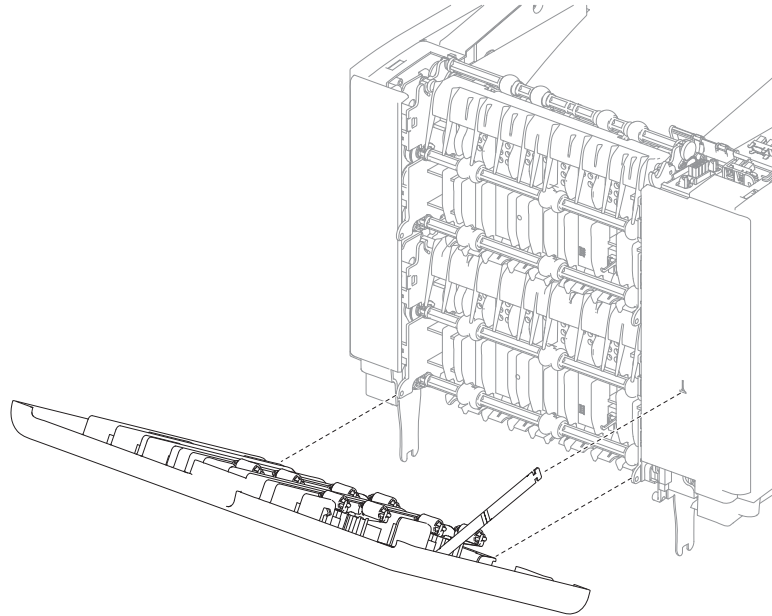

## High capacity stacker right cover removal

1. Remove the high capacity stacker rear door assembly. Go to **“High capacity stacker rear door assembly removal” on page 4-132.**
2. Using a #1 phillips screwdriver, remove the three screws (A) securing the right cover to the high capacity stacker assembly.

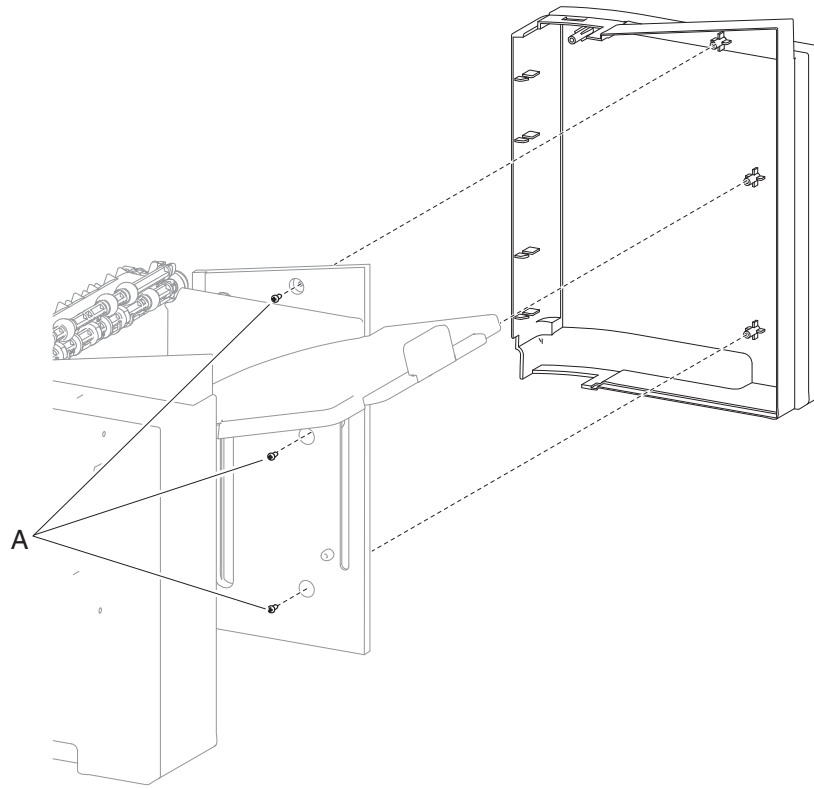

3. Remove the right cover.

## High capacity stacker left cover removal

1. Remove the high capacity stacker rear door assembly. Go to **“High capacity stacker rear door assembly removal” on page 4-132.**
2. Using a #1 phillips screwdriver, remove the three screws (A) securing the left cover to the high capacity stacker assembly.

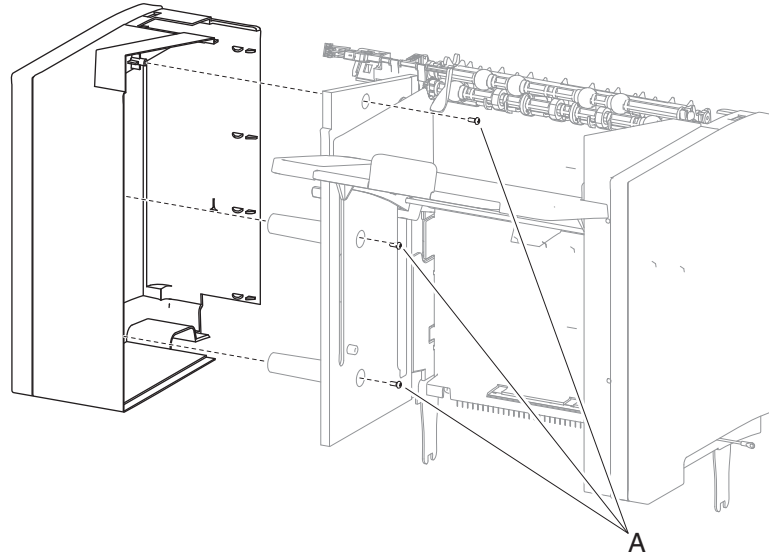

3. Remove the left cover.

## High capacity stacker media output bin assembly removal

1. Remove both the high capacity stacker media output bin recoil springs.
2. Remove the high capacity stacker standard output bin LED.
3. Carefully spread the left side of the high capacity stacker assembly and maneuver the media output bin from the assembly.

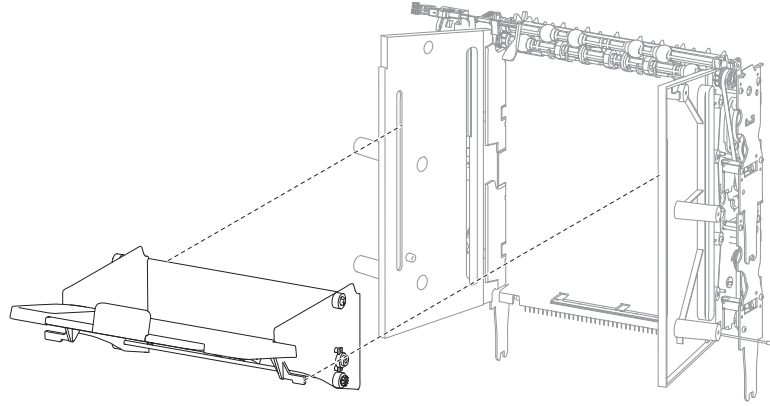

## High capacity stacker controller card cover panel removal

1. Remove the media output bin assembly. Go to **“High capacity stacker media output bin assembly removal” on page 4-136.**
2. Remove the two screws (A) securing the controller card cover panel on the rear of the assembly.
3. Remove the screw (B) securing the ground strap to the right frame.
4. Flex the controller card cover panel by grasping the bottom middle of the panel and lifting it, releasing the tabs (C) from the left and right frame.

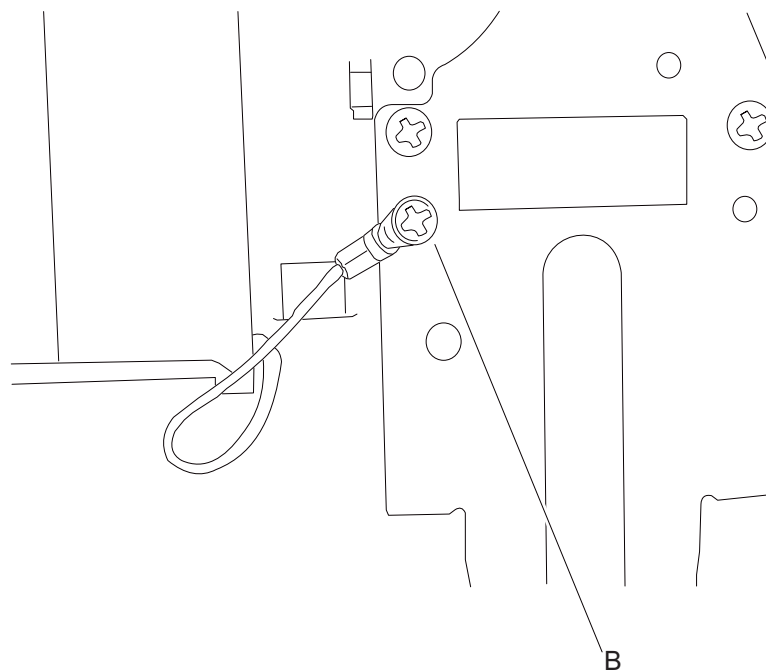
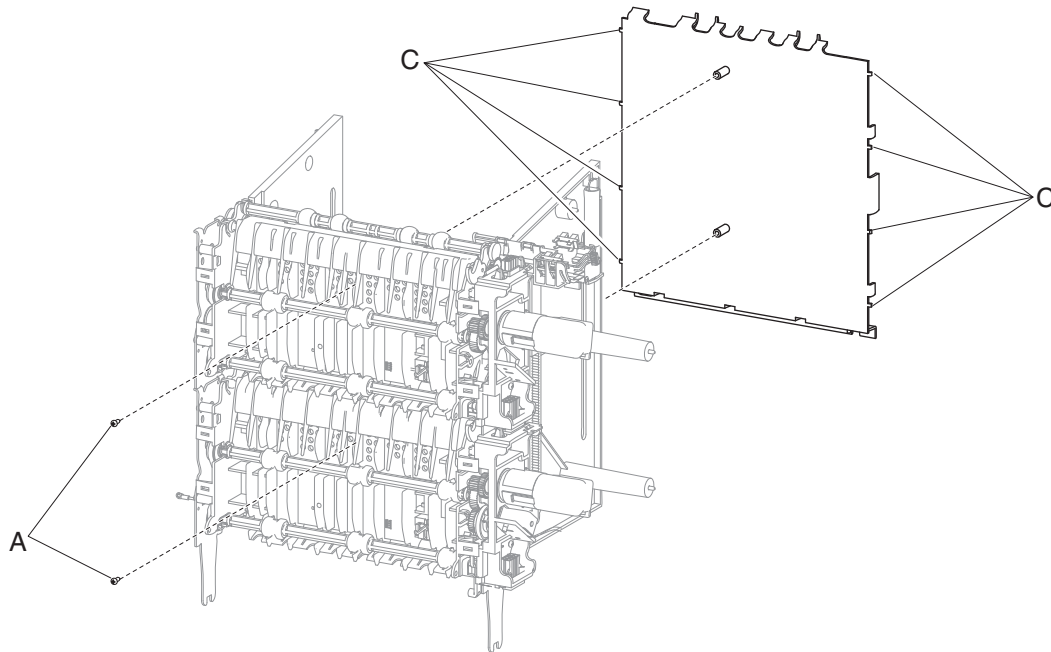

## High capacity stacker switch (media bin HP) removal

1. Remove the high capacity stacker controller card cover panel. Go to **“High capacity stacker controller card cover panel removal” on page 4-137.**
2. Remove the two screws (A) securing the high capacity stacker switch (media bin HP) to the left frame.

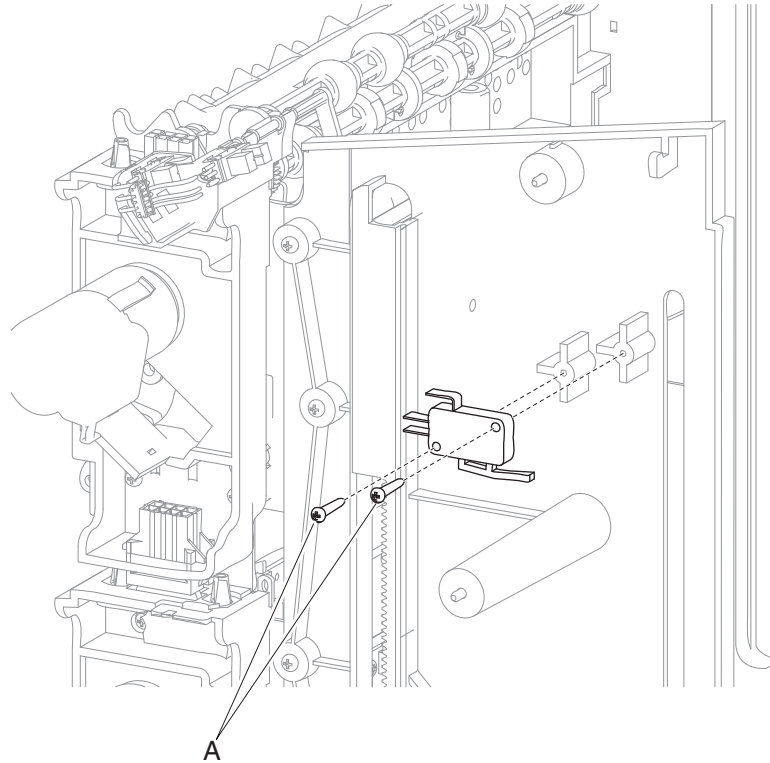

3. Disconnect the high capacity stacker switch (media bin HP) harness from the upper controller card.
4. Remove the high capacity stacker switch (media bin HP).



## High capacity stacker sensor (media bin full) assembly removal

1. Remove the high capacity stacker controller card cover panel. Go to **“High capacity stacker controller card cover panel removal” on page 4-137.**
2. Release the tabs securing the high capacity stacker sensor (media bin full) assembly to the left frame.
3. Disconnect the sensor (media bin full) harness from the upper controller card.
4. Remove the high capacity stacker sensor (media bin full) assembly.

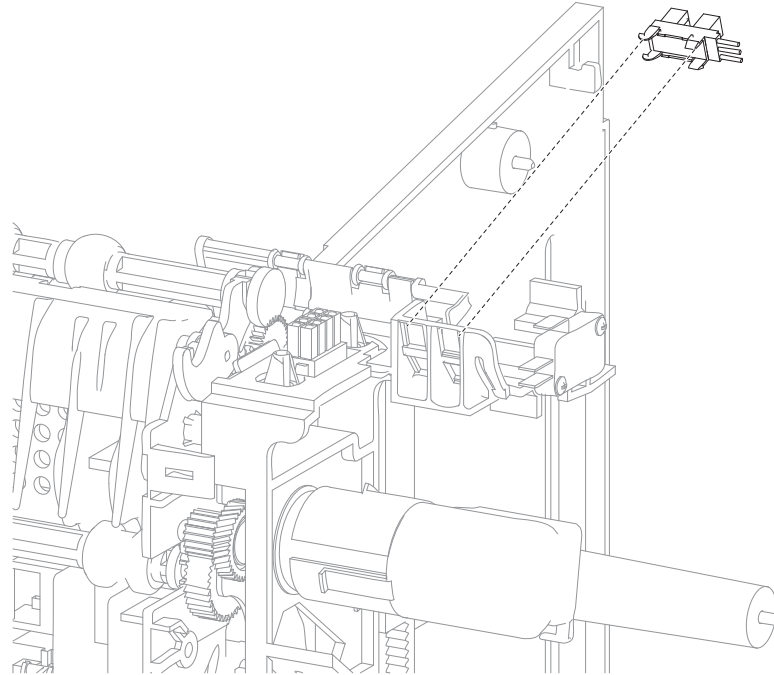

## High capacity stacker sensor (media bin full) bracket assembly removal

1. Remove the high capacity stacker left cover. Go to **“High capacity stacker left cover removal” on page 4-135.**
2. Release the tab securing the bracket to the left frame.

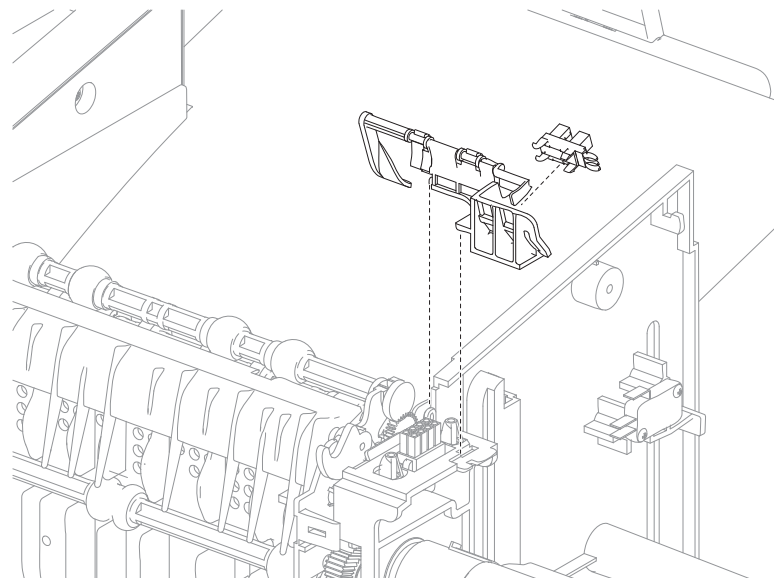

3. Remove the bracket from the frame and disconnect the sensor (media bin full) and media bin full actuator.

### High capacity stacker controller card assembly (upper and lower) removal

1. Remove the high capacity stacker controller card cover panel. Go to **“High capacity stacker controller card cover panel removal” on page 4-137.**
2. Disconnect the harnesses from the controller card.

**Note:** Pay careful attention to where the power input and output harnesses are attached.

3. Remove the two screws (A) securing the high capacity stacker controller card assembly and remove the card.

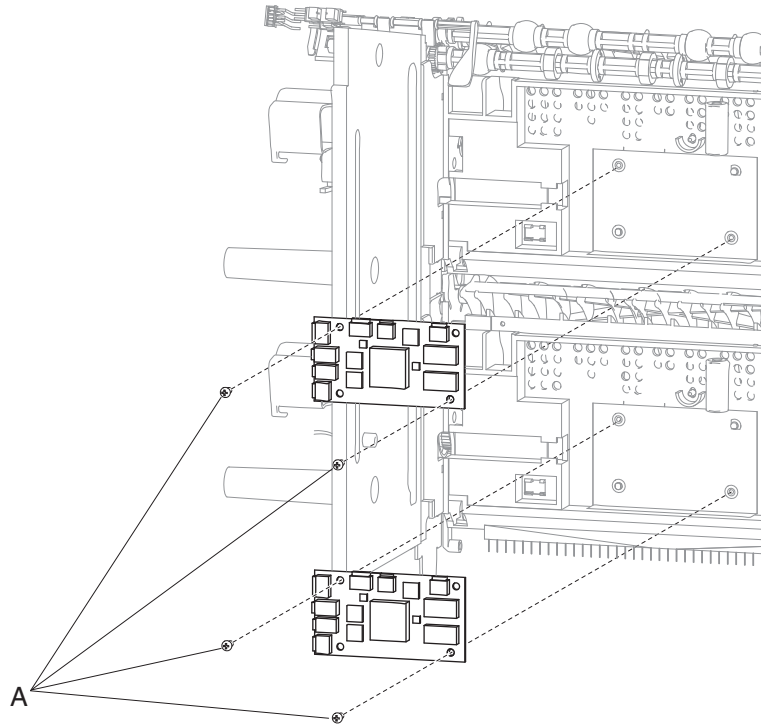

## High capacity stacker right frame removal

1. Remove the right media output bin recoil spring.
2. Remove the four screws (A) securing the right frame to the high capacity stacker assembly.
3. Carefully remove the right frame.

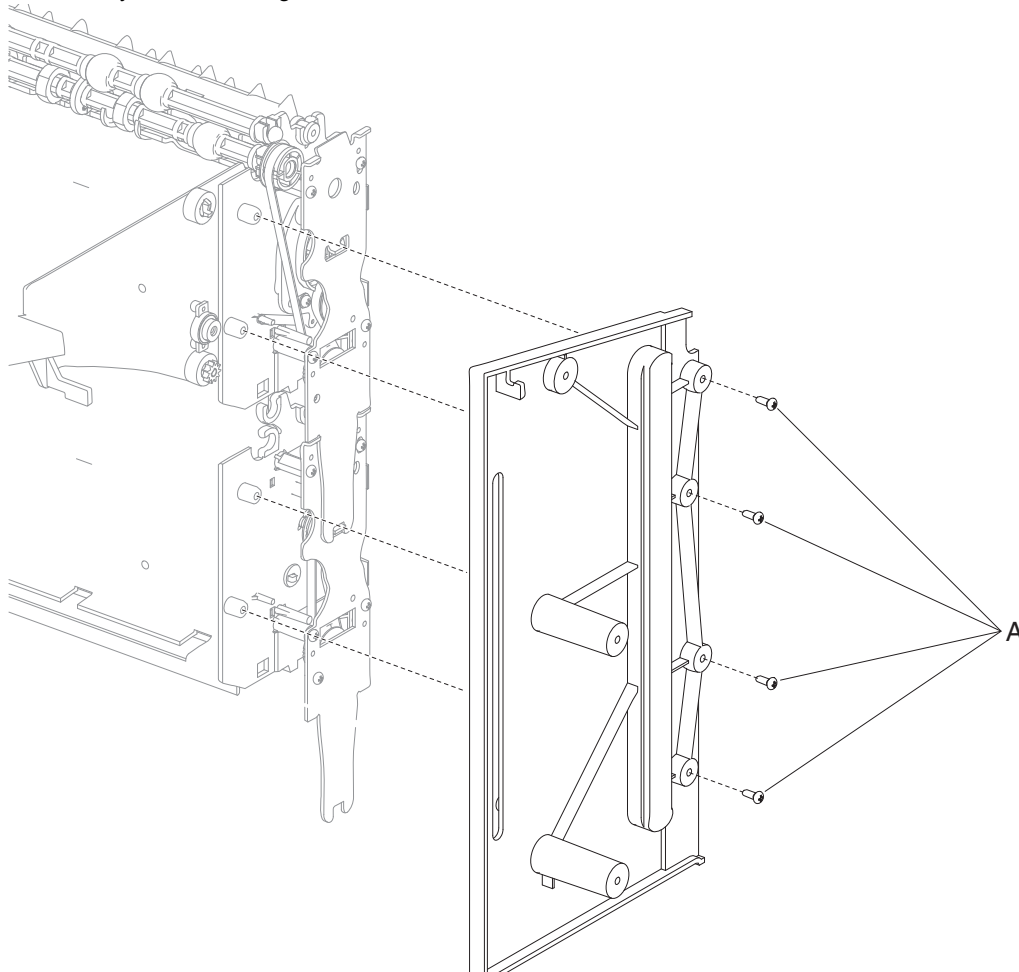

**Note:** When installing the right frame, make sure the media output bin assembly is aligned properly.

## High capacity stacker left frame removal

1. Remove the left media output bin recoil spring.
2. Remove the two screws (A) securing the switch (media bin HP) to the left frame.
3. Remove the high capacity stacker standard output bin LED.
4. Remove the four screws (B) securing the left frame to the high capacity stacker assembly.

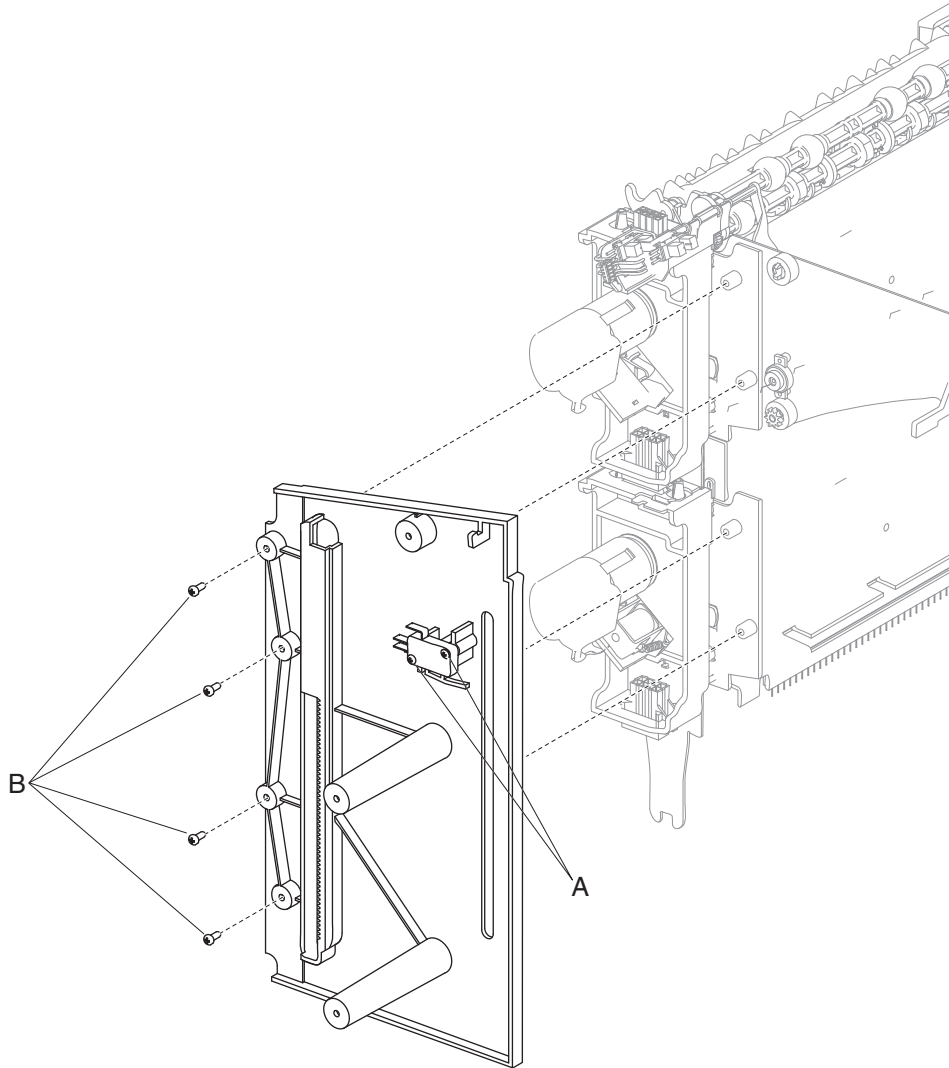

5. Carefully remove the left frame.

**Note:** When installing the left frame, make sure the media output bin assembly is aligned properly.

## High capacity stacker upper deflector gate removal

1. Remove the rear door assembly. Go to **“High capacity stacker rear door assembly removal”** on **page 4-132**.
2. With a spring hook, carefully remove the upper deflector gate spring and for ease of reassembly, temporarily hook the spring to the upper frame tab.

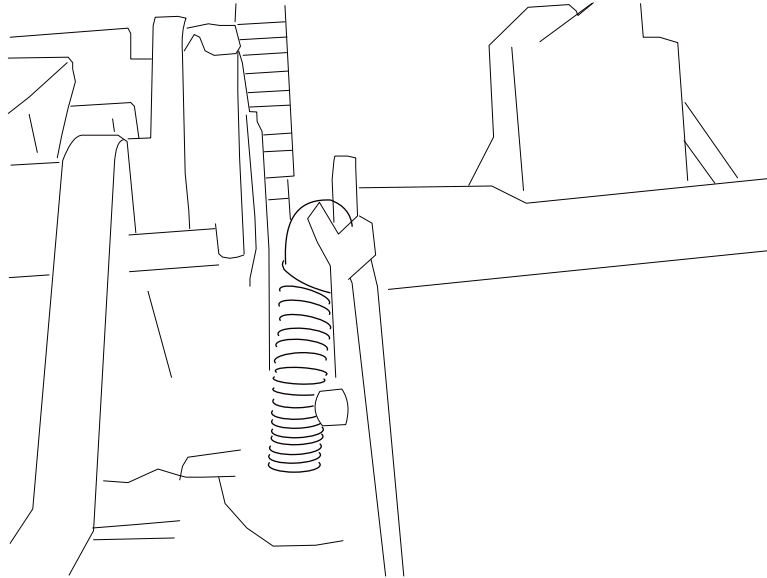

3. Unsnap each side of the deflector gate and remove.

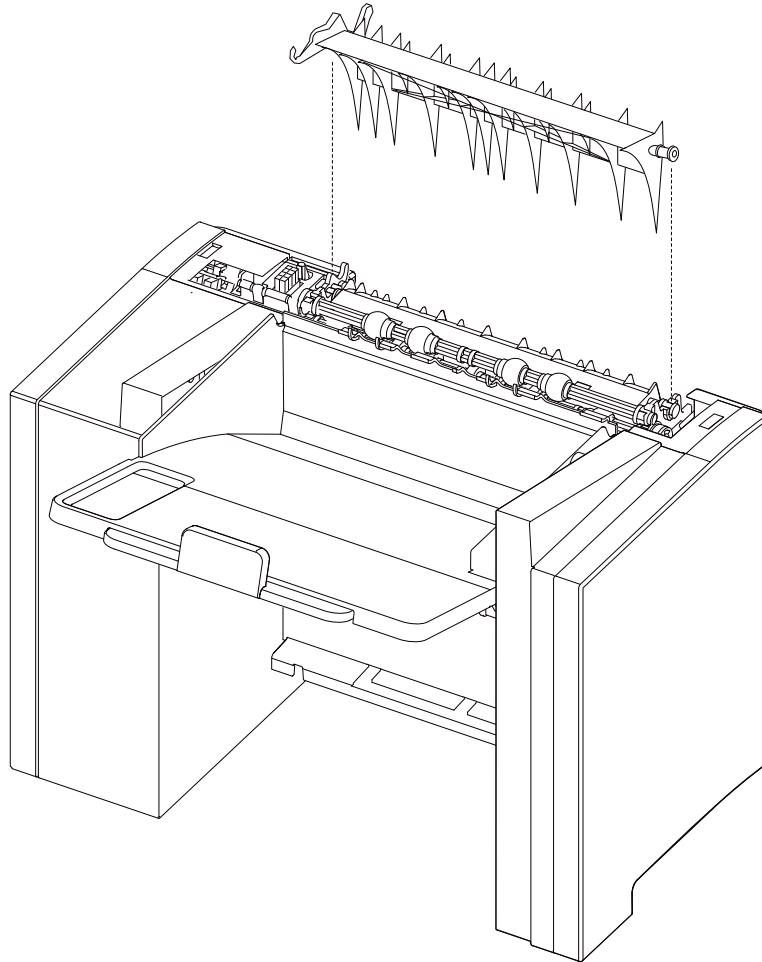

### High capacity stacker sensor (pass through) removal

1. Remove the rear door assembly. Go to **“High capacity stacker rear door assembly removal” on page 4-132.**
2. Using needle-nose pliers or your finger, pull out and downward on the sensor (pass through) until the sensor unsnaps.
3. Remove the high capacity controller card cover panel. Go to **“High capacity stacker controller card cover panel removal” on page 4-137.**

4. Disconnect the sensor (pass through) harness from the controller card and remove the sensor.

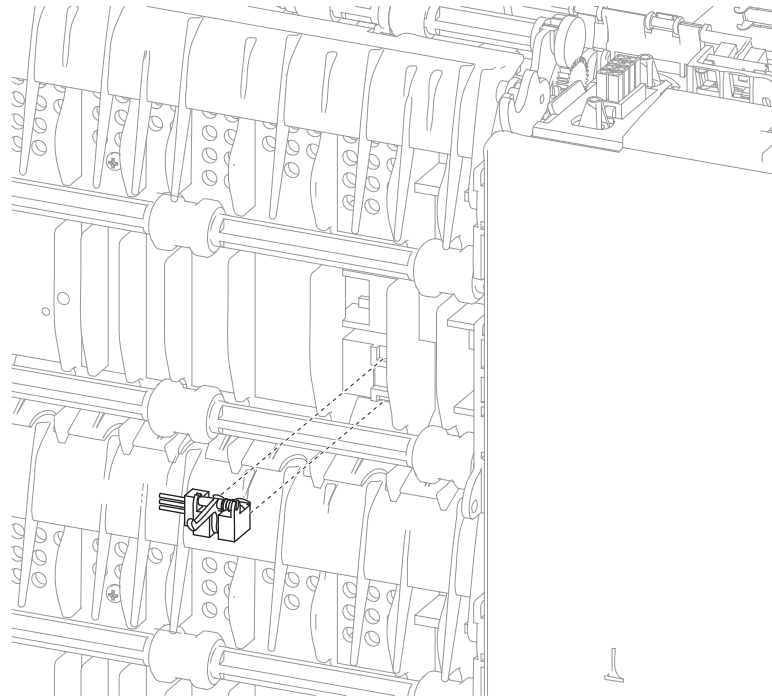

## High capacity stacker left mounting bracket removal

1. Remove the high capacity stacker left cover. **“High capacity stacker left cover removal” on page 4-135.**
2. Remove the eight screws (A) securing the high capacity stacker left mounting bracket.

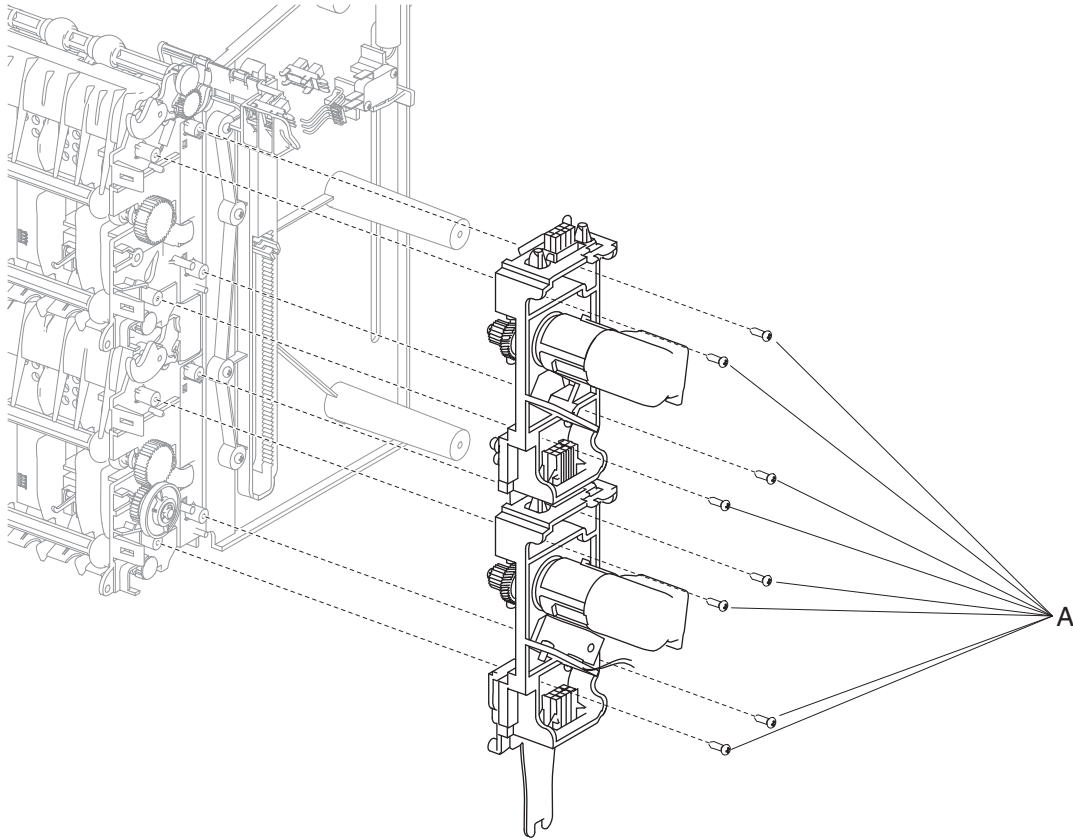

3. Pull the bracket up and let it rest on the assembly with the cables intact.



## High capacity stacker sensor (deflector gate HP) removal

1. Remove the high capacity stacker left mounting bracket. Go to **“High capacity stacker left mounting bracket removal” on page 4-146.**
2. Remove the harness from the sensor.
3. Unclip the sensor tabs and remove.

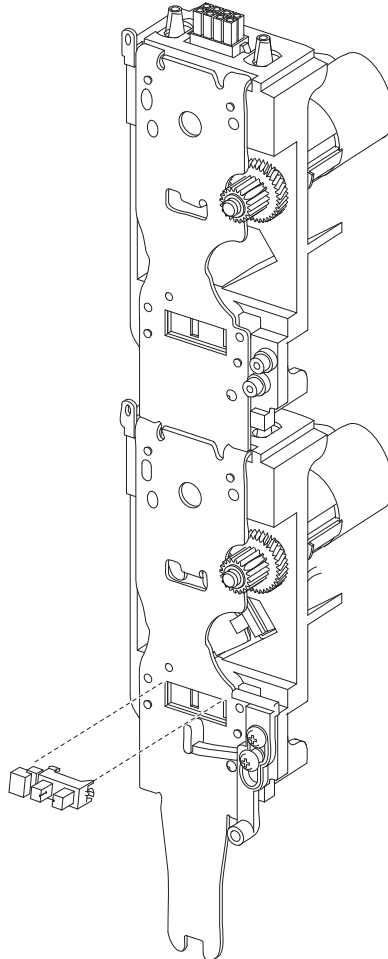

## Installing / Removing the RFID UHF option

1. RFID UHF option components:
  1. RFID UHF Option
  2. Firmware card
  3. User Flash card
  4. Fuser wiper
  5. Interface card, plastic tee, screw
  6. RFID cable
  7. Documentation CD

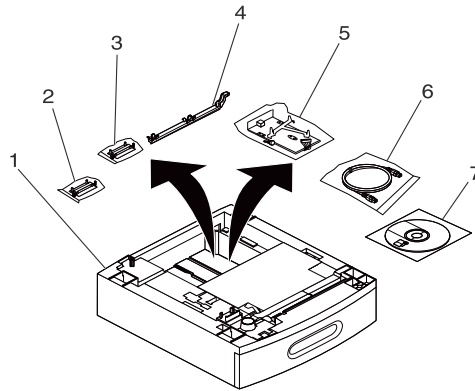

2. Unplug the power cord from the electrical outlet, and then disconnect all cables from the printer.

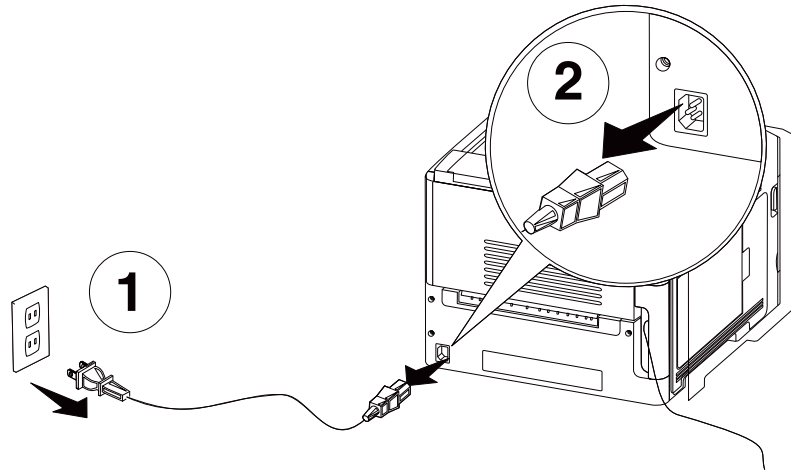

3. Open the system board door, and loosen the screw on the system board cover. Remove the cover.

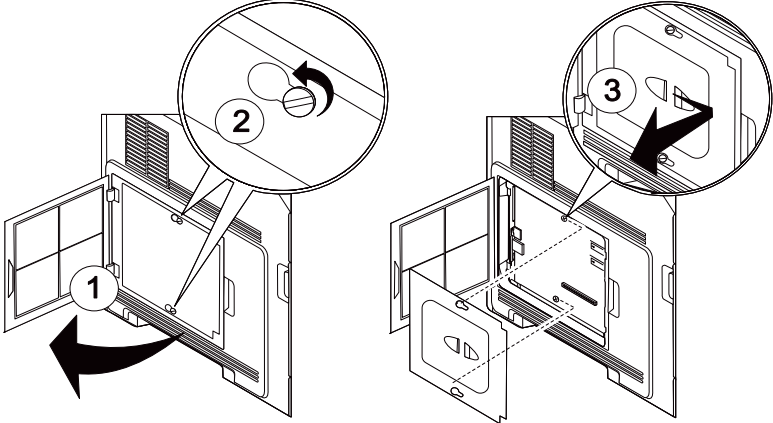

4. Install the firmware card into the system board.

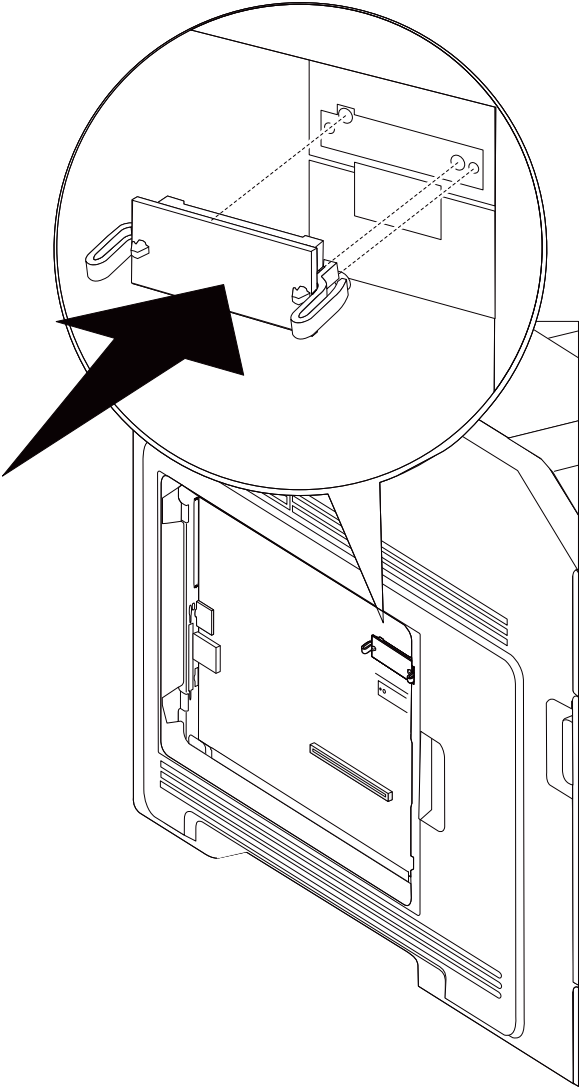

5. Install the flash card into the system board.

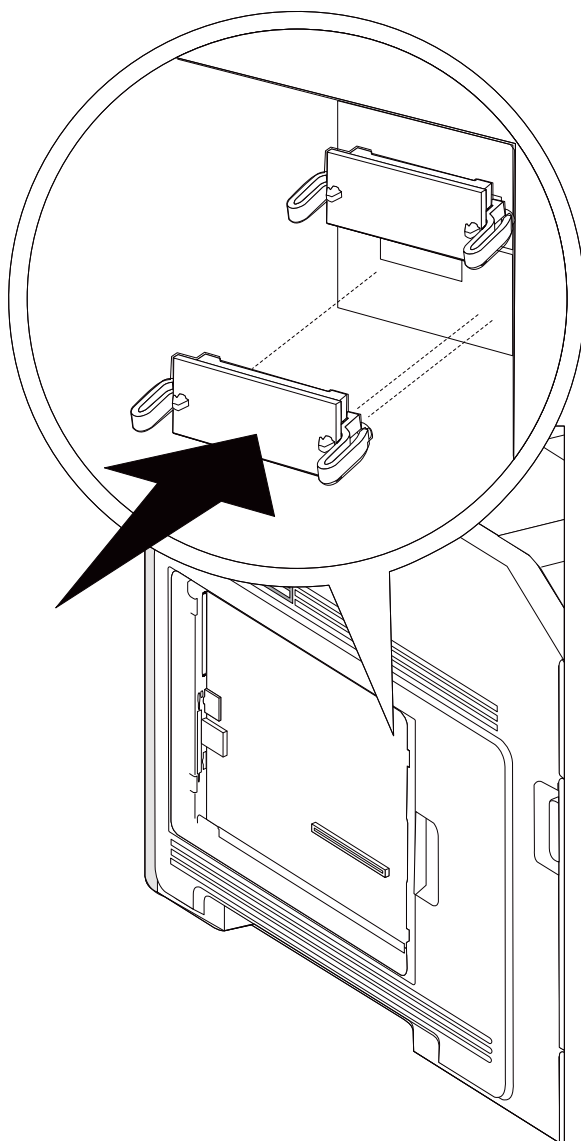

6. Remove the metal cover from the system card opening.

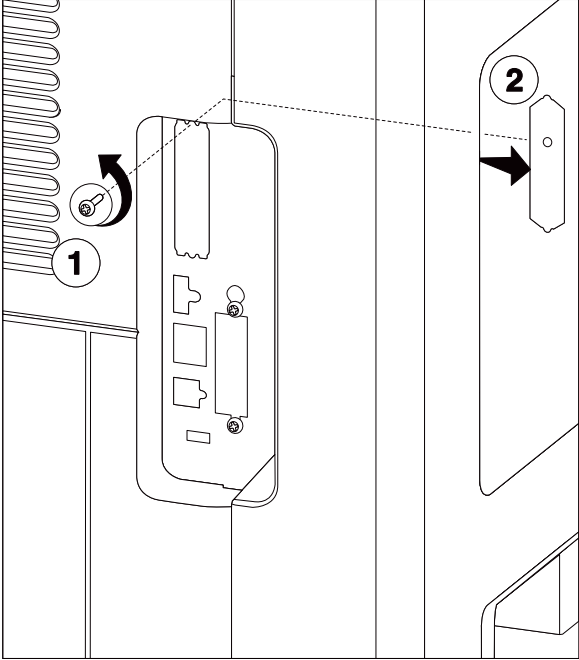

7. Locate the interface card mounting area on the system board.

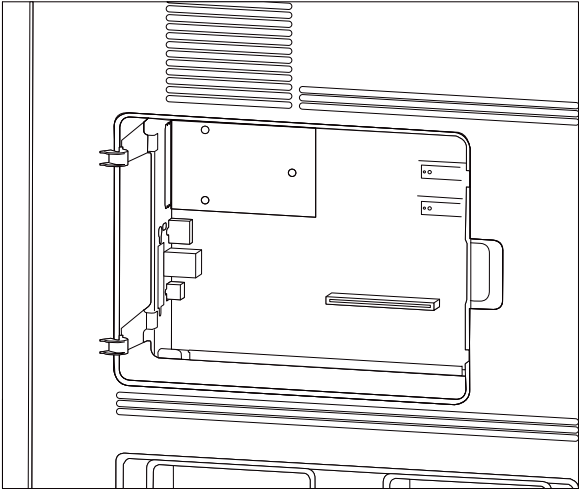

8. Snap the plastic tee card holder into place on the system board.

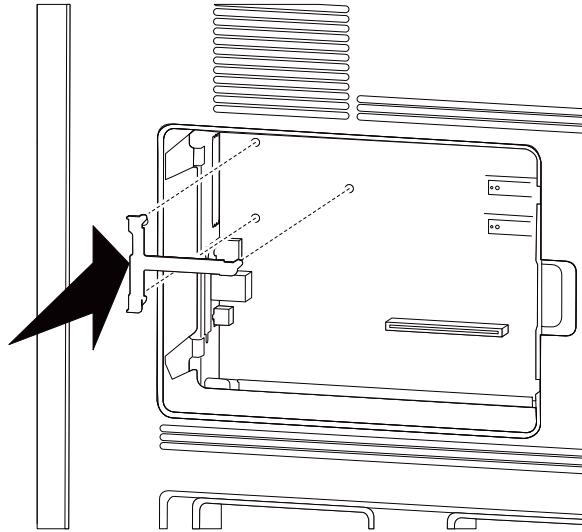

9. Angle the interface card through the connector opening.

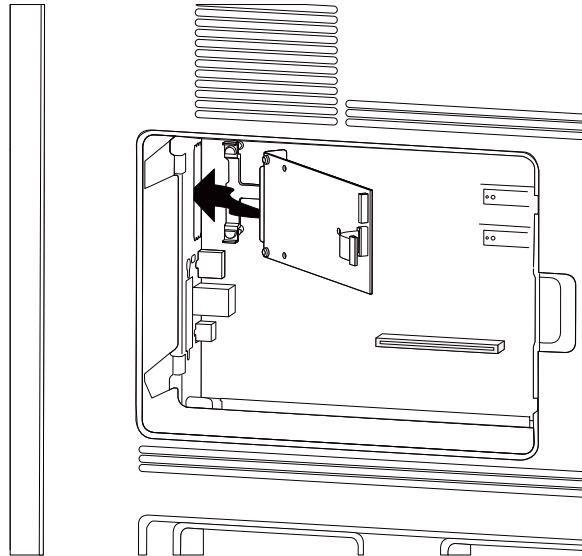

10. Insert the interface card into the plastic tee card holder.

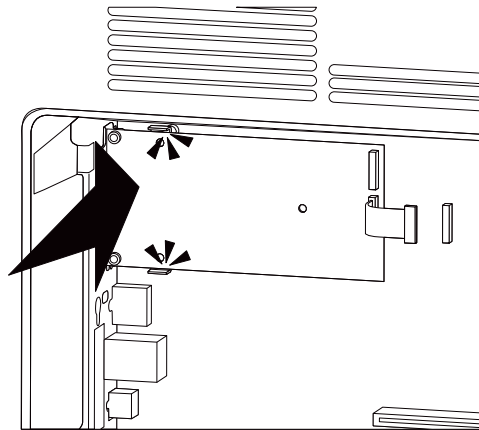

11. Insert the long thumbscrew into the hole in the interface card. Turn it just enough to hold the card in place. Do not tighten yet.

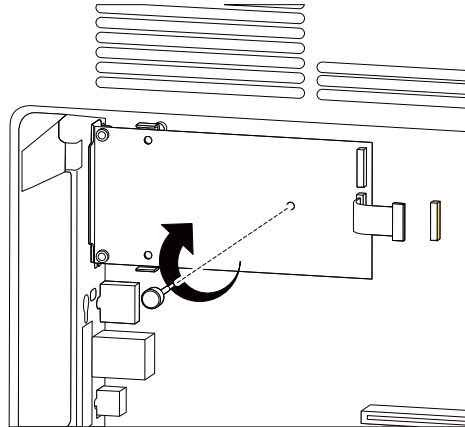

12. Insert the screws to secure the mounting bracket to the system board.

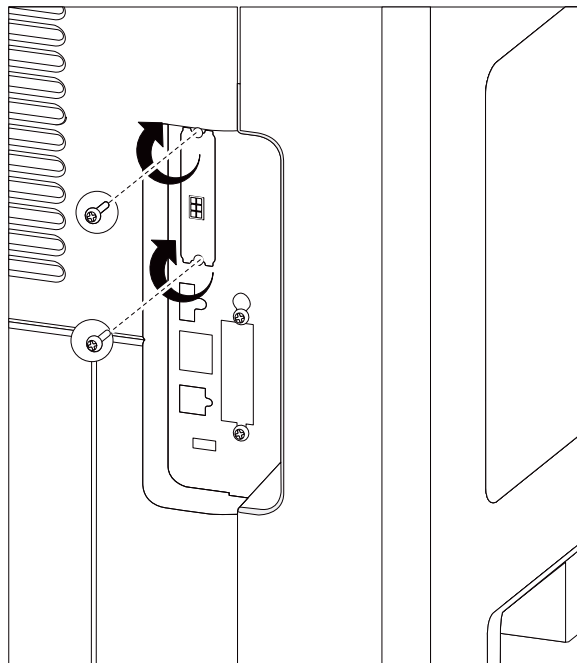

13. Tighten the thumbscrew, and insert the interface card plug into the blue connector on the system board.

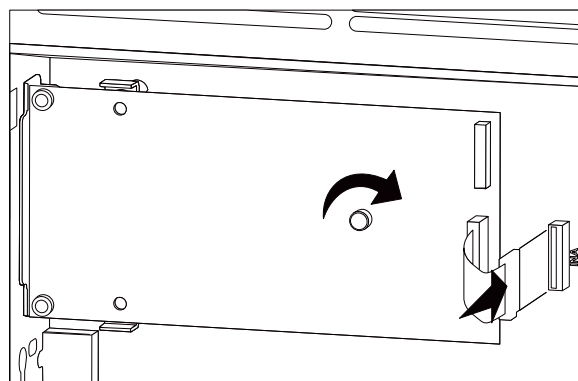

14. Replace the system board cover.

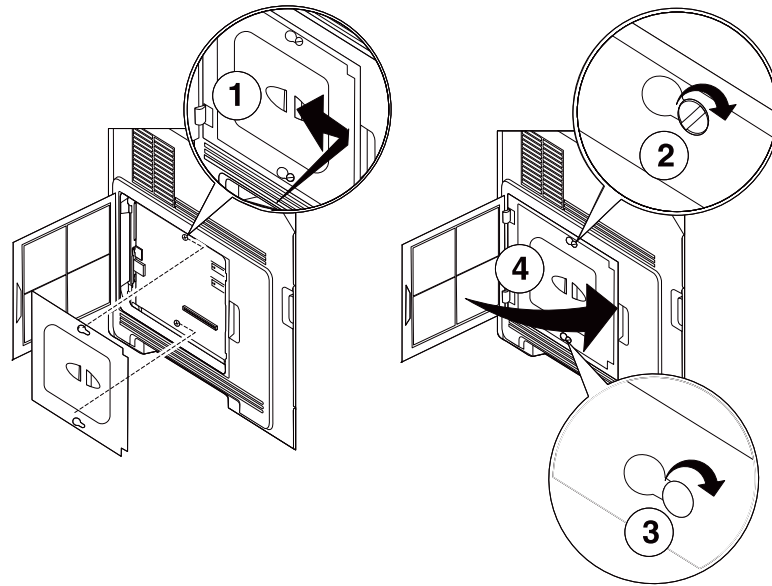

15. Lift the printer off the 250/550 sheet optional drawer, place the RFID option on top of the drawer, and place the printer on top of the RFID option.

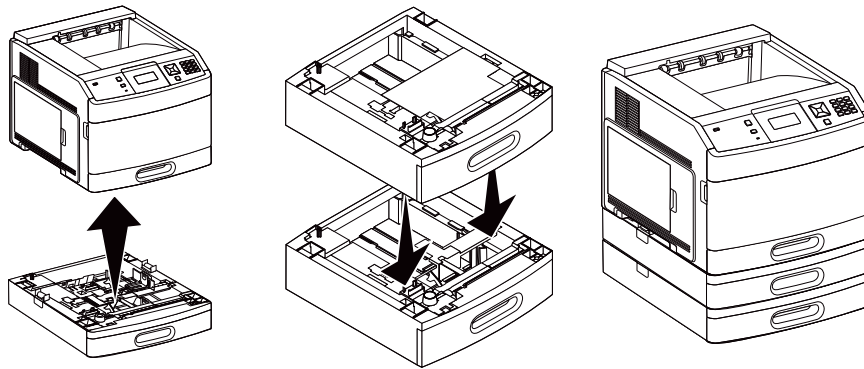



16. Unpack the RFID cable, and attach between the RFID option and the interface card. Reconnect all printer cables.

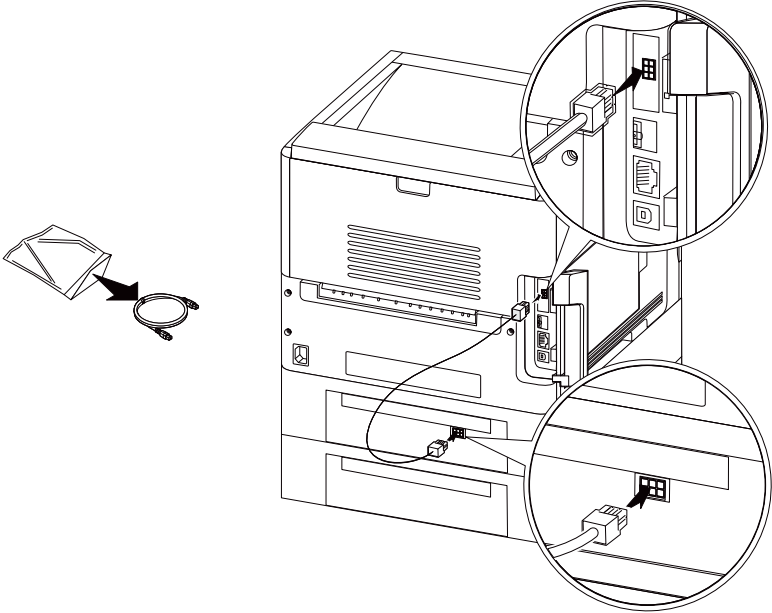

17. Remove the old fuser wiper (or blank).

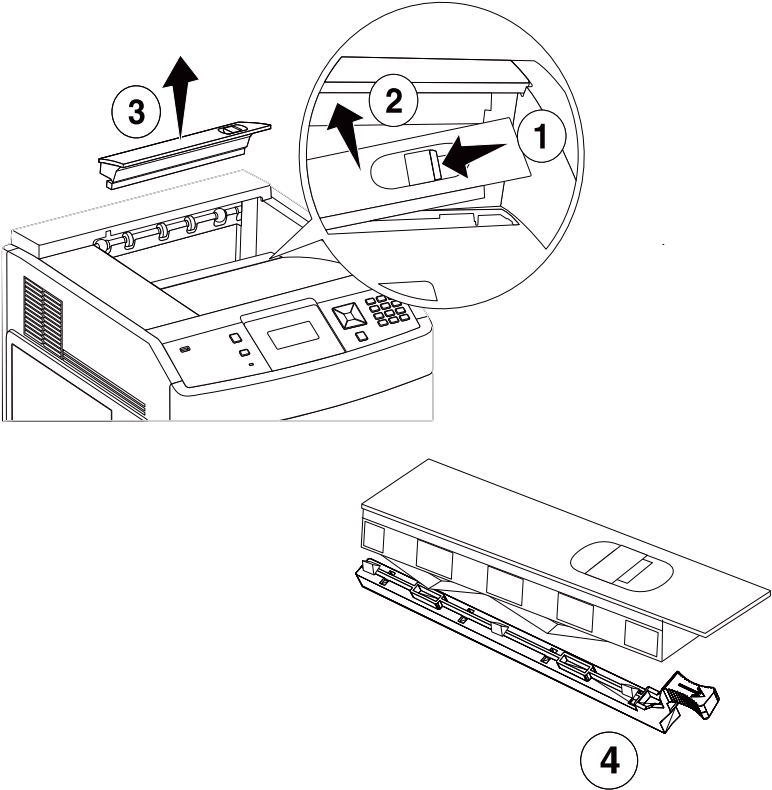

18. Install the new wiper. Turn the printer on.

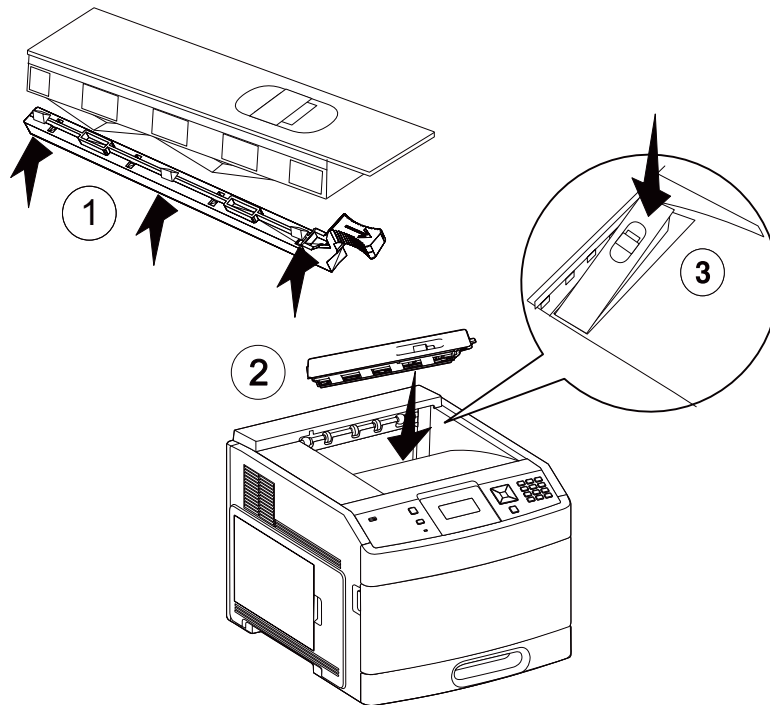

19. To remove the RFID UHF option, reverse the order of installation.

### Lower interface cable assembly removal

1. Remove the 550-sheet frame assembly. Go to **“Media size actuator removal”** on page 4-159.
2. Disconnect the lower interface cable connector (A) from the 550-sheet controller card.
3. Pinch the options auto connect (B) to separate the lower interface cable assembly from the 550-sheet frame.

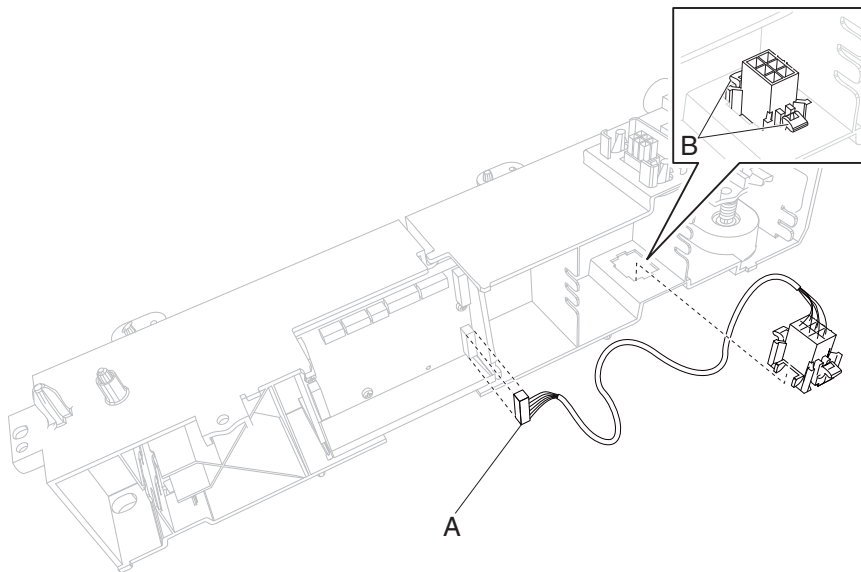

4. Remove the lower interface cable assembly.

## Media size actuator removal

**Note:** Carefully remove the base machine from the input option tray assembly before proceeding.

1. Remove the 250-sheet controller card assembly. Go to **“250-sheet controller card assembly removal” on page 4-106.**
2. Remove the screw (A) securing the media size actuator to the 250-sheet frame.

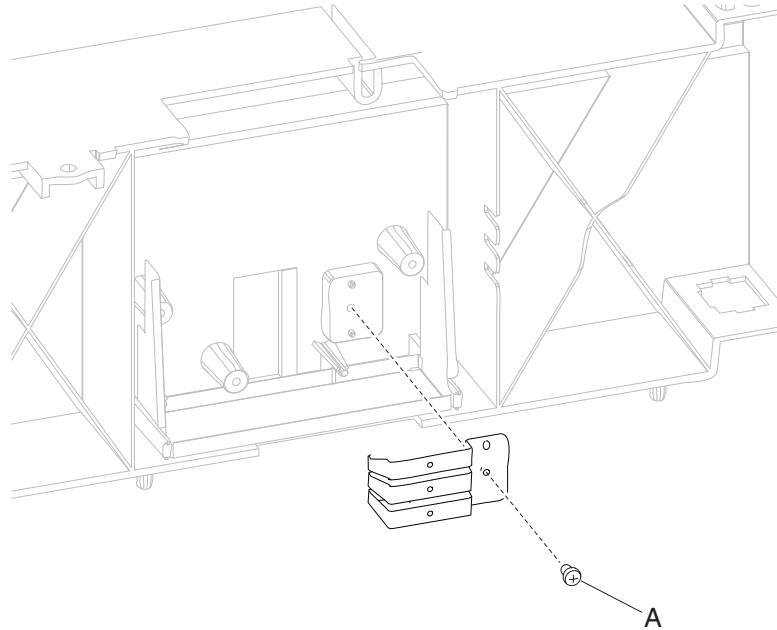

3. Remove the media size actuator.

## Media tray catch spring removal

1. Remove the 250-sheet frame assembly. Go to **“250-sheet frame assembly removal”** on page 4-104.
2. Turn the drawer upside down to access the media tray catch spring.
3. Release the media tray catch spring.

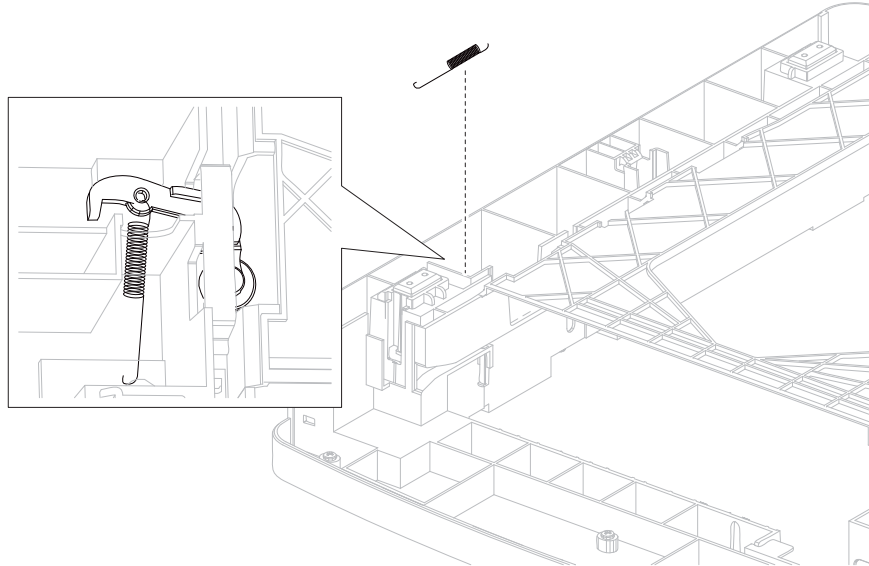

## Media out actuator removal (models T652 and T654)

1. Remove the 550-sheet pick arm bracket assembly. Go to **“550-sheet pick arm bracket assembly removal”** on page 4-108.
2. Release the hook (A) securing the media out actuator with spring to the 550-sheet pick arm bracket assembly.
3. Detach the spring (B) from the media out actuator.

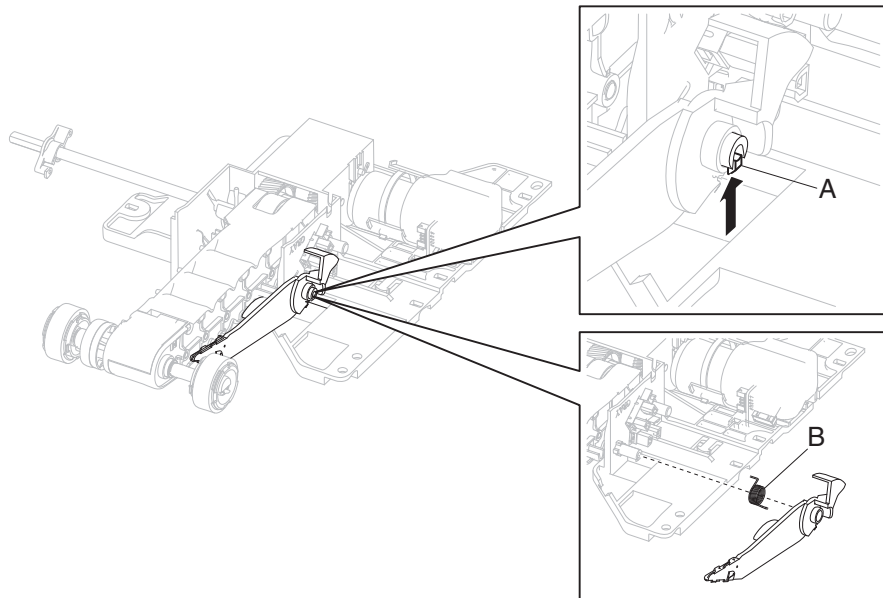

## Media size actuator removal

1. Remove the 550-sheet controller card assembly. Go to **“550-sheet controller card assembly removal” on page 4-111.**
2. Remove the screw (A) securing the media size actuator to the 550-sheet frame.

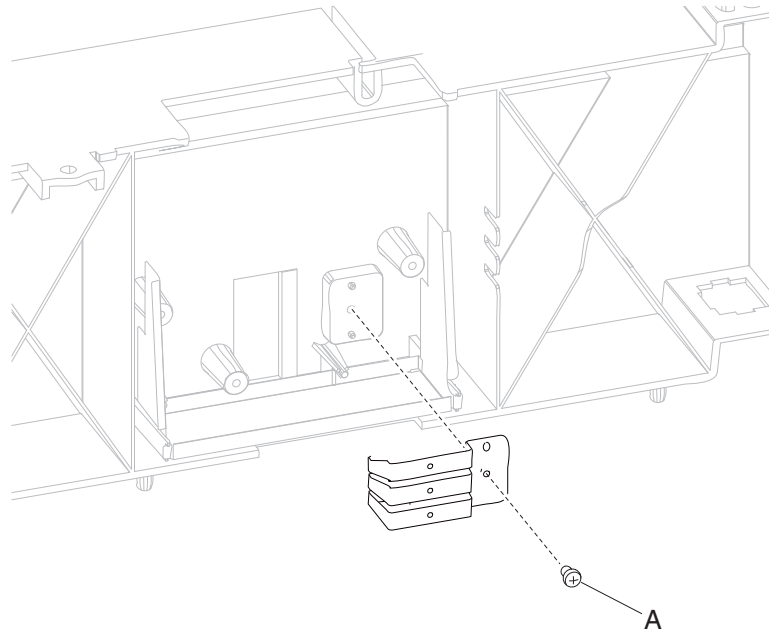

3. Remove the media size actuator.

## Media tray catch spring removal

1. Remove the 550-sheet frame assembly. Go to **“Media size actuator removal” on page 4-159.**
2. Turn the drawer over so that you can access the media tray catch spring.
3. Release the media tray catch spring.

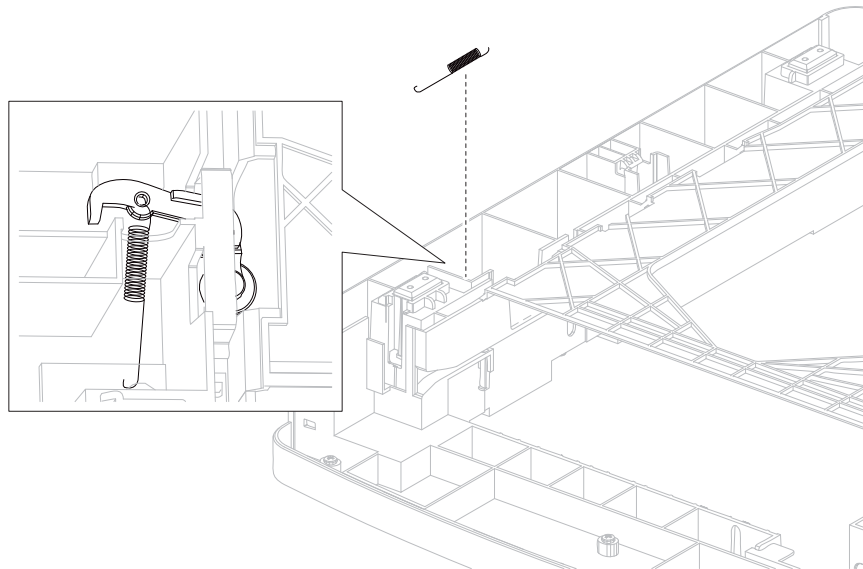

## Media tray roller catch assembly removal

1. Remove the media tray catch spring. Go to **“Media tray catch spring removal”** on page 4-159.
2. Remove the tray roller catch assembly from the drawer.

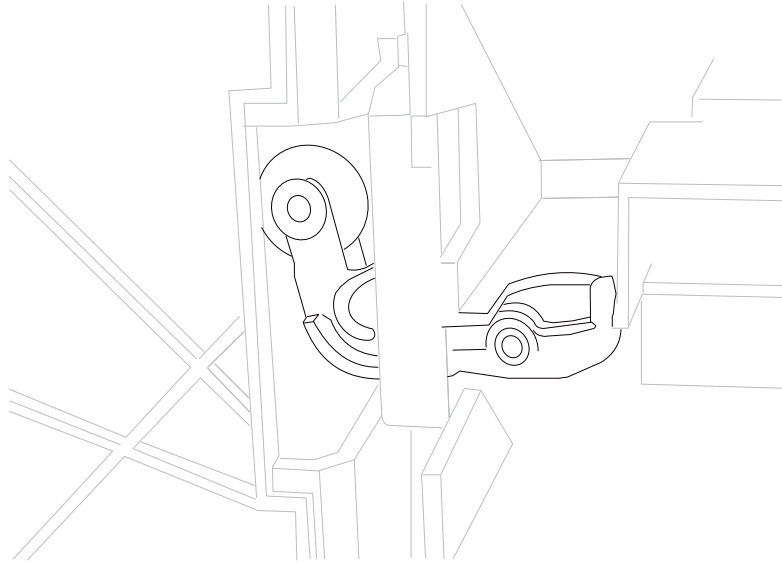

## Output expander rear door assembly removal

1. Open the rear door assembly.
2. Hold the door to approximately 45° angle, and force out the left hinge and slide the right hinge out to remove the door.

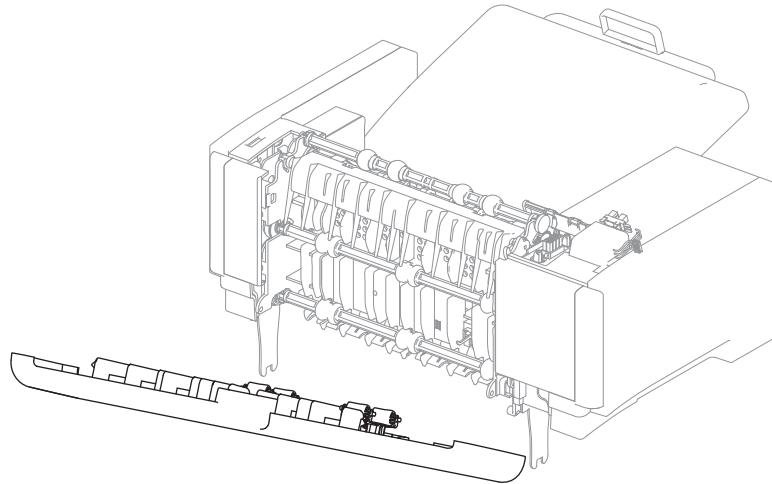

## Output expander left outer cover removal

1. Remove the output expander rear door assembly. Go to **“Output expander rear door assembly removal” on page 4-161.**
2. Grasp the lower rear corner of the left outer cover and pull out to remove.

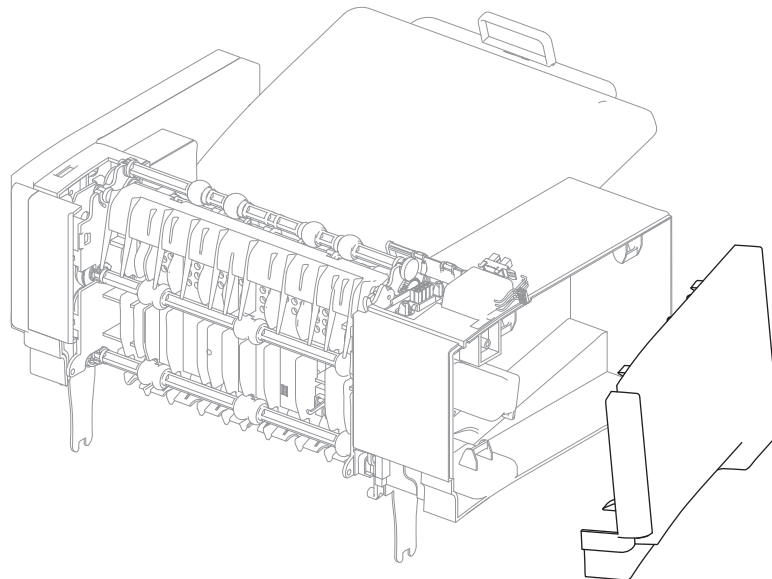

## Output expander left inner cover removal

1. Remove the output expander left outer cover. Go to **“Output expander left outer cover removal” on page 4-161.**
2. Remove the screw (A) securing the left inner cover.

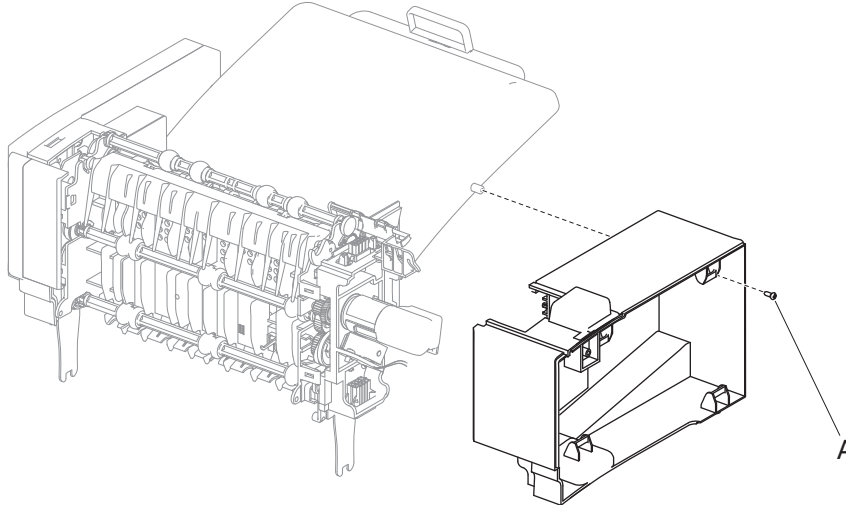

3. Holding the rear of the left inner cover, pull out while simultaneously separating it from the option.

## Output expander right outer cover removal

1. Remove the output expander rear door assembly. Go to **“Output expander rear door assembly removal” on page 4-161.**
2. Grasp the lower rear corner of the right outer cover and pull out to remove.

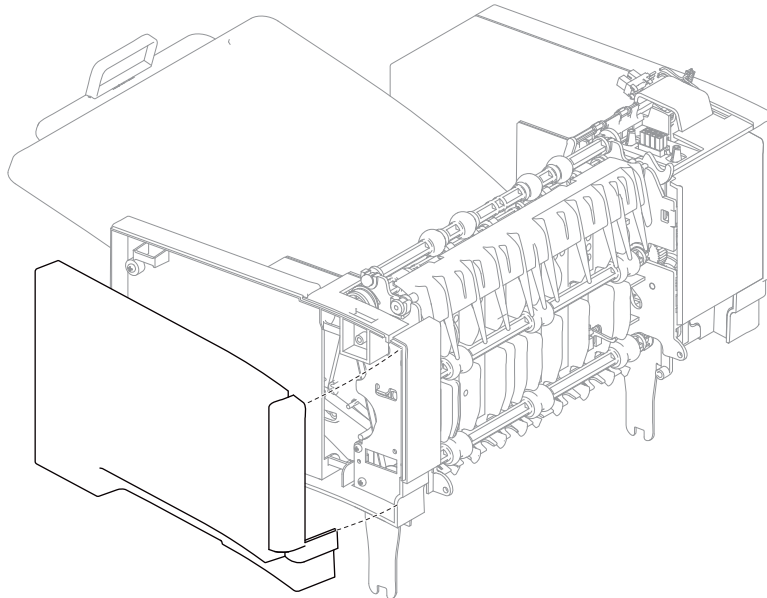



## Output expander right inner cover removal

1. Remove the output expander right outer cover. Go to **“Output expander right outer cover removal” on page 4-162.**
2. Remove the screw (A) securing the right inner cover to the unit.

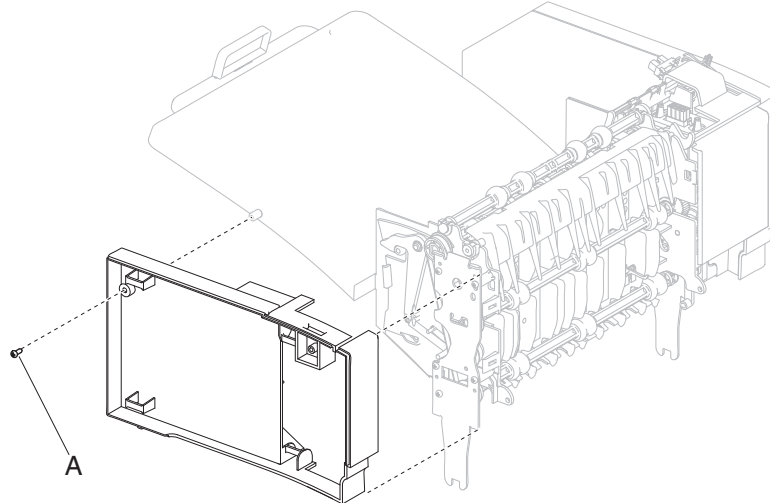

3. At the rear of the right inner cover, pull out from the option and remove the right inner cover.

## Output expander media bin latch (left and right) removal

1. Remove the output expander left or right inner cover. Go to **“Output expander left inner cover removal” on page 4-162** or **“Output expander right inner cover removal” on page 4-163.**
2. If removing the right side media bin latch, use a springhook to pull the media bin latch spring off the spring post on the output expander frame.
3. If removing the left side media bin latch, just pull out on the bottom of the latch and pull the top off the boss.
4. Pull the media bin latch from its boss to remove.

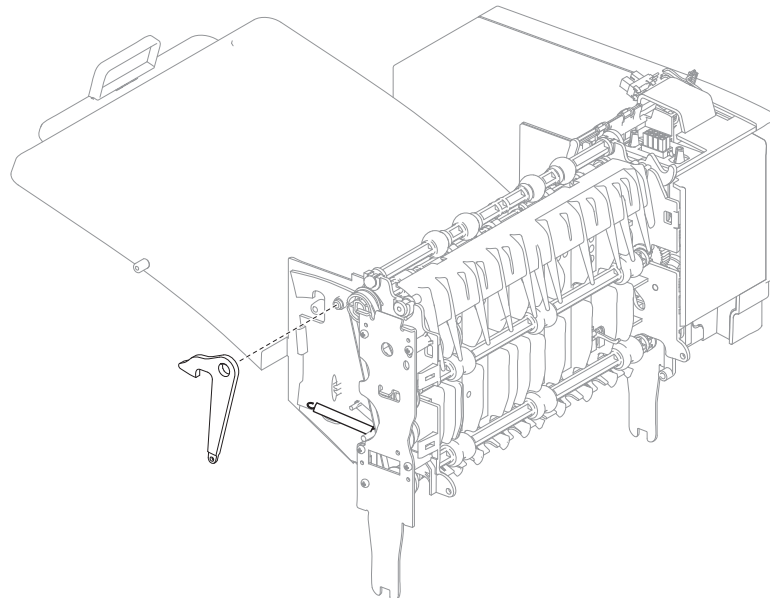

## Output expander media output bin assembly removal

1. Remove the left and right output expander media bin latches. Go to **“Output expander media bin latch (left and right) removal” on page 4-163.**
2. Remove the standard output bin LED. Go to **“Output expander sensor (pass through) removal” on page 4-169.**
3. Rotate the output bin assembly downward and out of the slots to remove.

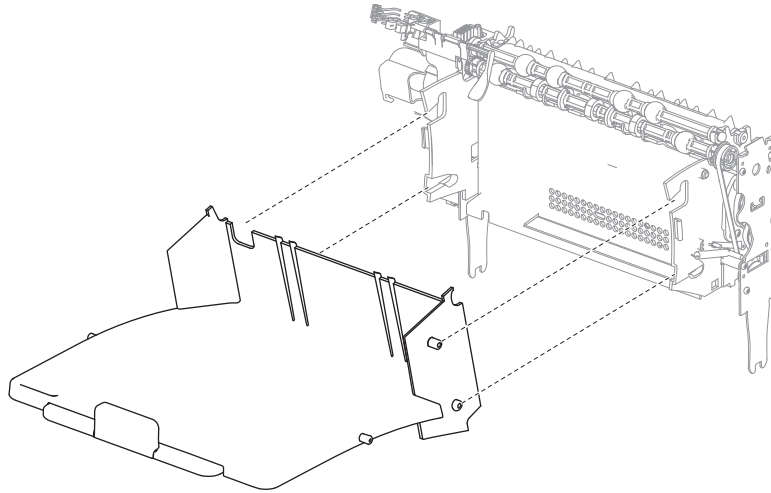

## Output expander media bin full actuator removal

1. Remove the output expander left inner cover. Go to **“Output expander left inner cover removal” on page 4-162.**
2. Unsnap the actuator from its hinges and pull out to remove.

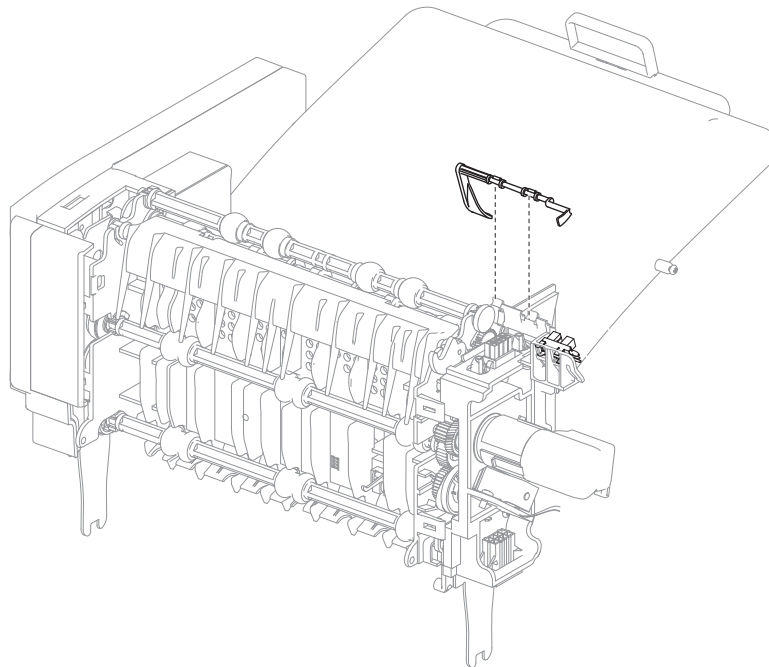

## Output expander sensors (media bin full) assembly removal

1. Remove the output bin left inner cover. Go to **“Output expander left inner cover removal” on page 4-162.**
2. Untwist the sensor harnesses from the cable guide.
3. Release the tabs securing the sensors (media bin full) and remove.

**Replacement Note:** Be sure to replace the sensors in the correct order. Make sure their positions are not switched.

4. Remove the output expander controller card cover panel. Go to **“Output expander controller card cover panel removal” on page 4-166.**
5. Disconnect the sensor (media bin full) harness from the controller card and remove.

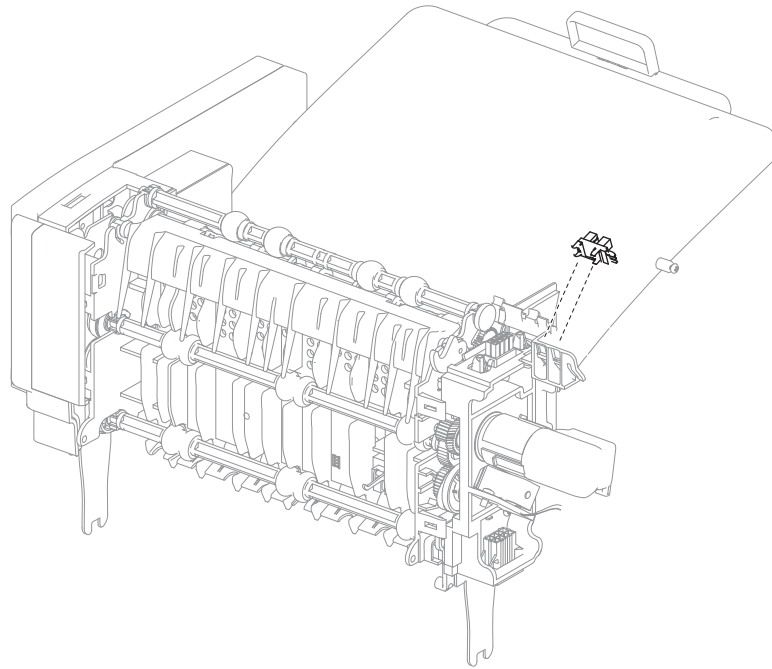

## Output expander sensor (media bin full) bracket assembly removal

1. Remove the output expander left inner cover. Go to **“Output expander left inner cover removal” on page 4-162.**
2. Grasp the sensor bracket and pull away from the option while releasing the tab.

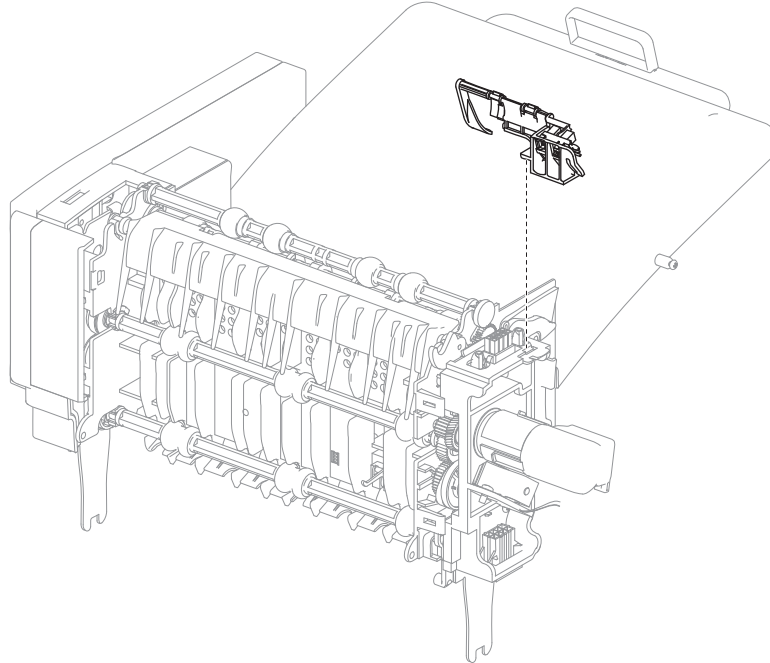

3. If replacing the bracket, remove the sensors (media bin full) from the bracket.

**Replacement Note:** Be sure to replace the sensors in the correct order. Make sure their positions are not switched.

## Output expander controller card cover panel removal

1. Remove the output expander media output bin assembly. Go to **“Output expander media output bin assembly removal” on page 4-164.**

2. Remove the screw (A) on the back side of the option.

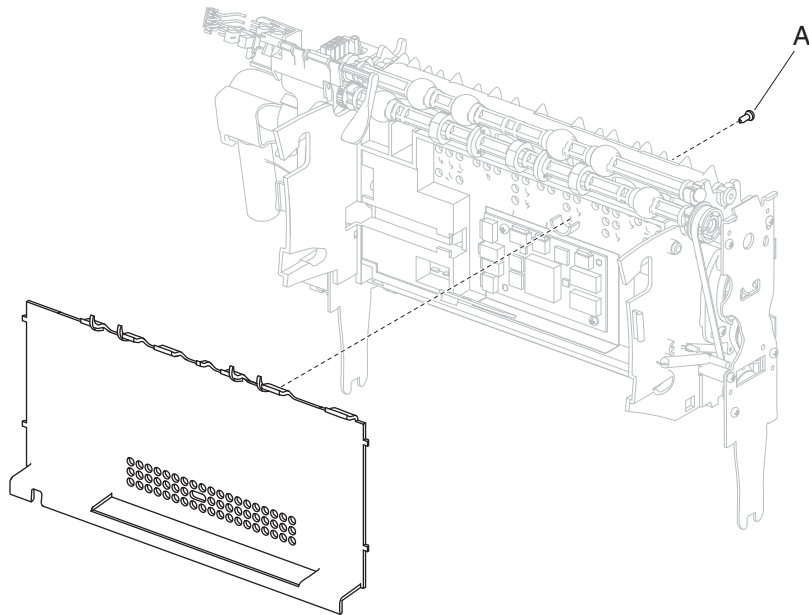

3. Remove the grounding screw (B) on the right output option frame guide the grounding cable through the hole in the frame.
4. Carefully flex the panel from the lower middle and pull the four tab (C) out of the frame and remove.

## Output expander controller card removal

1. Remove the output expander controller card cover panel. Go to **“Output expander controller card cover panel removal” on page 4-166.**
2. Disconnect all harnesses from the controller card.
3. Remove the two screws (A) securing the controller card to the frame.

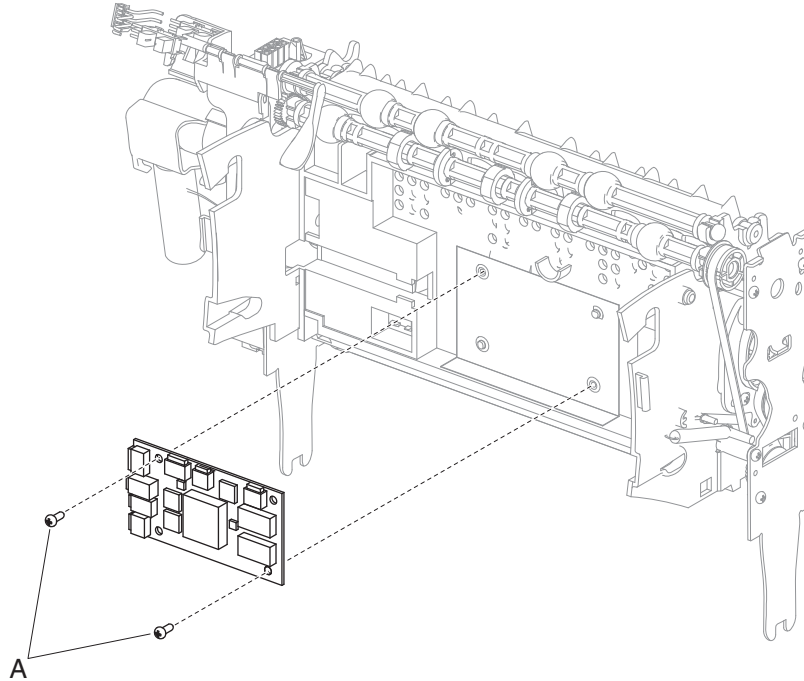

4. Remove the controller card.

**Replacement Note:** Be sure to replace the interface connectors in their proper orientation as the two have common connection pins.

## Output expander sensor (pass through) removal

1. Remove the output expander controller card cover panel. Go to **“Output expander controller card cover panel removal” on page 4-166.**
2. Release the tabs securing the sensor (pass through).
3. Remove the sensor harness from the controller card.
4. Pull the connector harness through the frame and remove.

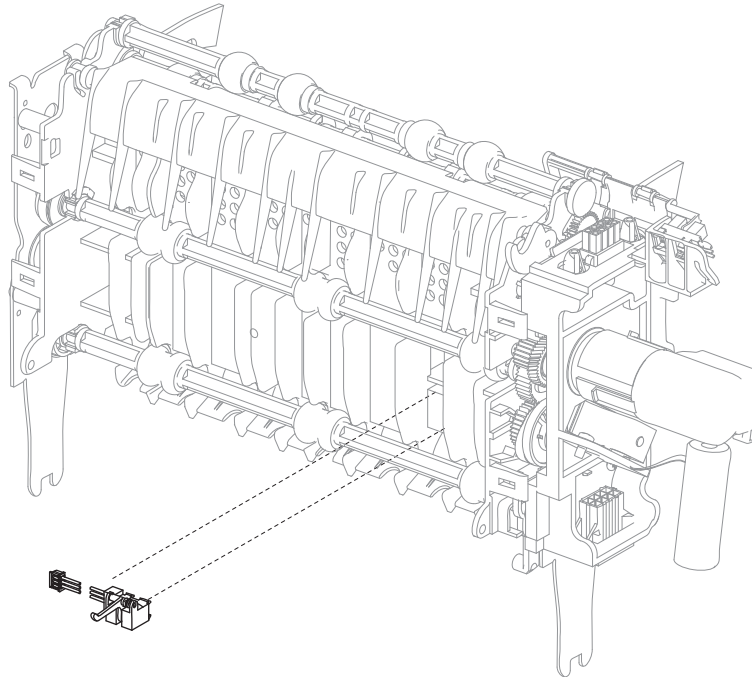

## Output expander deflector gate removal

1. Use a spring hook to disconnect the upper end of the deflector gate spring.
2. Temporarily hook the upper end of the deflector gate spring to the left frame.
3. Pull the deflector gate out of its hinges and remove.

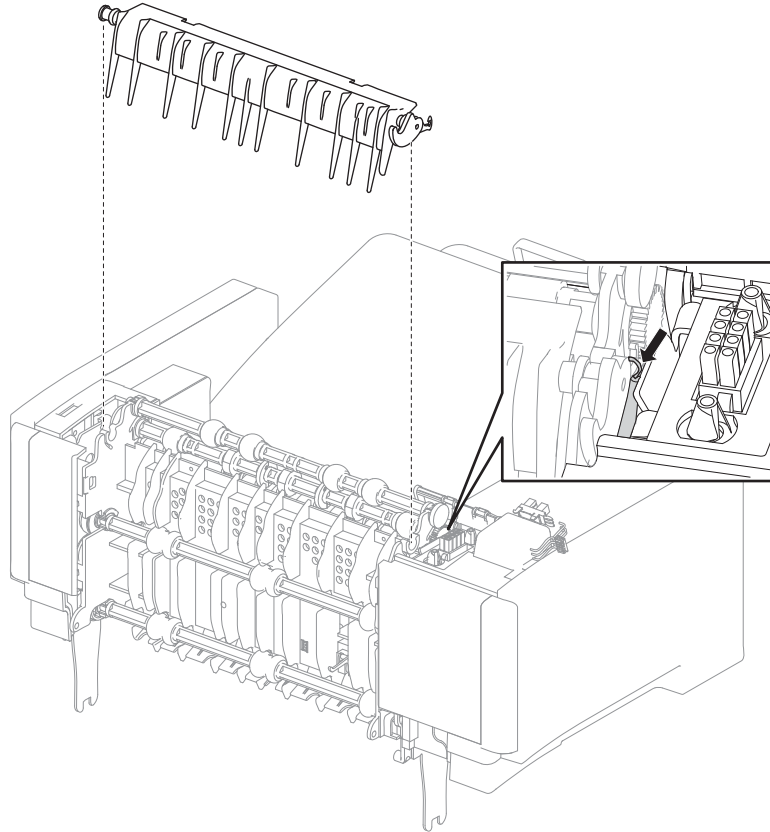



## Output expander sensor (deflector gate HP) removal

1. Remove the output expander left inner cover. Go to **“Output expander left inner cover removal”** on **page 4-162**.
2. Remove the four screws securing the left frame assembly to the option.
3. Pull the left frame assembly out far enough to gain access to the sensor (deflector gate HP).
4. Release the tabs securing the sensor (deflector gate HP) and remove.
5. Disconnect the harness to the sensor and remove.

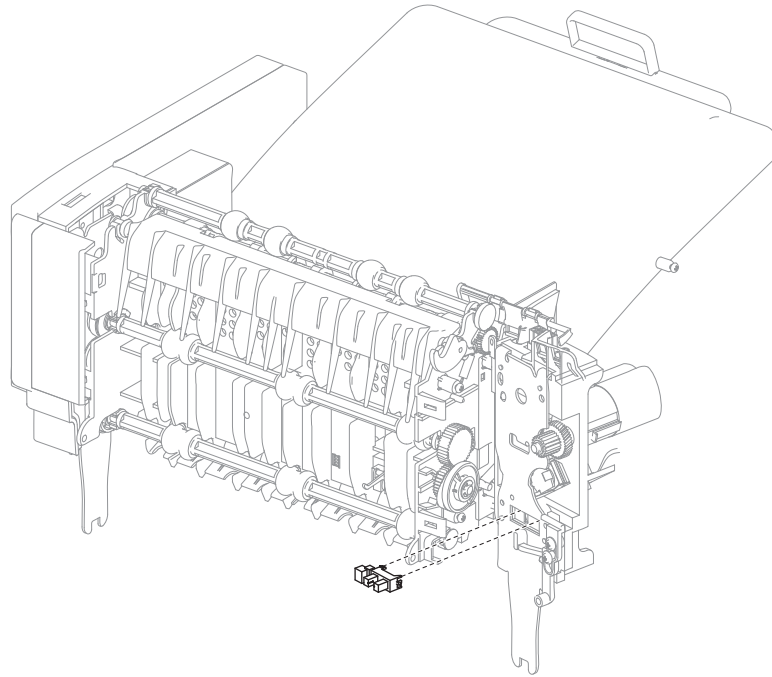

## SFP stapler assembly rear door assembly removal

1. Open the rear door assembly.
2. Force the left hinge out of the slot by pushing the door to the right.
3. Once the left hinge has been disengaged, pull the right hinge out.
4. Remove the rear door assembly.

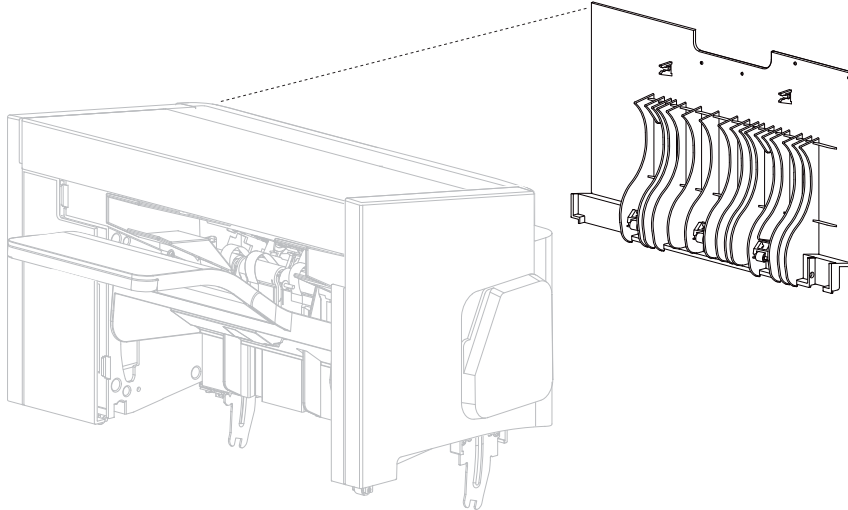

## SFP stapler assembly right cover removal

1. Remove the two screws (A) on the inside of the exit bin compartment securing the right cover.

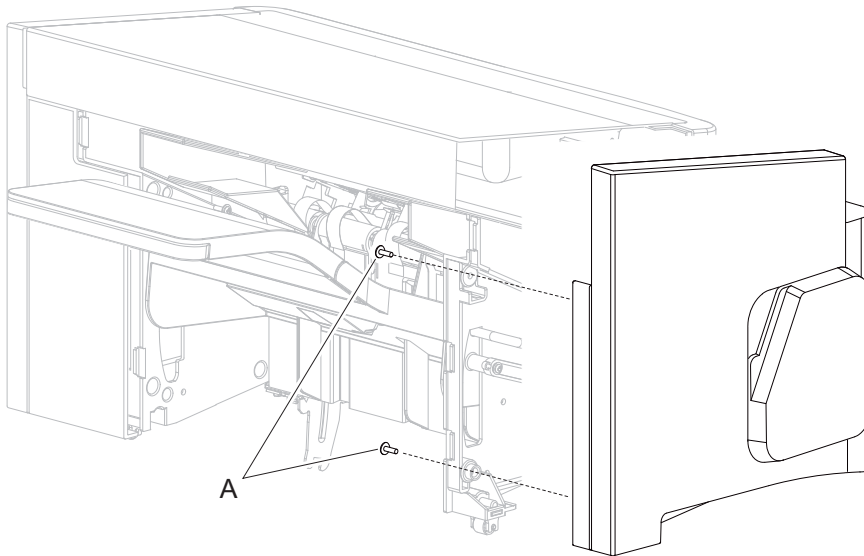

2. Pull out on the front side of the right cover to disengage the tabs.
3. Remove the right cover.

## SFP stapler assembly left cover removal

1. Remove the two screws (A) on the inside of the exit bin compartment securing the left cover.

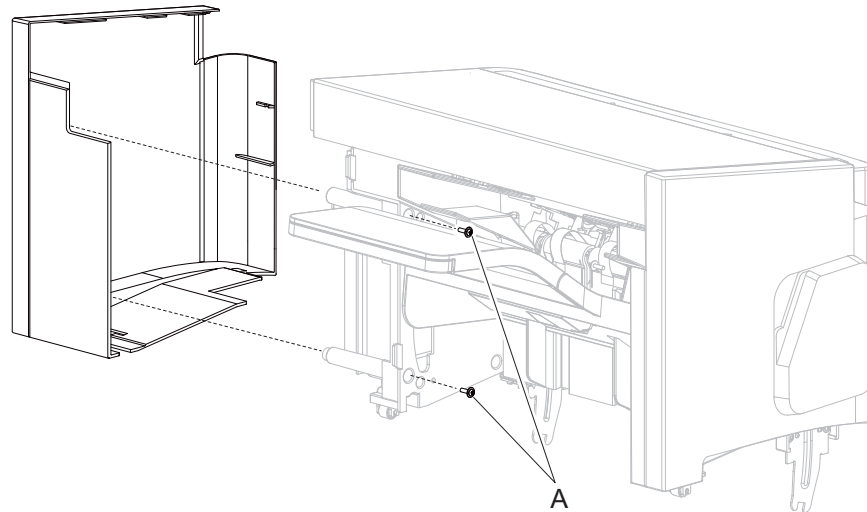

2. Pull out on the front side of the left cover to disengage the tabs.
3. Remove the left cover.

## SFP stapler assembly top cover removal

1. Remove the left and right cover. Go to **“SFP stapler assembly left cover removal”** on page 4-173 and **“SFP stapler assembly right cover removal”** on page 4-172.
2. Remove the two screws (A) from the left and right side of the top cover.

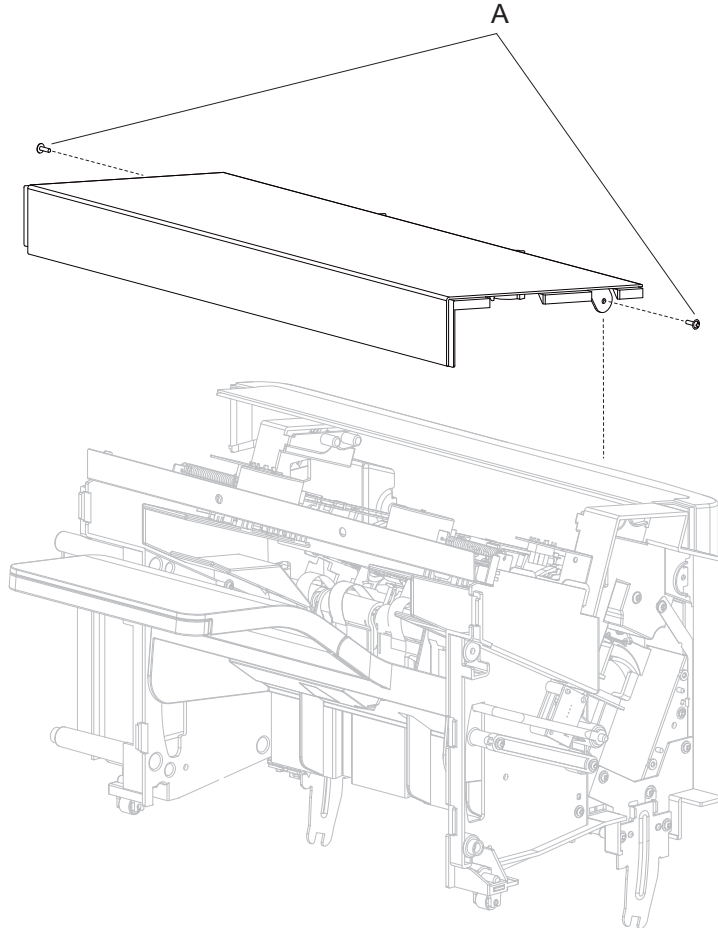

3. Pull up and toward the front to remove the top cover.

## SFP stapler assembly handle cover removal

1. Remove the left and right cover. Go to **“SFP stapler assembly left cover removal”** on page 4-173 and **“SFP stapler assembly right cover removal”** on page 4-172.
2. Remove two screws (A) from each side of the SFP stapler assembly.

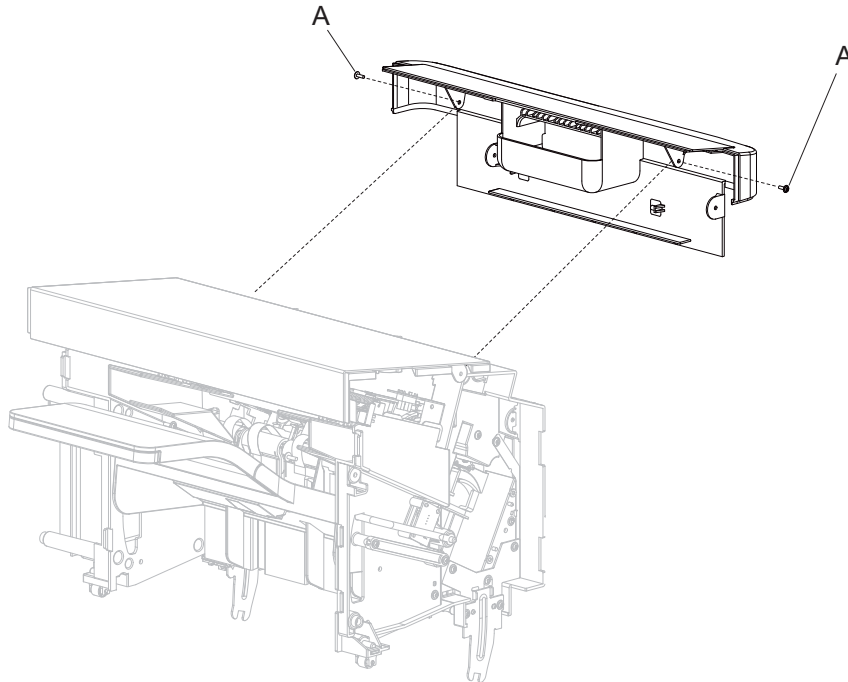

3. Lift up and to the rear to remove the cover.

## SFP stapler assembly LED sensor cover removal

1. Remove the screw (A) securing the LED sensor cover to the underside of the output bin.

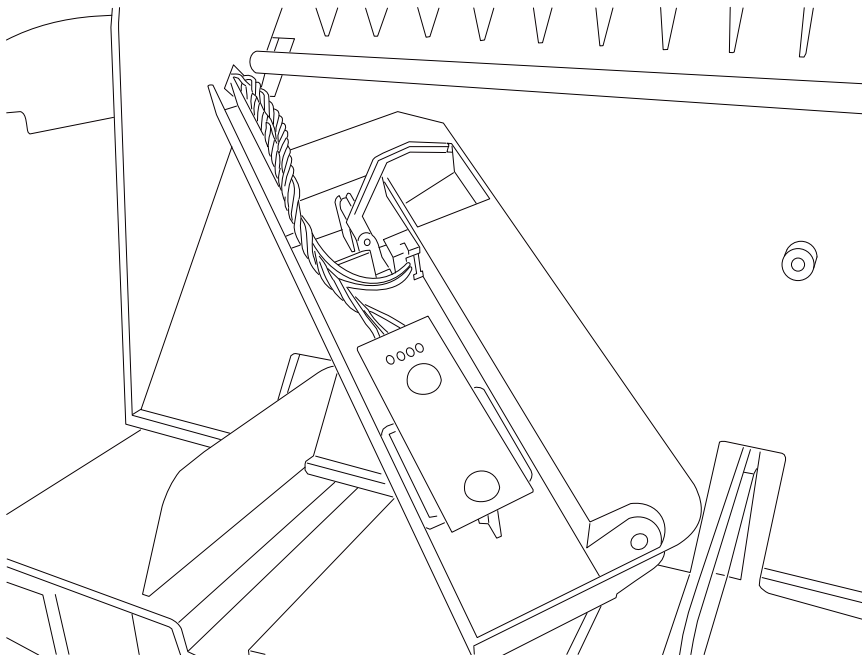
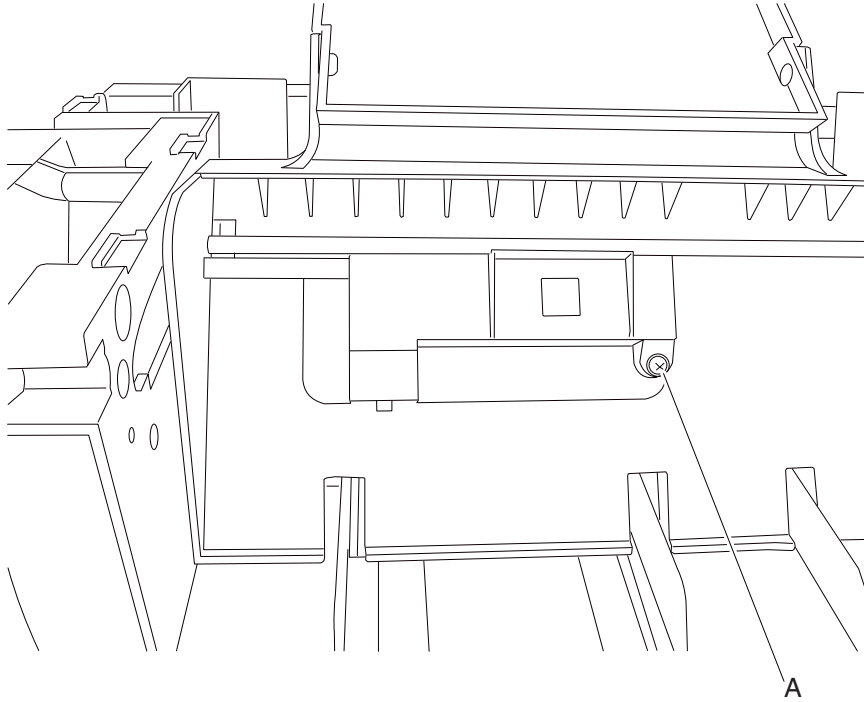

2. Remove the output bin LED. Go to **“SFP stapler assembly standard output bin LED and LED clear lens removal” on page 4-178.**
3. Remove the sensor (finisher bin media present). Go to **“SFP stapler assembly sensor (finisher bin media present) removal” on page 4-177**

4. Remove the LED sensor cover.

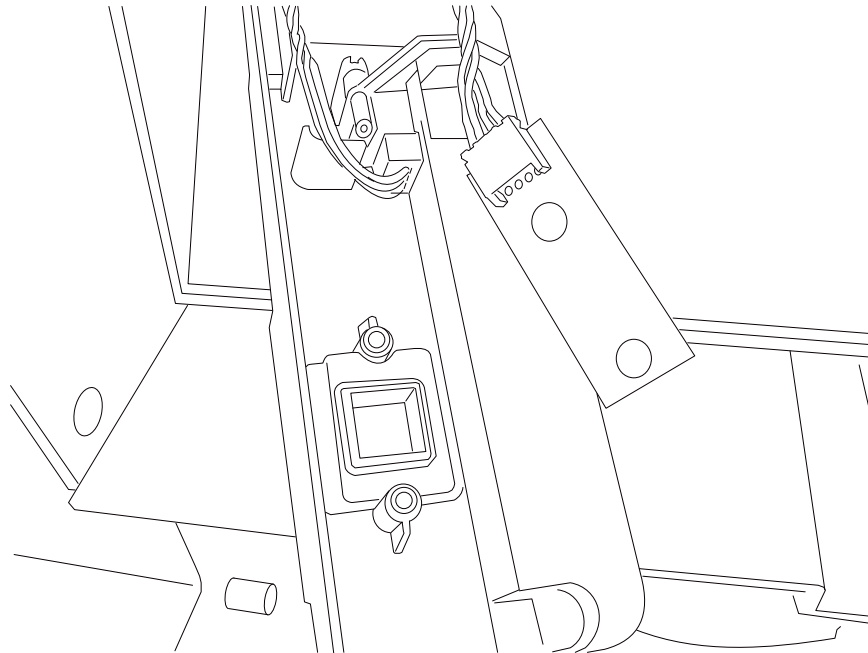

### SFP stapler assembly sensor (finisher bin media present) removal

1. Remove the LED sensor cover. Go to **“SFP stapler assembly LED sensor cover removal”** on **page 4-176**.
2. Using a flat-blade screwdriver, release the tabs (A) on the sensor and remove it from the sensor cover.

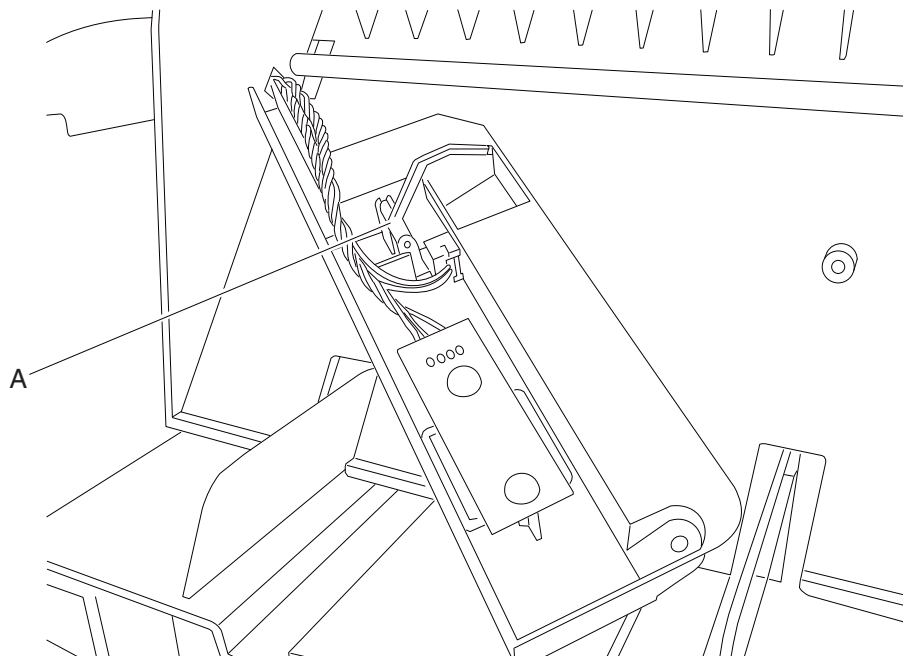

3. Remove the harness connected to the media bin present sensor.
4. Remove the sensor (finisher bin media present).

## SFP stapler assembly standard output bin LED and LED clear lens removal

1. Remove the LED sensor cover. Go to **“SFP stapler assembly LED sensor cover removal”** on **page 4-176**.
2. Remove the two screws (A) securing the LED to the cover.

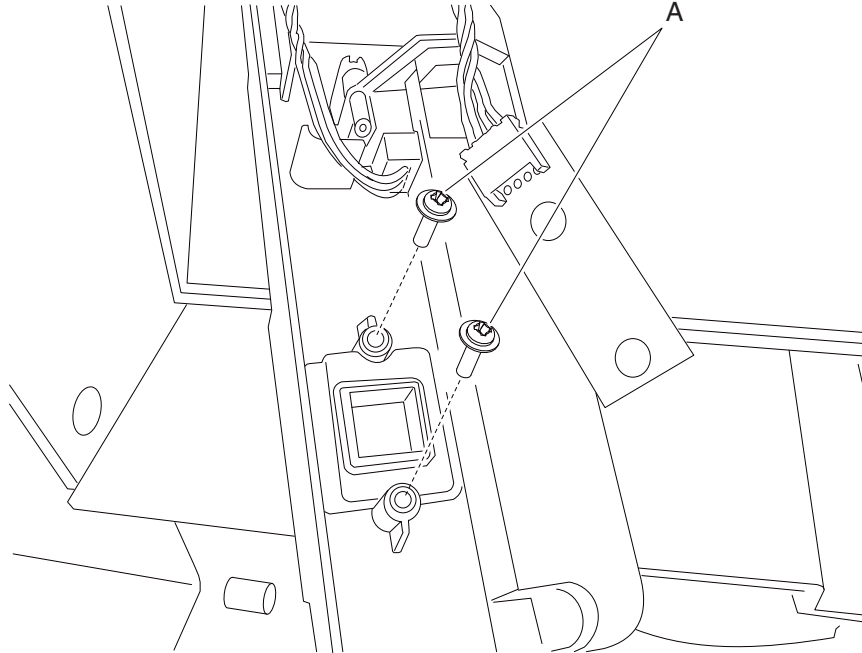

3. Remove the LED and disconnect the harness.
4. Remove the LED clear lens.



## SFP stapler assembly tamper drive belt removal

1. Remove the tamper recoil spring. Go to **“SFP stapler assembly tamper drive belt removal”** on **page 4-179**.
2. Pull the belt out the tamper belt holder and remove the belt from the pulley.

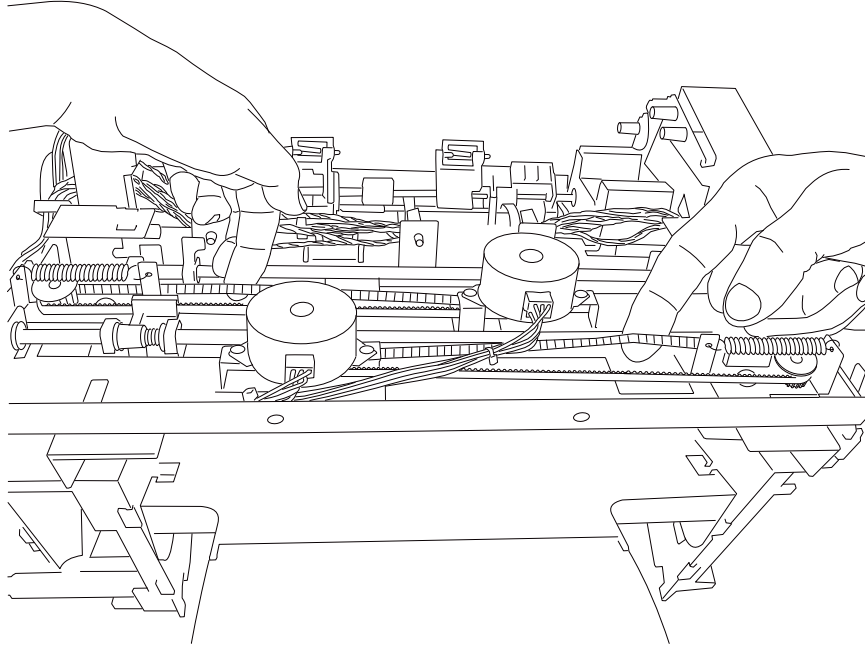

## SFP stapler assembly tamper drive motor assembly removal

1. Remove the top cover. Go to **"SFP stapler assembly top cover removal"** on page 4-174.
2. Pull slack in the tamper drive belt and remove the belt from the tamper drive belt pulley.
3. Disconnect the tamper driver motor harness from the controller card.
4. Remove the two screws (A) securing the tamper drive motor assembly to the tamper frame.

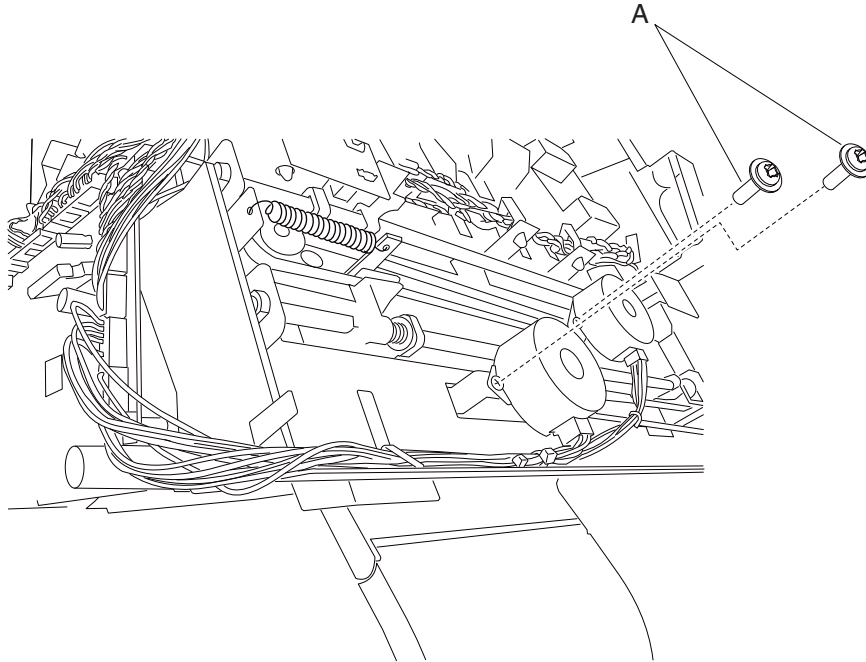

5. Remove the tamper drive motor assembly.

## SFP stapler assembly media stack flap and media stack flap actuator removal

1. Remove the handle cover. Go to **“SFP stapler assembly handle cover removal”** on page 4-175.
2. Release the locking tab and slide the media stack flap actuator to the right and remove.

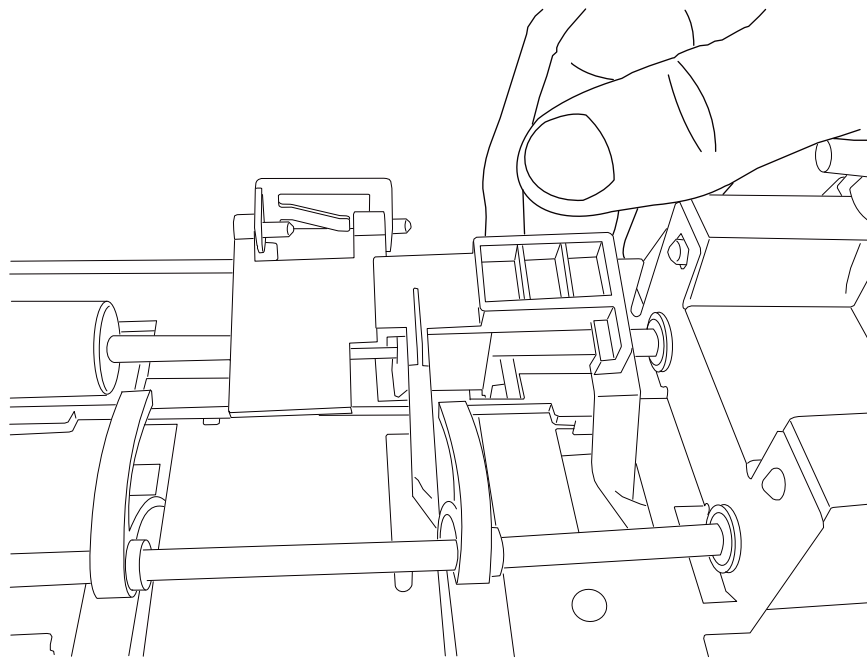
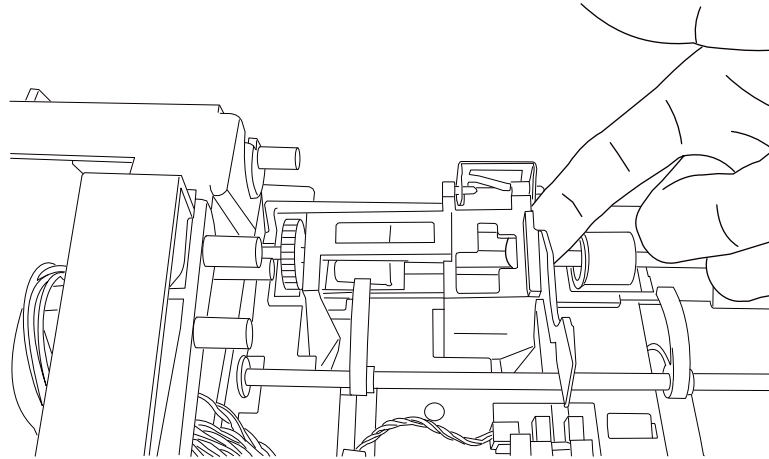

## SFP stapler assembly stapler unit assembly removal

1. Remove the right cover. Go to **“SFP stapler assembly right cover removal” on page 4-172.**
2. Remove the four cable harnesses attached to the stapler unit assembly.
3. Remove the three screws (A) securing the stapler unit assembly.

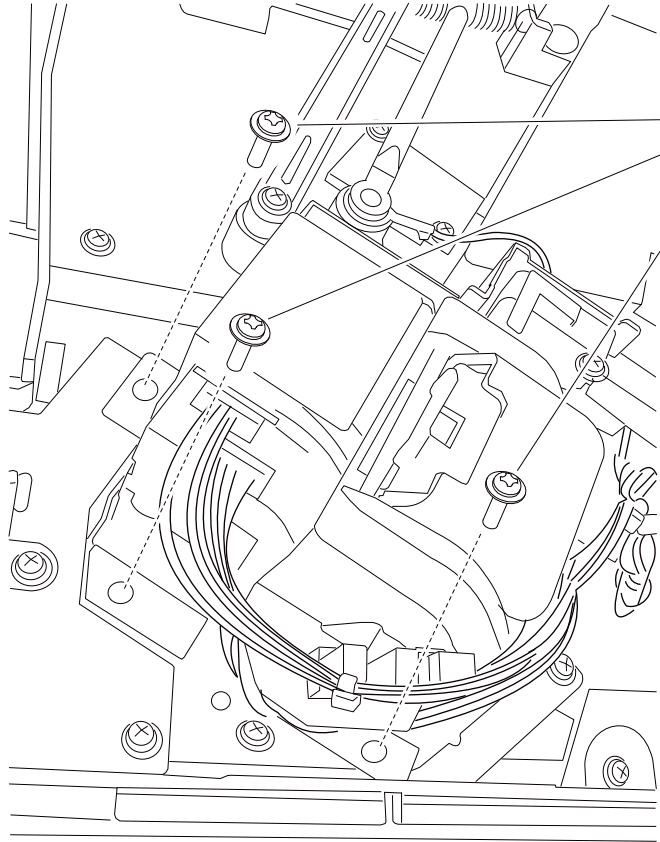

4. Remove the stapler unit assembly.

## SFP stapler assembly paddle drive motor assembly removal

1. Remove the left cover. Go to **“SFP stapler assembly left cover removal”** on page 4-173.
2. Disconnect the paddle motor harness from the controller card.
3. Remove the cable from the harness clip.
4. Remove the two screws (A) securing the two paddle drive motor assemblies.

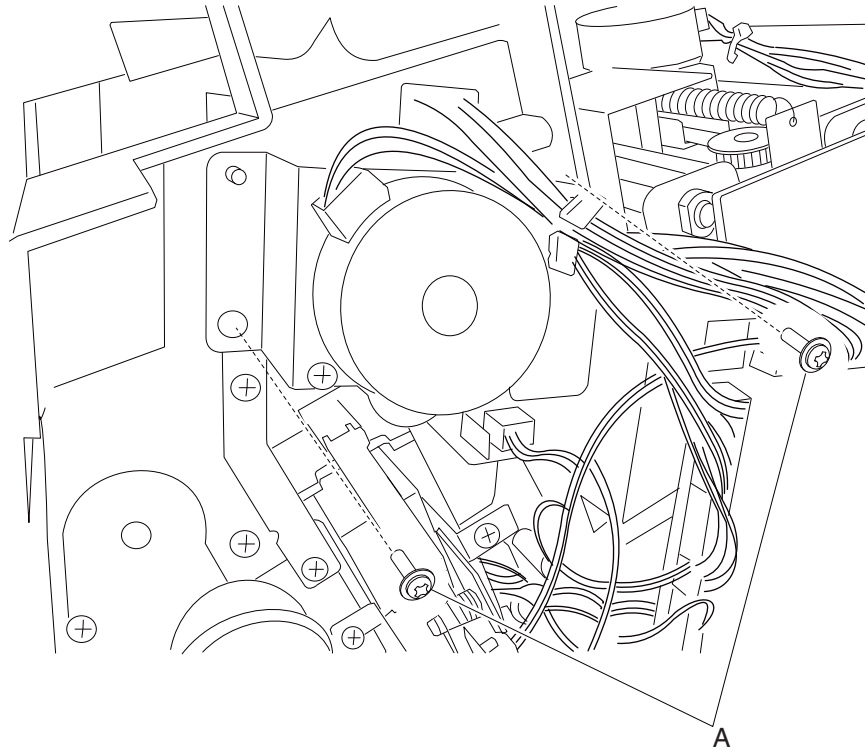

5. Remove the paddle drive motor assembly.

## SFP stapler assembly sensor (media stack) removal

1. Remove the top cover. Go to **"SFP stapler assembly top cover removal"** on page 4-174.
2. Disconnect the harness to the sensor (media stack).
3. Using your fingers, pinch tab (A) securing the sensor (media stack) and remove.

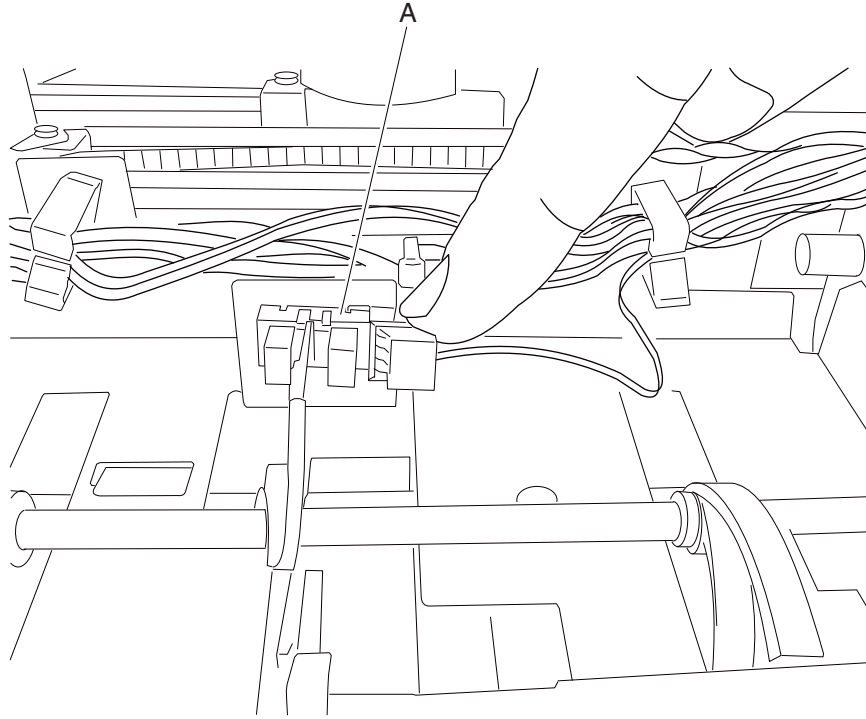

## SFP stapler assembly sensor (paddle HP) removal

1. Remove the left cover. Go to **“SFP stapler assembly left cover removal”** on page 4-173.
2. Disconnect the harness to the sensor (paddle home position).
3. Using your fingers, pinch tab (A) securing the sensor (paddle home position) and remove.

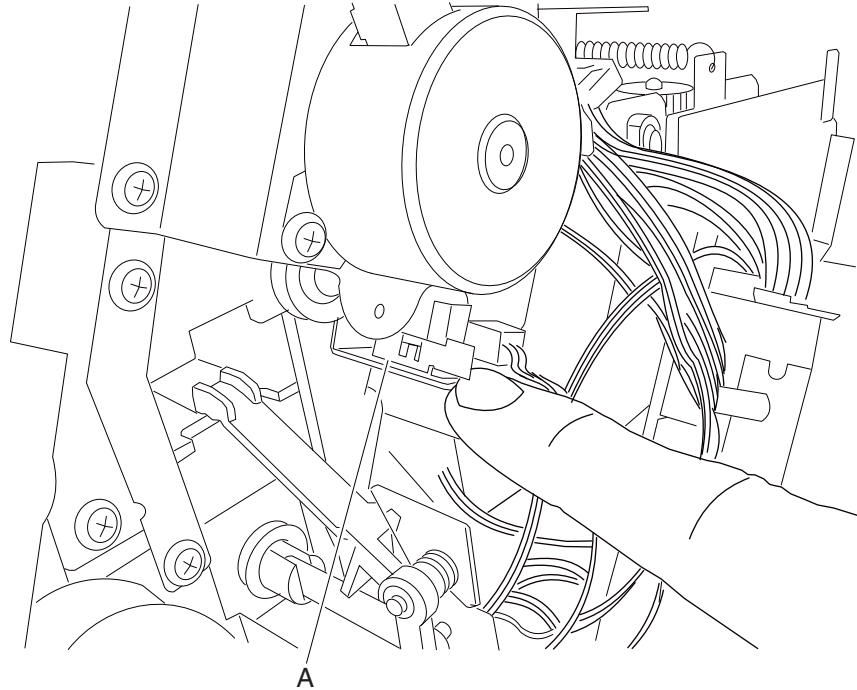

## SFP stapler assembly sensor (stapler access door interlock) removal

1. Remove the right cover. Go to **“SFP stapler assembly right cover removal” on page 4-172.**
2. Disconnect the harness to the sensor (stapler access door interlock).
3. Using your fingers, pinch tab (A) securing the sensor (stapler access door interlock) and remove.

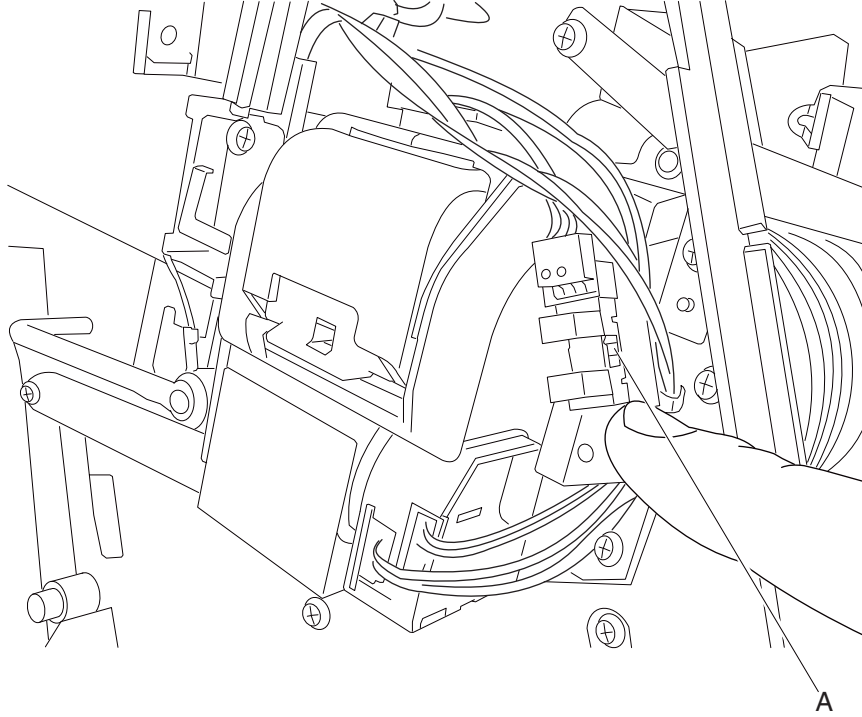



## SFP stapler assembly sensor (tamper HP left and right) removal

1. Remove the SFP stapler assembly top cover. Go to **"SFP stapler assembly top cover removal"** on **page 4-174**.
2. Disconnect the harness to the SFP stapler assembly sensor (tamper HP left and right).
3. Using your fingers, pinch the tabs (A) securing the staple finisher sensor (tamper HP left and right) and remove.

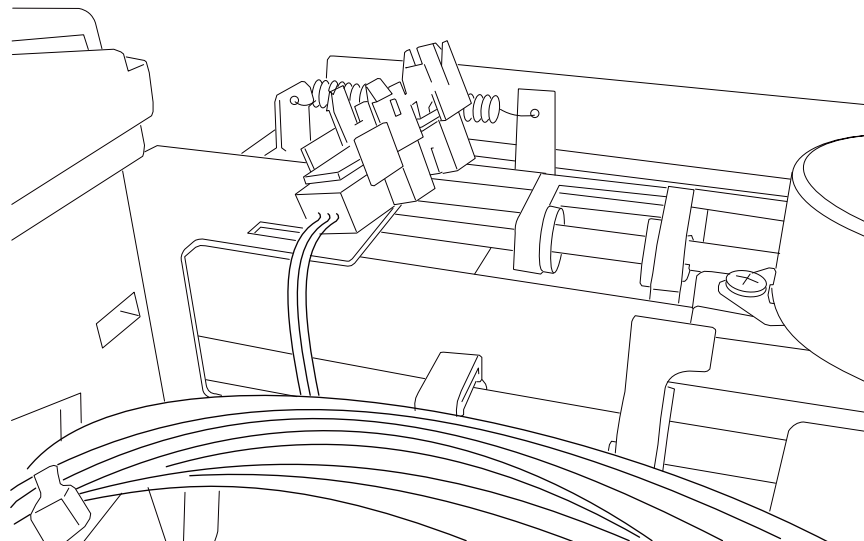
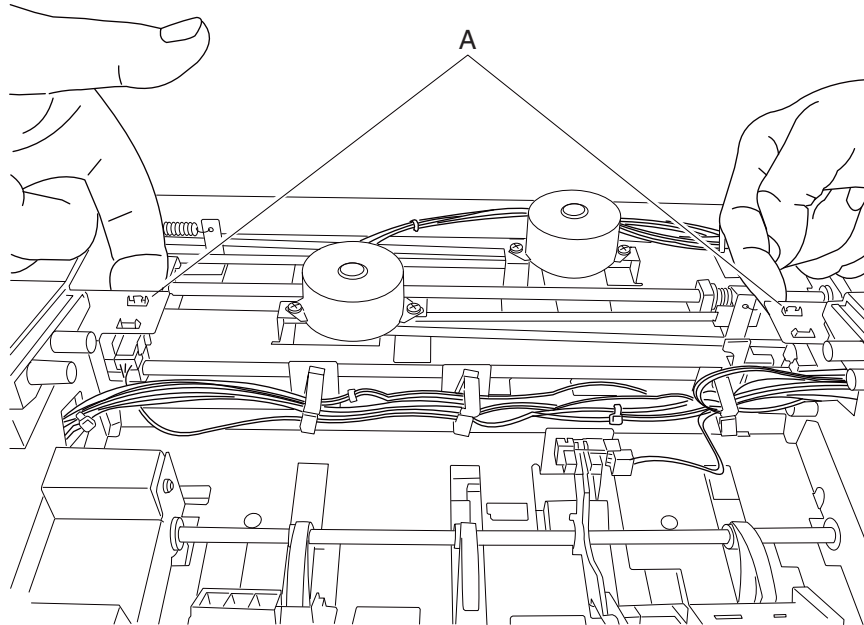

## SFP stapler assembly sensor (bin full send) removal

1. Remove the stapler/stacker controller card assembly. Go to **“Stapler/stacker controller card assembly removal” on page 4-192.**
2. Remove the two screws (A) securing the staple finisher sensor (bin full send).

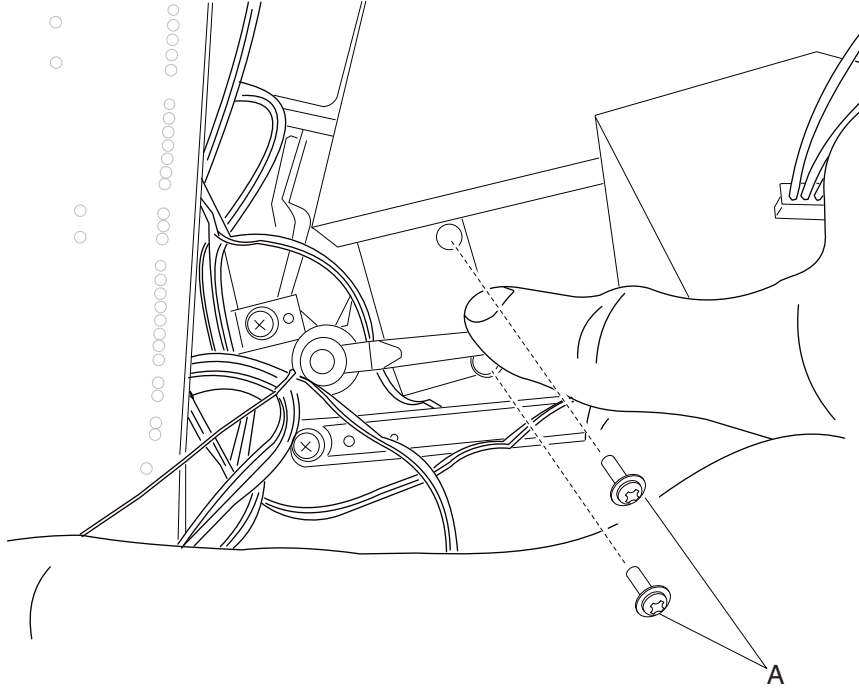

3. Disconnect the harness and remove.

## SFP stapler assembly sensor (bin full receive) removal

1. Remove the right cover. Go to **“SFP stapler assembly right cover removal”** on page 4-172.
2. Remove the two screws (A) securing the sensor (bin full receive).

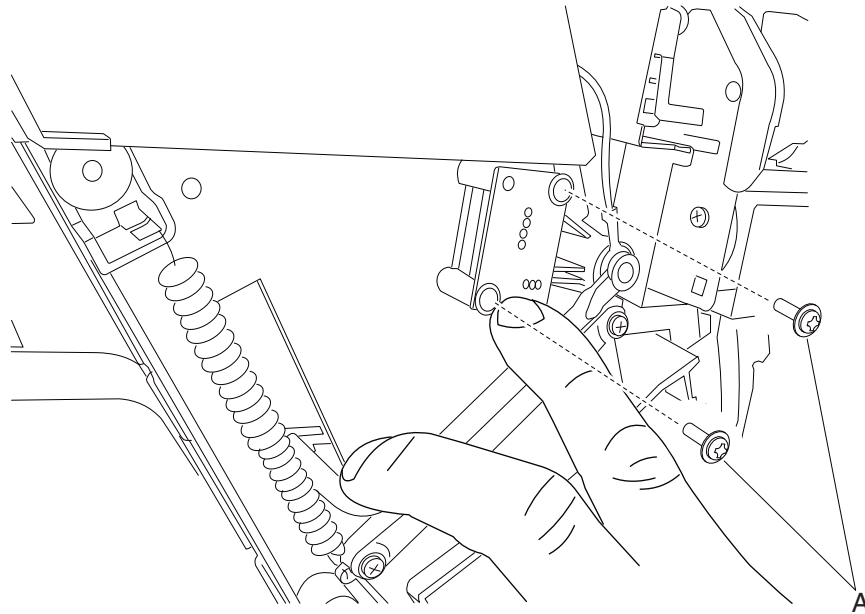

3. Disconnect the harness and remove.

## SFP stapler assembly sensor (media in stapler) removal

1. Remove the stapler unit assembly from the. Go to **“SFP stapler assembly stapler unit assembly removal”** on page 4-182.
2. Using a flat-blade screwdriver, release the tabs (A) securing the sensor.

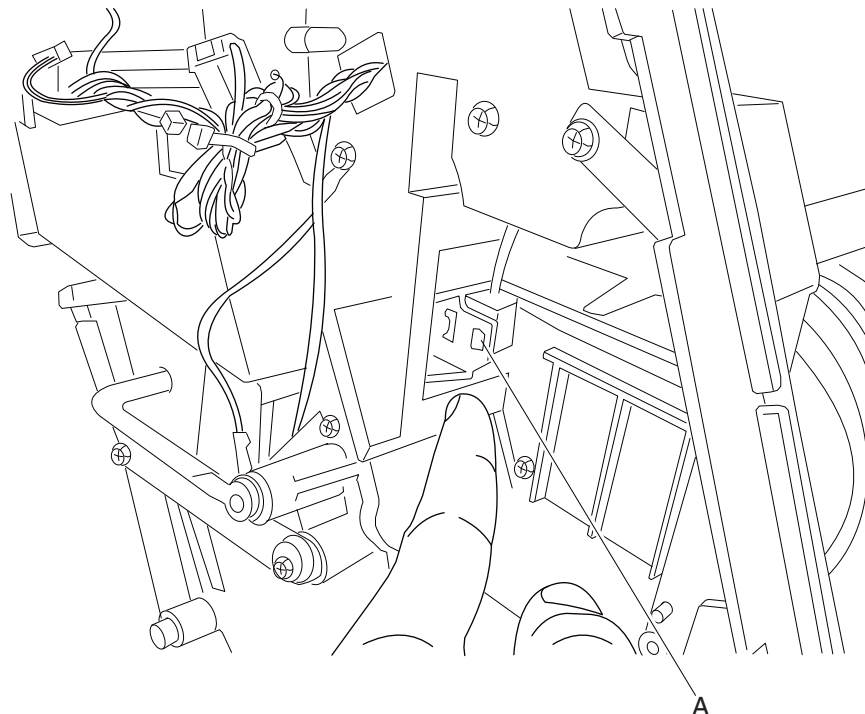

3. Using needlenose pliers, carefully grip the sensor and pull it out and disconnect the harness.

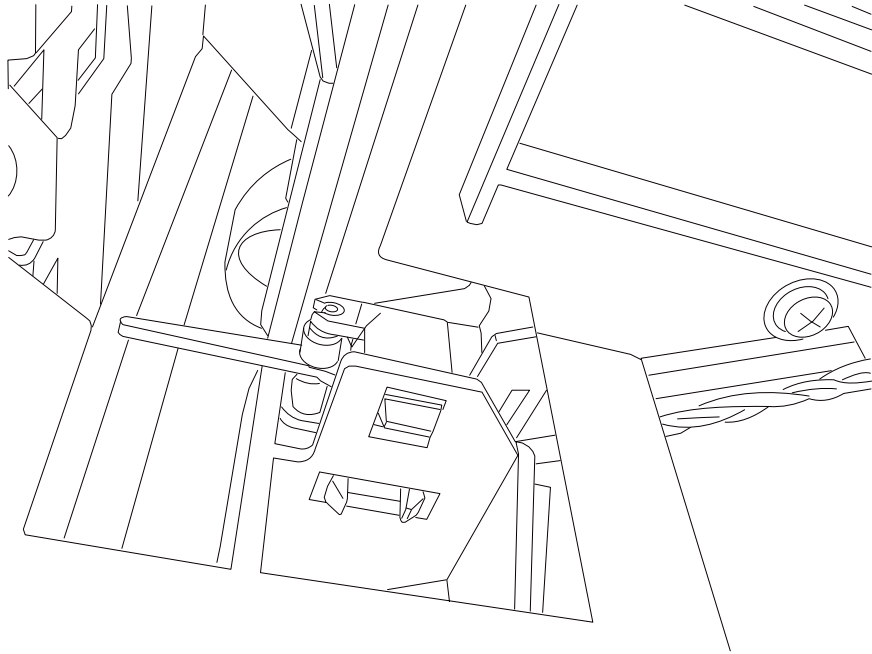

**Replacement Notes:** Using needlenose pliers, place the rear most tab in the sensor bracket first. Then push on the rear face of the sensor until the other two tabs snap into place.

### SFP stapler assembly sensor (deflector HP) removal

1. Remove the left cover. Go to **“SFP stapler assembly left cover removal”** on page 4-173.
2. Disconnect the harness to the sensor (deflector HP).

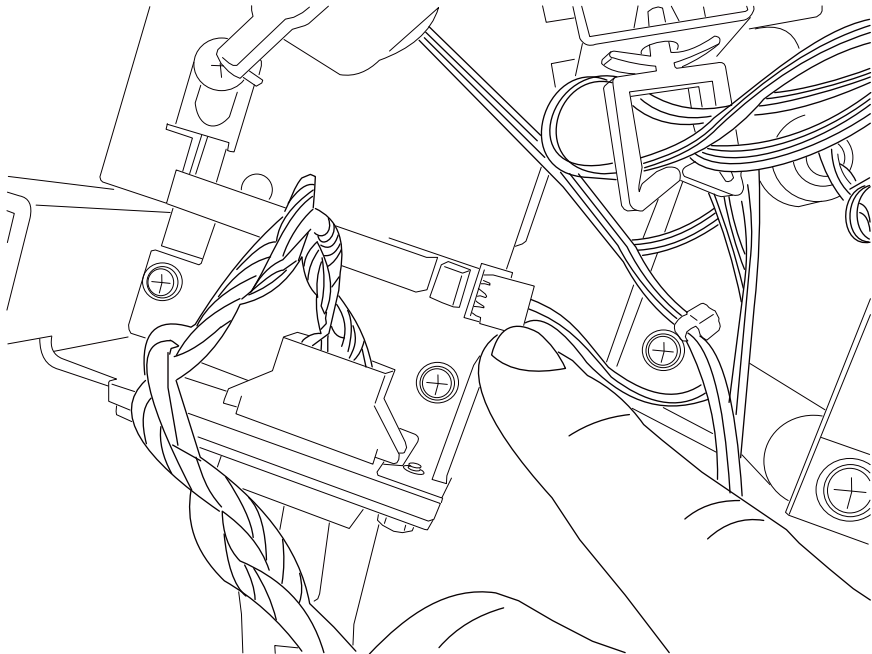

3. Release the tabs (A) securing the sensor to the unit.

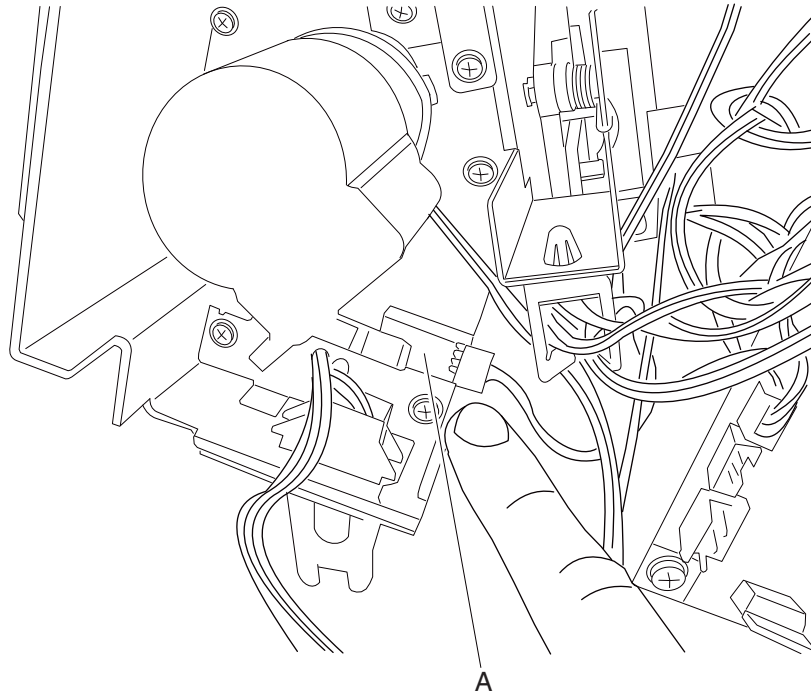

**Note:** The tabs may be difficult to access. The use of a spring hook or flat-blade screwdriver may be necessary to release the tabs.

## Stapler/stacker controller card assembly removal

1. Remove the left cover. Go to **“SFP stapler assembly left cover removal” on page 4-173.**
2. Disconnect all harnesses to the controller card.
3. Remove the three screws (A) securing the stapler/stacker controller card assembly.

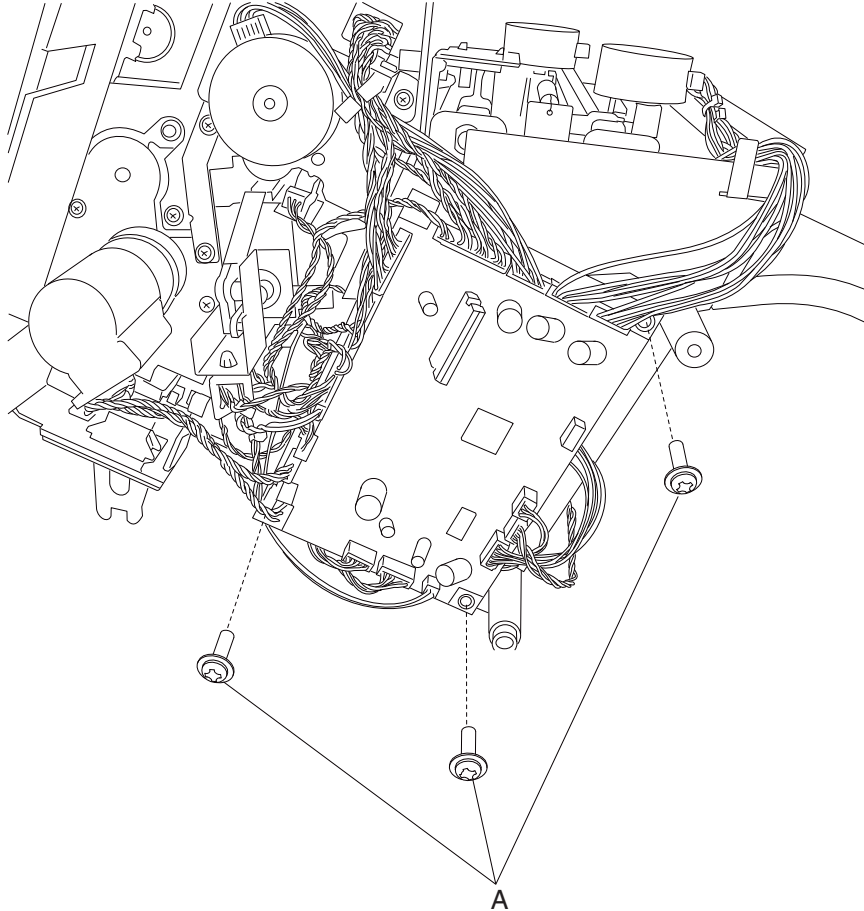

4. Remove the stapler/stacker controller card assembly.

## Sensor (HCIT tray raised HP) with cable assembly removal

**Note:** Carefully remove the base machine from the HCIT tray assembly before proceeding.

1. Remove the HCIT cover, left. Go to **“High capacity input tray (HCIT) cover, left removal” on page 4-122.**

2. Disconnect the sensor (HCIT tray raised HP) cable connector from the HCIT controller card assembly.

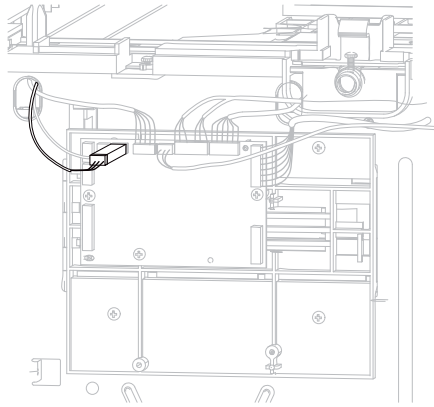

**Note:** Remove the cable from the restraints, and observe the routing for reinstallation.

3. Remove the screw (A) securing the sensor to the rear frame.
4. Release the hooks (B) securing the sensor to the rear frame.

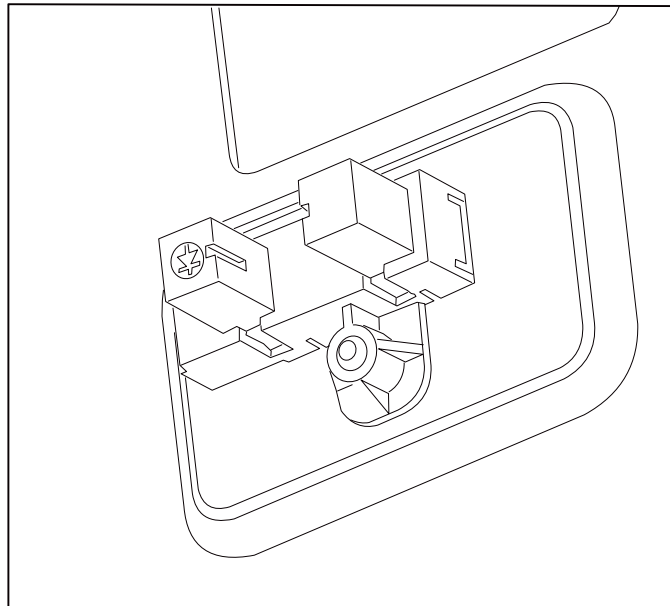
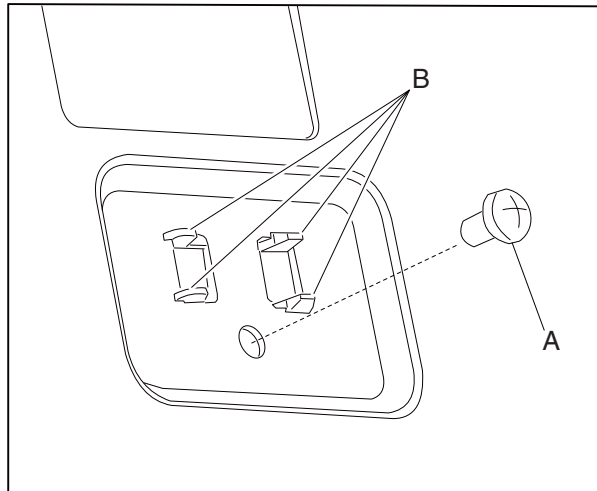

5. Remove the sensor (HCIT tray raised HP).



## Sensor (HCIT pass through) with cable removal

**Note:** Carefully remove the base machine from the HCIT tray assembly before proceeding.

1. Remove the HCIT cover, left. Go to **“High capacity input tray (HCIT) cover, left removal”** on page 4-122.
2. Disconnect the sensor (HCIT pass through) cable connector from the HCIT controller card assembly.

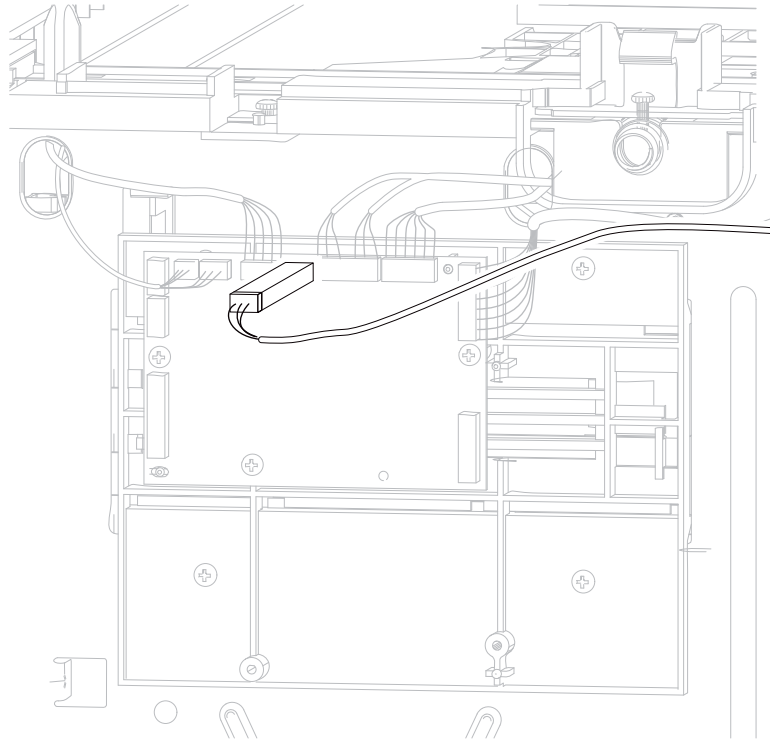

**Note:** Remove the cable restraint, and observe the routing for reinstallation.

3. Release the hooks (A) securing the sensor (HCIT pass through) to the machine.
4. Remove the sensor (HCIT pass through) with cable from the top plate.

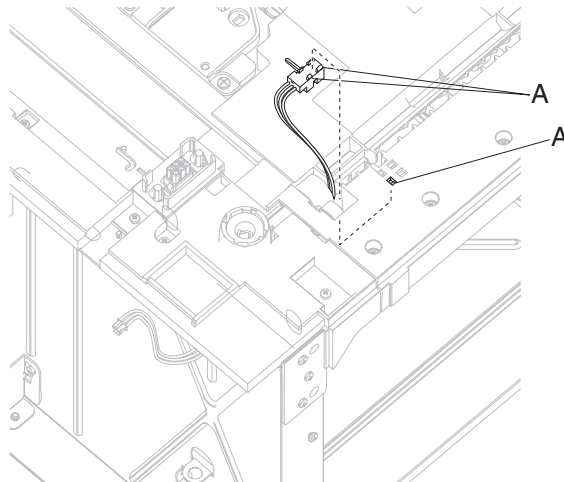

## Sensor (pass through) with cable removal

1. Remove the 250-sheet frame assembly. Go to **“250-sheet frame assembly removal” on page 4-104.**
2. Disconnect the sensor (pass through) cable connector from the 250-sheet controller card.
3. Remove the sensor (pass through) with cable.

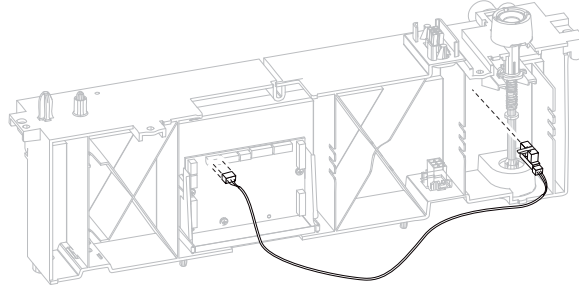

## Sensor (pass through) with cable removal

1. Remove the 550-sheet frame assembly. Go to **“550-sheet frame assembly removal” on page 4-109.**
2. Disconnect the sensor (pass through) cable connector from the 550-sheet controller card.

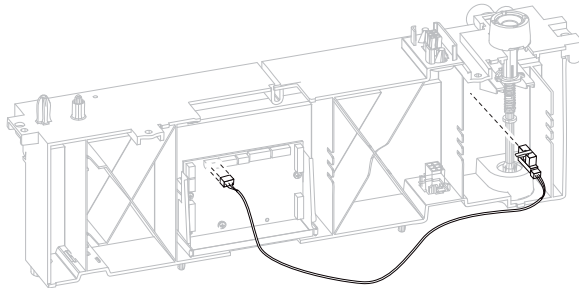

3. Remove the sensor (pass through) with cable.

## Tray roller catch assembly removal

1. Remove the media tray catch spring. Go to **“Media tray catch spring removal” on page 4-158.**

2. Remove the tray roller catch assembly from the drawer.

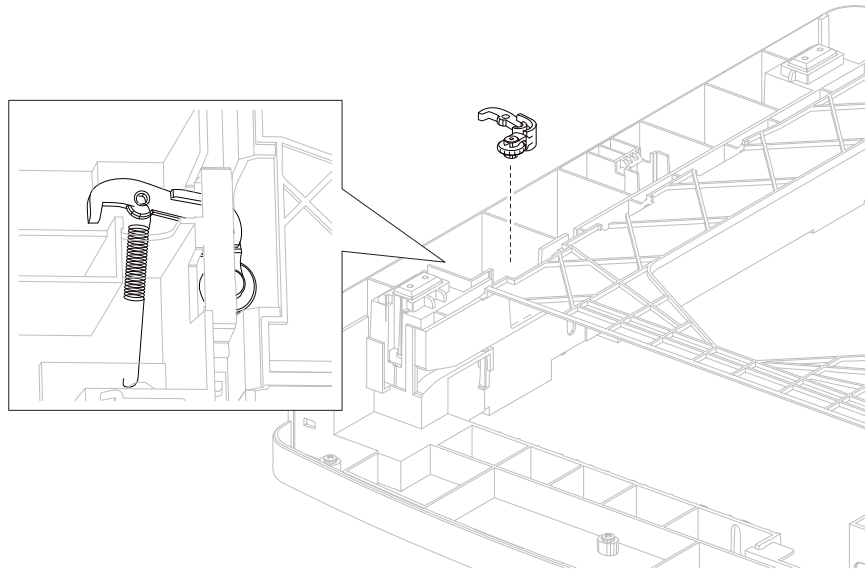

### Tray roller catch assembly removal

1. Remove the media tray catch spring. Go to **“Media tray catch spring removal”** on page 4-158.
2. Remove the tray roller catch assembly from the drawer.

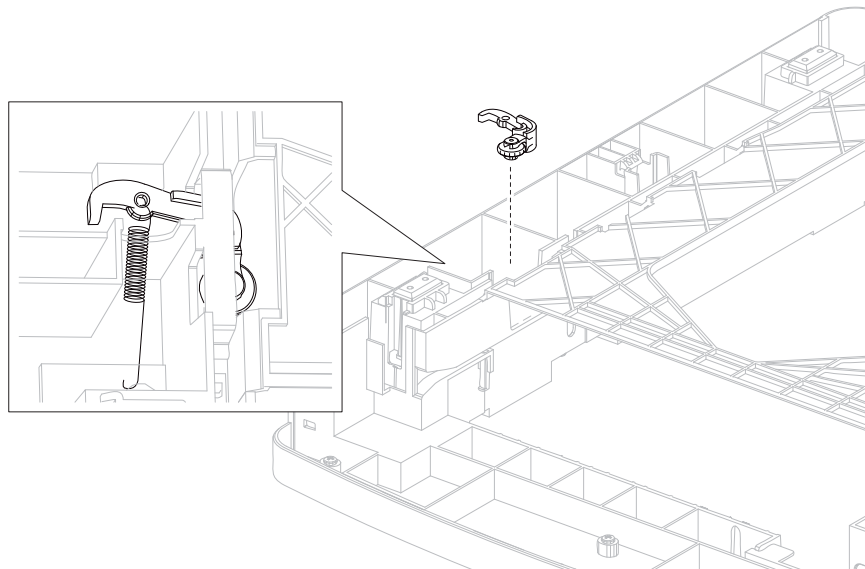

### Upper interface cable assembly removal

1. Remove the 550-sheet frame assembly. Go to **“Media size actuator removal”** on page 4-159.
2. Disconnect the upper interface cable connector (A) from the 550-sheet controller card.

3. Release the two hooks (B) securing the options auto connect to the 550-sheet frame.

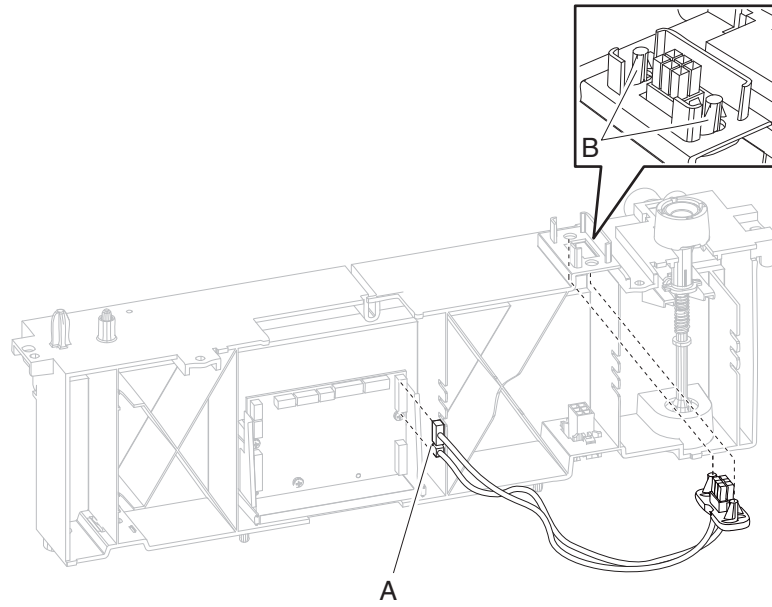

4. Remove the upper interface cable assembly.

## 5. Connector locations and connections

---

### Connections

A wiring diagram showing connector locations will be inserted here at a later date.



## 6. Preventive maintenance

This chapter describes procedures for printer preventive maintenance. Following these recommendations can help prevent problems and maintain optimum performance.

---

### Safety inspection guide

The purpose of this inspection guide is to aid you in identifying unsafe conditions.

If any unsafe conditions exist, find out how serious the hazard could be and if you can continue before you correct the hazard.

Check the following items:

- Damaged, missing, or altered parts, especially in the area of the on/off switch and the power supply.
- Damaged, missing, or altered covers, especially in the area of the top cover and the power supply cover.
- Possible safety exposure from any non-Lexmark attachments.

---

### Lubrication specifications

No requirements for this printer.

---

### Individual maintenance part expected life

Description	Part number	Expected part life
Charge roll assembly with tool	40X5852	300K
Transfer roll assembly with tool	40X1886	300K
Pick roll assembly (2)	40X4308	300K
Printer maintenance kit (100 V type 1 fuser)	40X4723	300K
Printer maintenance kit (110 V type 1 fuser)	40X4724	300K
Printer maintenance kit (220 V type 1 fuser)	40X4765	300K
Printer maintenance kit (100 V type 2 fuser)	40X4766	150K
Printer maintenance kit (110 V type 2 fuser)	40X4767	150K
Printer maintenance kit (220 V type 2 fuser)	40X4768	150K

---

## Scheduled maintenance

### Maintenance kit

The operator panel displays the message 80 Scheduled Maintenance at required maintenance intervals. It is necessary to replace the fuser assembly, transfer roller, charge roll, and pick tires at this interval to maintain the print quality and reliability of the printer. The parts are available as a maintenance kit with the following part numbers:

Description	Part number	Maintenance Interval
Printer maintenance kit (100V)	40X4723	300K
Printer maintenance kit (110V)	40X4724	300K
Printer maintenance kit (220V)	40X4765	300K
Printer maintenance kit (100V type 2 fuser)	40X4766	150K
Printer maintenance kit (110V type 2 fuser)	40X4767	150K
Printer maintenance kit (220V type 2 fuser)	40X4768	150K

After replacing the kit, the maintenance count must be reset to zero to clear the "80 Scheduled Maintenance" message. See **"Maintenance page counter reset (Reset Cnt)" on page 3-26**.



## 7. Parts catalog

### How to use this parts catalog

The following legend is used in the parts catalog:

Asm-Index	Part number	Units/mach - OR - Units/option	Units/ kit or pkg	Description
-----------	-------------	--------------------------------------	-------------------------	-------------

- **Asm-index:** identifies the assembly and the item in the diagram. For example, 3-1 indicates Assembly 3 and the item number 1.
- **Part number:** identifies the unique number that identifies this FRU.
- **Units/mach:** refers to the number of units actually used in the base machine or product.
- **Units/option:** refers to the number of units used in the option and does not include the base machine.
- **Units/kit or Pkg:** refers to the number of units packaged together and identified by the part number.
- **NS:** (Not shown) in the Asm-Index column indicates that the part is procurable but is not pictured in the illustration.
- **PP:** (Parts Packet) in the parts description column indicates the part is contained in a parts packet.

Model information used in the parts catalog.

Machine type	Model	Configuration
4062-01A	T650n	Network
4062-21A	T652n	Network
4062-23A	T652dn	Network
4062-41A	T654n	Network
4062-43A	T654dn	Network
4062-630	T656dne	Network

# Assembly 1: Covers

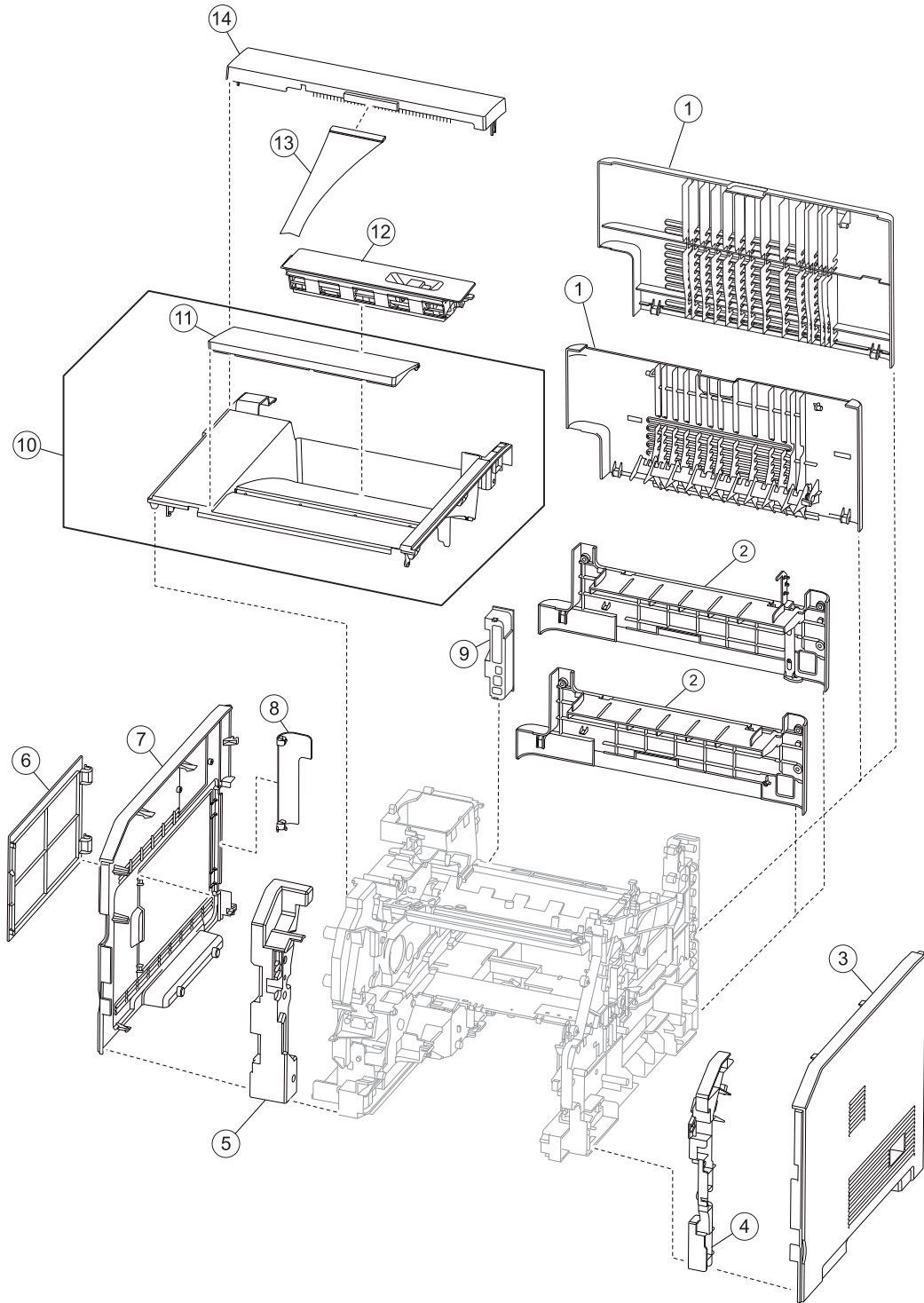

## Assembly 1: Covers

Asm-Index	Part number	Units/mach	Units/kit or pkg	Description
1	40X4332	1	1	Door assembly, rear (T650)
1	40X4329	1	1	Door assembly, rear (T652)
1	40X4331	1	1	Door assembly, rear (T654 and T656)
2	40X4334	1	1	Cover assembly, rear lower (T650)
2	40X4335	1	1	Cover assembly, rear lower (T652, T654, and T656)
3	40X4338	1	1	Side cover, right (T650)
3	40X1862	1	1	Side cover, right (T652)
3	40X4337	1	1	Side cover, right (T654)
3	40X7033	1	1	Side cover, right (T656)
4	40X4336	1	1	Inner cover, right (T650, T652, and T654)
5	40X4322	1	1	Inner cover, left (T650, T652, and T654)
6	40X4339	1	1	Access door (T650, T652, and T654)
6	40X7034	1	1	Access cover (T656)
7	40X4324	1	1	Side cover, left (T650)
7	40X4325	1	1	Side cover, left (T652)
7	40X4323	1	1	Side cover, left (T654)
7	40X7032	1	1	Side cover, left (T656)
8	40X4330	1	1	Connection access cover, rear (T650)
8	40X4314	1	1	Connection access cover, rear (T652, T654, and T656)
9	40X4630	1	1	Connection bezel assembly, rear (T650)
9	40X4629	1	1	Connection bezel assembly, rear (T652, T654, and T656)
10	40X4320	1	1	Laser cover assembly, 250 sheet output (T650 and T652)
10	40X4321	1	1	Laser cover assembly, 500 sheet output (T654)
10	40X7031	1	1	Laser cover assembly, 500 sheet output (T656)
11	40X4311	1	1	Media support (T650, T652)
11	40X4697	1	1	Media support (T654)
11	40X1973	1	1	Media support (T656)
12	40X4417	1	1	Fuser wiper cover assembly
13	40X4470	1	2	Output bail
14	40X4326	1	1	Output cover assembly

## Assembly 2: T650, T652, and T654 Operator panel

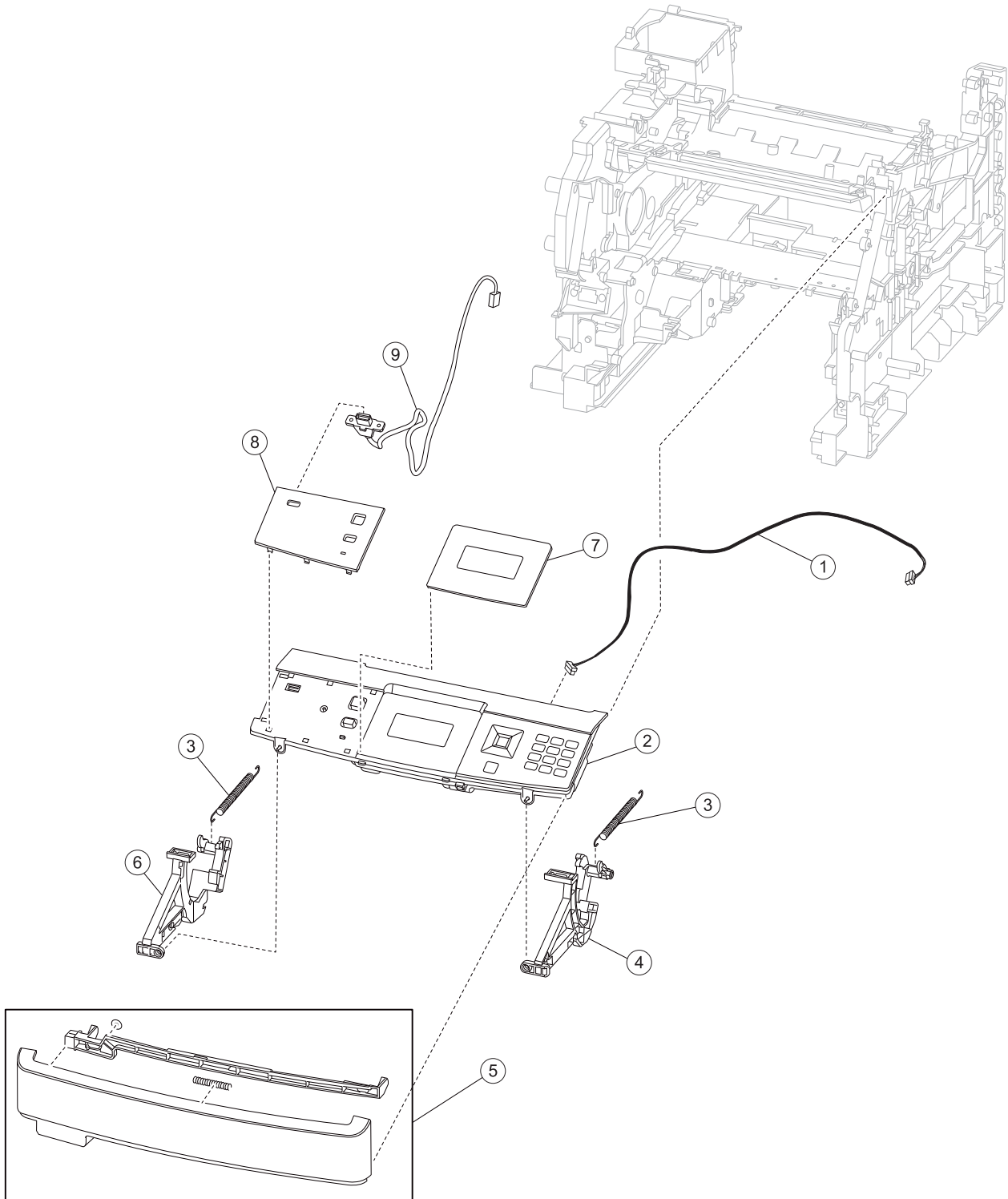

## Assembly 2: T650, T652, and T654 Operator panel

Asm-Index	Part number	Units/mach	Units/kit or pkg	Description
1	40X4366	1	1	Operator panel cable assembly (T650, T652, and T654)
2	40X4462	1	1	Operator panel door assembly (T650, T652, and T654)
3	40X4380	2	1	Counterbalance spring (T650, T652, and T654)
4	40X4397	1	1	Operator panel hinge assembly, right (T650, T652, and T654)
5	40X4616	1	1	Operator panel latch assembly (T650, T652, and T654)
6	40X4396	1	1	Operator panel hinge assembly, left (T650, T652, and T654)
7	40X4415	1	1	LCD screen bezel (T650n)
7	40X4494	1	1	LCD screen bezel (T652n)
7	40X4471	1	1	LCD screen bezel (T652dn)
7	40X4628	1	1	LCD screen bezel (T654n)
7	40X4627	1	1	LCD screen bezel (T654dn)
8	40X5746	1	1	Operator panel bezel, left
8	40X5729	1	1	Operator panel bezel, left (NON USB)
9	40X4377	1	1	USB cable assembly (T650, T652, and T654)

**Warning:** When replacing any of the following components:

- Operator panel assembly
- System card assembly

Only replace one component at a time. Replace the required component and perform a POR before replacing a second component listed above. If this procedure is not followed, the printer will be rendered inoperable. Never replace two or more of the components listed above without a POR after installing each one or the printer will be rendered inoperable.

Never install and remove components listed above as a method of troubleshooting components. Once a component has been installed in a machine, it can not be used in another machine. It must be returned to the manufacturer.

### Assembly 3: T656dne Operator panel, MPF and smart card

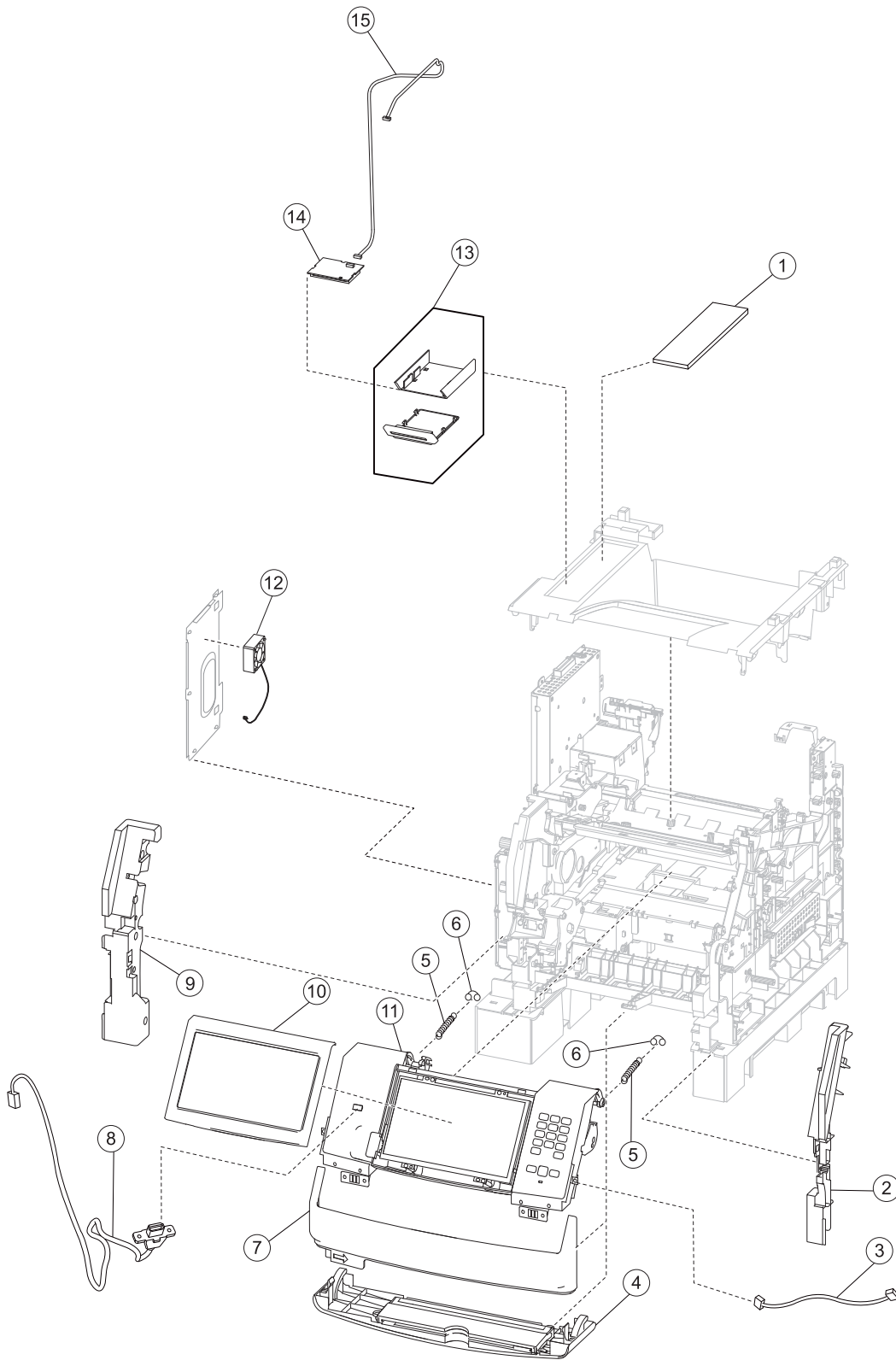

### Assembly 3: T656 Operator panel, MPF and smart card

Asm-Index	Part number	Units/mach	Units/kit or pkg	Description
1	40X7039	1	1	Card reader cable assembly (T656)
2	40X1972	1	1	Inner cover, right (T656)
3	40X2045	1	1	Operator panel cable assembly (T656)
4	40X2089	1	1	MPF tray door assembly (T656)
5	40X2077	2	1	Counterbalance spring (T656)
6	40X2078	2	1	Spring connector (T656)
7	40X4631	1	1	Operator panel door latch assembly (T656)
8	40X2051	1	1	USB cable assembly (T656)
9	40X1971	1	1	Inner cover, left (T656)
10	40X7038	1	1	Operator panel bezel (T656)
11	40X1385	1	1	Operator panel door assembly (T656)
12	40X7035	1	1	Hard drive cooling fan (T656)
13	40X7042	1	1	Card reader mounting bracket (T656)
14	40X4602	1	1	Card reader assembly (3121 contact) (T656)
14	40X4603	1	1	Card reader assembly (5121 contact/RFID) (T656)
14	40X4604	1	1	Card reader assembly (5125 contact/HID) (T656)
15	40X7037	1	1	Card reader cable assembly (T656)

### Assembly 4: Drive motor assemblies and duplex

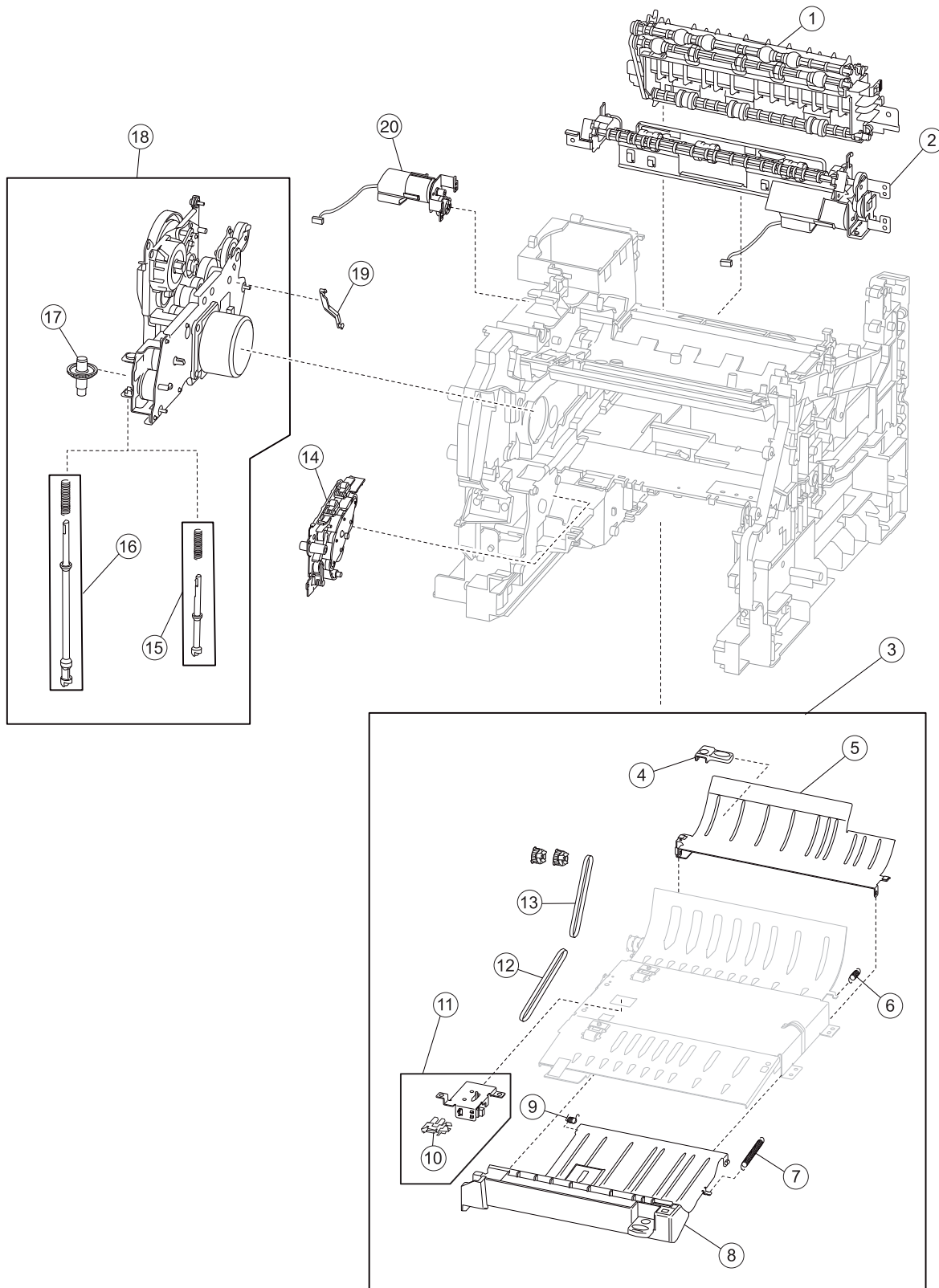



## Assembly 4: Drive motor assemblies and duplex

Asm-Index	Part number	Units/mach	Units/kit or pkg	Description
1	40X4465	1	1	Redrive assembly (T650)
1	40X4466	1	1	Redrive assembly (T652)
1	40X4467	1	1	Redrive assembly (T654 and T656)
2	40X4344	1	1	Duplex drive motor assembly (T652, T654, and T656)
3	40X4346	1	5	Duplex assembly with 2 belts and 2 pulleys (T652, T654, and T656)
4	40X4351	1	1	Duplex guide handle (T652, T654, and T656)
5	40X4352	1	1	Duplex guide, rear (T652, T654, and T656)
6	40X4353	1	1	Duplex guide spring, rear (T652, T654, and T656)
7	40X4349	1	1	Duplex guide spring, right (T652, T654, and T656)
8	40X4348	1	1	Duplex guide assembly, front (T652, T654, and T656)
9	40X5551	1	1	Duplex guide spring, left (T652, T654, and T656)
10	40X4369	1	1	Sensor (duplex input) (T652, T654, and T656)
11	40X4345	1	1	Duplex (input) sensor assembly (T652, T654, and T656)
12	40X4350	1	1	Duplex drive belt, lower (T652, T654, and T656)
13	40X4354	1	1	Duplex drive belt, upper (T652, T654, and T656)
14	40X4302	1	3	Aligner assembly with ground strap and adj. screw (T650)
14	40X4303	1	3	Aligner assembly with ground strap and adj. screw (T652, T654, and T656)
15	40X1863	1	2	Option drive shaft with spring (T650)
16	40X4473	1	2	Option drive shaft with spring (T652, T654, and T656)
17	99A0954	1	1	Bevel gear with grease packet and washer <ul style="list-style-type: none"> <li>• Bevel gear (1)</li> <li>• Instruction sheet (1)</li> <li>• Grease packet (1)</li> </ul>
18	40X5749	1	1	Main drive motor assembly with option drive shaft
19	40X4386	1	1	Fuser drive release linkage
20	40X4343	1	1	Redrive motor assembly (T652, T654, and T656)

### Assembly 5: Media path and ducts

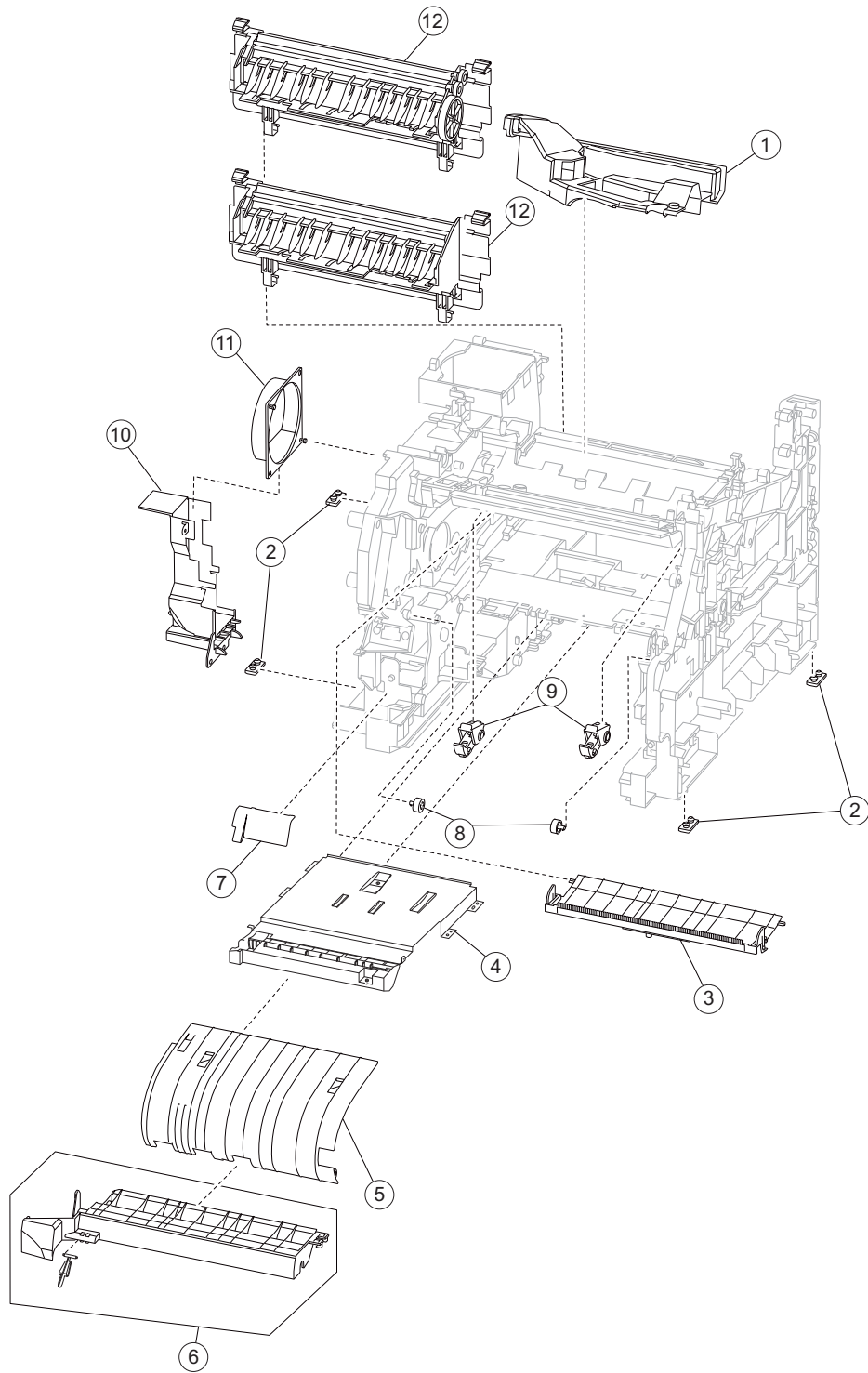

## Assembly 5: Media path and ducts

Asm-Index	Part number	Units/mach	Units/kit or pkg	Description
1	40X4384	1	1	EP cooling fan duct
2	40X4390	4	1	Machine pad
3	40X1869	1	1	Transfer deflector with static brush
4	40X1889	1	1	Duplex deletion assembly (T652, T654)
5	40X4387	1	1	Inner deflector (T650)
5	40X4388	1	1	Inner deflector (T652, T654, and T656)
6	40X1900	1	1	Media turn guide with actuator
7	40X4385	1	1	Envelope feeder interface cover
8	40X4406	2	1	Print cartridge support roller
9	40X1868	2	1	Print cartridge clamp assembly
10	40X4389	1	1	LVPS cooling duct
11	40X4391	1	1	Main cooling duct (T650)
11	40X4392	1	1	Main cooling duct (T652, T654, and T656)
12	40X4319	1	1	Fuser access door assembly (T650)
12	40X4318	1	1	Fuser access door assembly (T652, T654, and T656)

### Assembly 6: Printhead, charge, and transfer

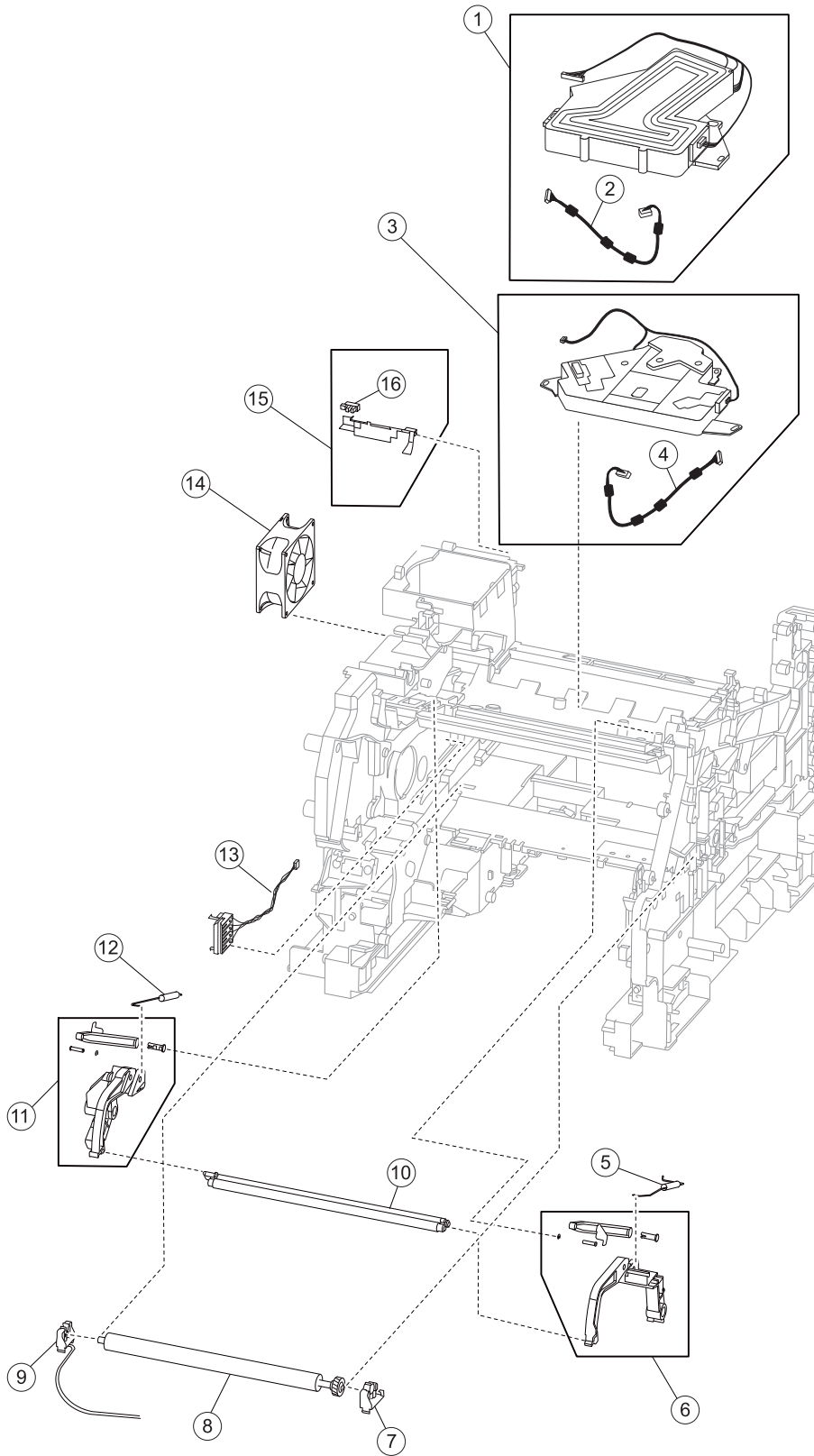

## Assembly 6: Printhead, charge, and transfer

Asm-Index	Part number	Units/mach	Units/kit or pkg	Description
1	40X4464	1	2	Printhead with cable assembly (T652 and T654)
1	40X7040	1	1	Printhead with cable assembly (T656)
2	40X1865	1	1	Printhead cable (T652, T654, and T656)
3	40X4463	1	2	Printhead with cable assembly (T650)
4	40X4367	1	1	Printhead cable assembly (T650)
5	40X4317	1	1	Charge roll link spring, right
6	40X1893	1	4	Charge roll arm assembly with cable, right
7	40X1888	1	2	Transfer roll bracket assembly, right
8	40X1886	1	1	Transfer roll assembly with tool
9	40X1887	1	2	Transfer roll bracket with cable assembly, left
10	40X5852	1	1	Charge roll assembly with tool
11	40X1892	1	4	Charge roll arm assembly, left
12	40X4316	1	1	Charge roll link spring, left
13	40X1864	1	1	Print cartridge ID connector assembly
14	40X4363	1	1	Main cooling fan (T650)
14	40X4364	1	1	Main cooling fan (T652, T654, and T656)
15	40X4372	1	1	Sensor (standard bin exit) actuator assembly
16	40X4369	1	1	Sensor (standard bin exit)

### Assembly 7: Pick arm assembly, trays, and MPF

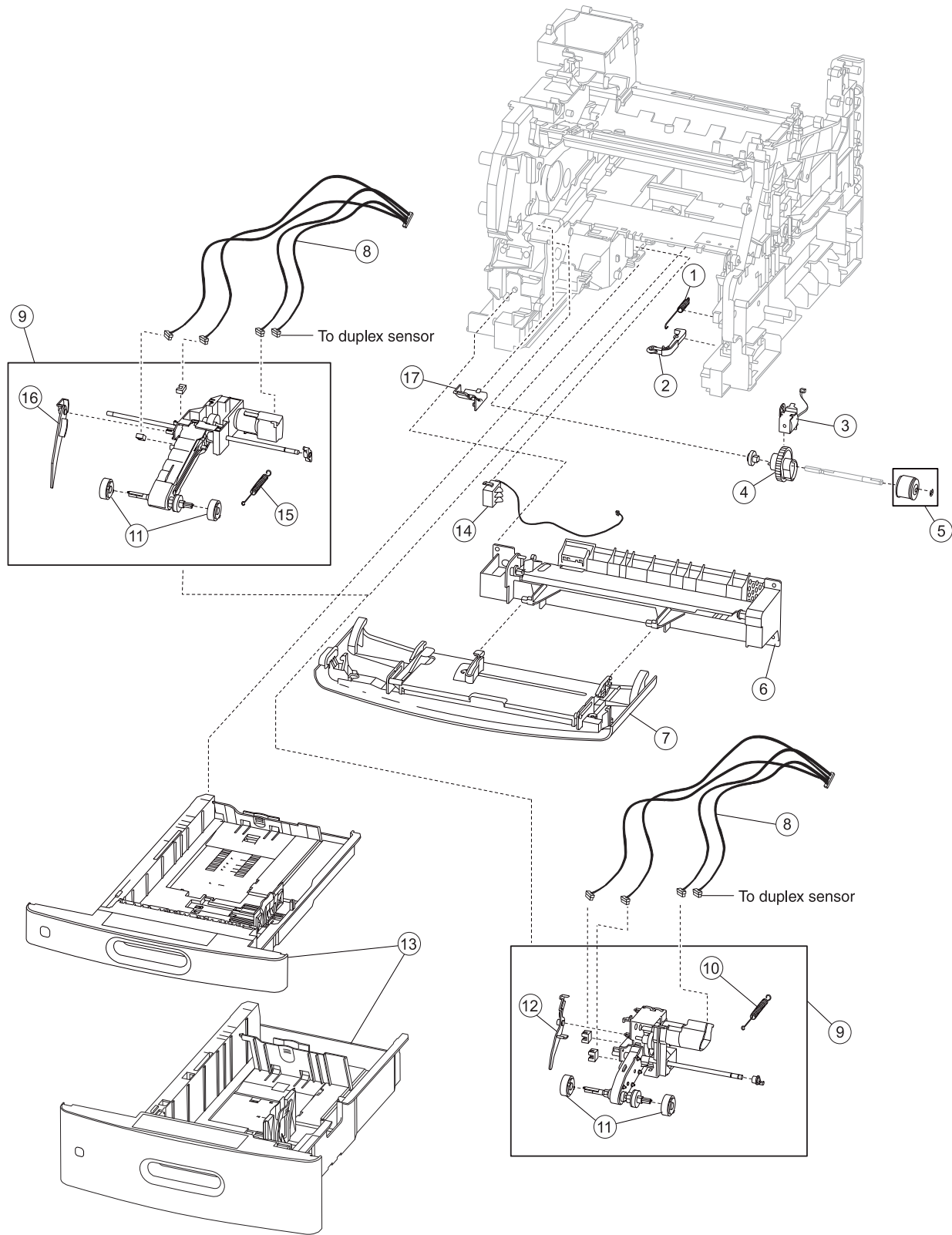

## Assembly 7: Pick arm assembly, trays, and MPF

Asm-Index	Part number	Units/mach	Units/kit or pkg	Description
1	40X4394	1	1	Tray catch spring
2	40X4395	1	1	Tray roller catch assembly
3	40X4365	1	1	MPF pick solenoid assembly
4	40X4457	1	1	MPF cam gear
5	40X1883	4	1	MPF pick roll assembly with flanges and clip
6	40X4458	1	1	MPF lift plate assembly (T650)
6	40X4459	1	1	MPF lift plate assembly (T652, T654, and T656)
7	40X4460	1	1	MPF tray door assembly (T650)
7	40X4461	1	1	MPF tray door assembly (T652)
7	40X1884	1	1	MPF tray door assembly (T654)
8	40X4313	1	1	Pick arm sensor cable assembly
9	40X4304	1	1	Pick arm assembly with spring, 250 sheet (T650)
9	40X4305	1	1	Pick arm assembly with spring, 500 sheet (T652, T654, and T656)
10	40X4306	1	1	Pick arm spring (T650)
11	40X4308	1	2	Pick roll assembly (2)
12	40X4309	1	1	250 Sheet media out actuator (T650)
13	40X4468	1	1	Media tray assembly, 250 sheet
13	40X4469	1	1	Media tray assembly, 550 sheet
14	40X4472	1	1	Switch (media size) assembly
15	40X4307	1	1	Pick arm spring (T652, T654, and T656)
16	40X4310	1	1	550 Sheet media out actuator (T652, T654, and T656)
17	40X1876	1	1	MPF gear shield

## Assembly 8: LVPS, fuser and electrical cables 1

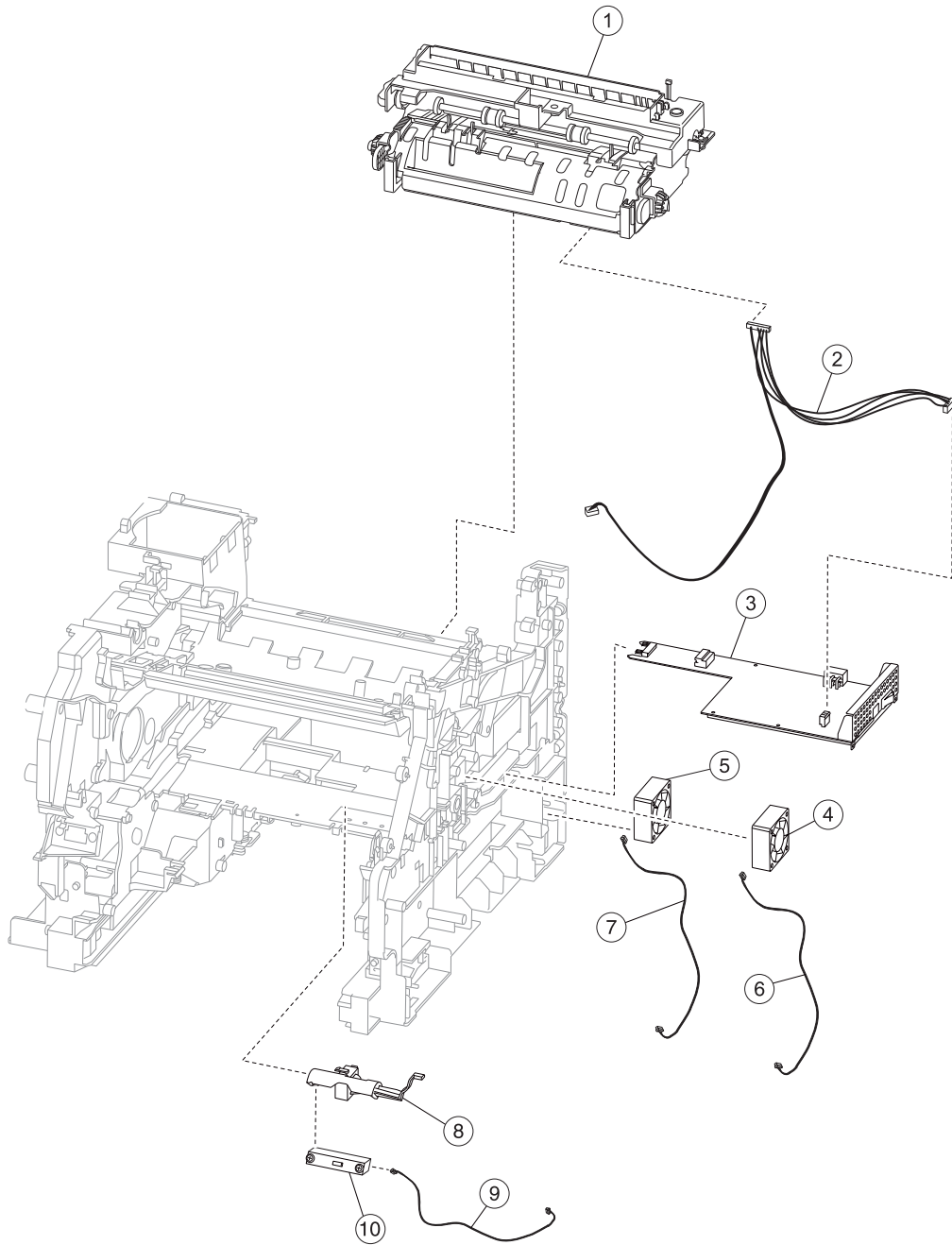



**Assembly 8: LVPS, fuser and electrical cables 1**

<b>Asm-Index</b>	<b>Part number</b>	<b>Units/mach</b>	<b>Units/kit or pkg</b>	<b>Description</b>
1	40X1870	1	1	100V type 1 fuser assembly
1	40X4418	1	1	110V type 1 fuser assembly
1	40X1871	1	1	220V type 1 fuser assembly
1	40X5853	1	1	100V type 2 fuser assembly
1	40X5854	1	1	110V type 2 fuser assembly
1	40X5855	1	1	220V type 2 fuser assembly
2	40X4419	1	1	Fuser interface cable assembly
3	40X4355	1	1	LVPS card assembly
4	40X4359	1	1	Print cartridge cooling fan
5	40X4356	1	1	Duplex cooling fan
6	40X4360	1	1	Print cartridge cooling fan cable assembly
7	40X4357	1	1	Duplex cooling fan cable assembly
8	40X1866	1	1	Sensor shield assembly
9	40X4379	1	1	Toner density sensor cable assembly
10	40X4378	1	1	Sensor (toner density)

## Assembly 9: HVPS, system card, and electrical cables 2

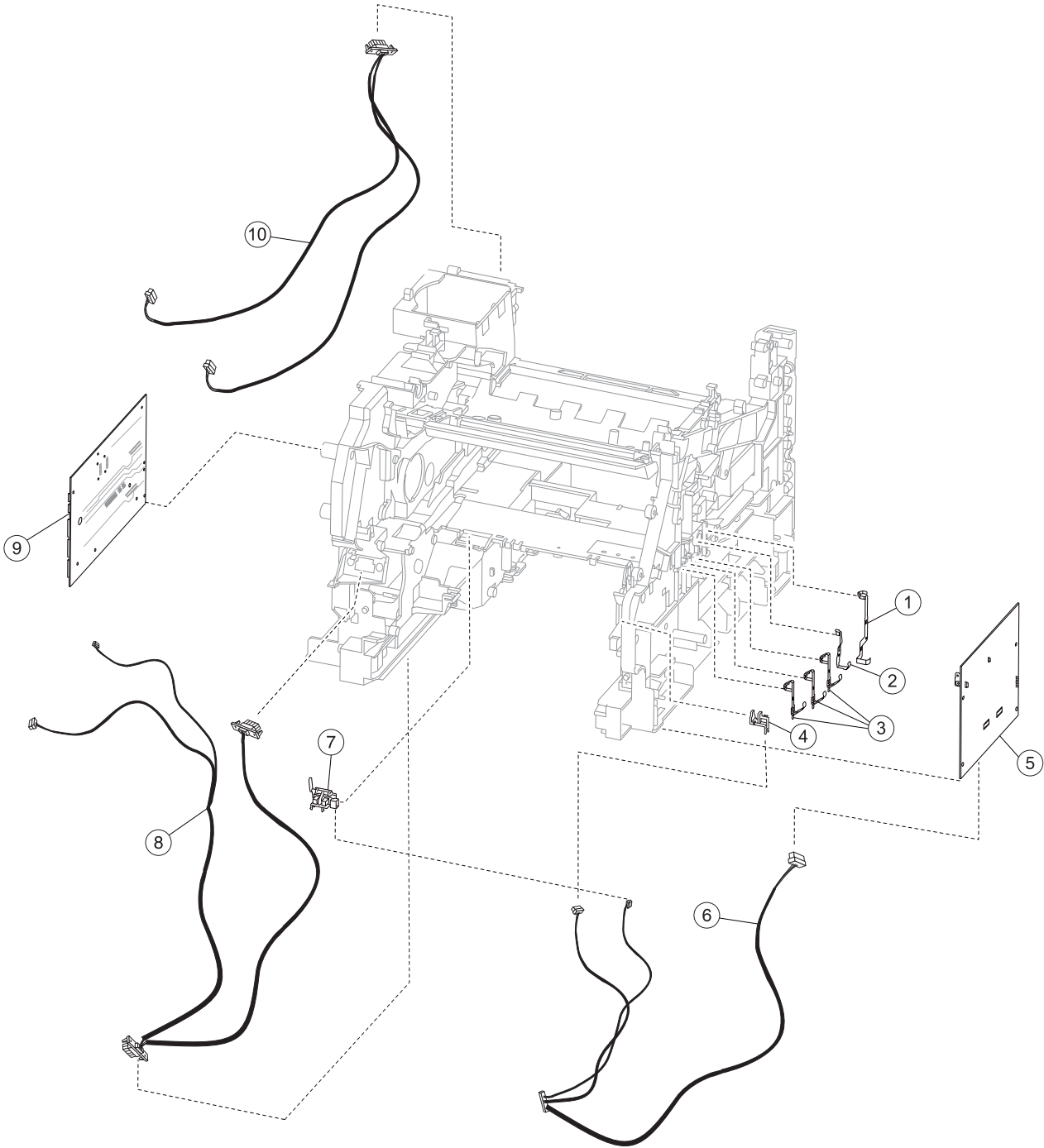

## Assembly 9: HVPS, system card, and electrical cables 2

Asm-Index	Part number	Units/mach	Units/kit or pkg	Description
1	40X4383	1	1	Cleaning blade contact
2	40X4381	1	1	Drum grounding contact
3	40X4382	1	1	Print cartridge HV contact
4	40X4370	1	1	Sensor (toner empty)
5	40X4362	1	1	HVPS card assembly
6	40X4361	1	1	HVPS / sensor cable assembly
7	40X4368	1	1	Sensor (input)
8	40X4358	1	1	Envelope / input option tray cable assembly
9	40X5911	1	1	System card assembly (T654)
9	40X7036	1	1	System card assembly (T656)
9	40X4375	1	1	System card assembly (T650)
9	40X4474	1	1	System card assembly (T652)
10	40X4376	1	1	Output option interface cable assembly

**Warning:** When replacing any of the following components:

- Operator panel assembly
- System card assembly

Only replace one component at a time. Replace the required component and perform a POR before replacing a second component listed above. If this procedure is not followed, the printer will be rendered inoperable. Never replace two or more of the components listed above without a POR after installing each one or the printer will be rendered inoperable.

Never install and remove components listed above as a method of troubleshooting components. Once a component has been installed in a machine, it can not be used in another machine. It must be returned to the manufacturer.

### Assembly 10: 250 Sheet option tray assembly

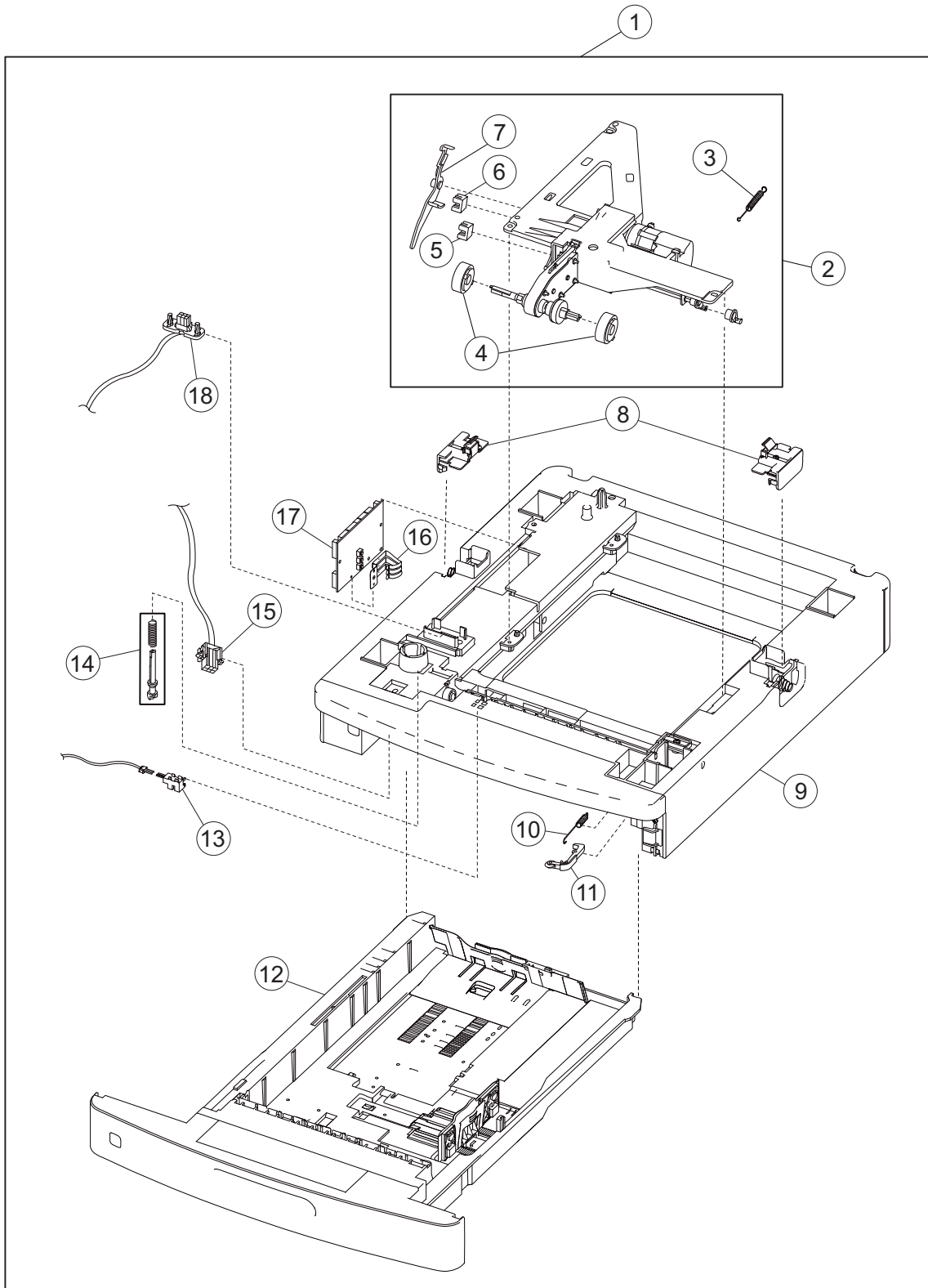

## Assembly 10: 250 Sheet option tray assembly

Asm-Index	Part number	Units/mach	Units/kit or pkg	Description
1	40X4569	1	1	Complete 250 sheet option tray assembly
2	40X3447	1	1	250 Sheet pick arm bracket assembly
3	40X3448	1	1	250 Sheet bellcrank recoil spring
4	40X4308	2	1	Pick roll assembly (2)
5	40X4369	1	1	Sensor (media low)
6	40X4369	1	1	Sensor (media empty)
7	40X4309	1	1	250 Sheet media out actuator
8	40X4570	1	1	Anti-tip latch assembly
9	40X3453	1	1	250 Sheet option drawer assembly
10	40X3822	1	1	Media tray catch spring
11	40X4395	1	1	Media tray roller catch assembly
12	40X3449	1	1	Media tray assembly, 250 sheet
13	40X4575	1	1	Sensor (pass through) with cable
14	40X1863	1	1	250 Option drive shaft with spring
15	40X4572	1	1	Lower interface cable assembly
16	40X3854	1	1	Media size actuator
17	40X4574	1	1	250 Sheet controller card assembly
18	40X4571	1	1	Upper interface cable assembly

### Assembly 11: 550 Sheet option tray assembly

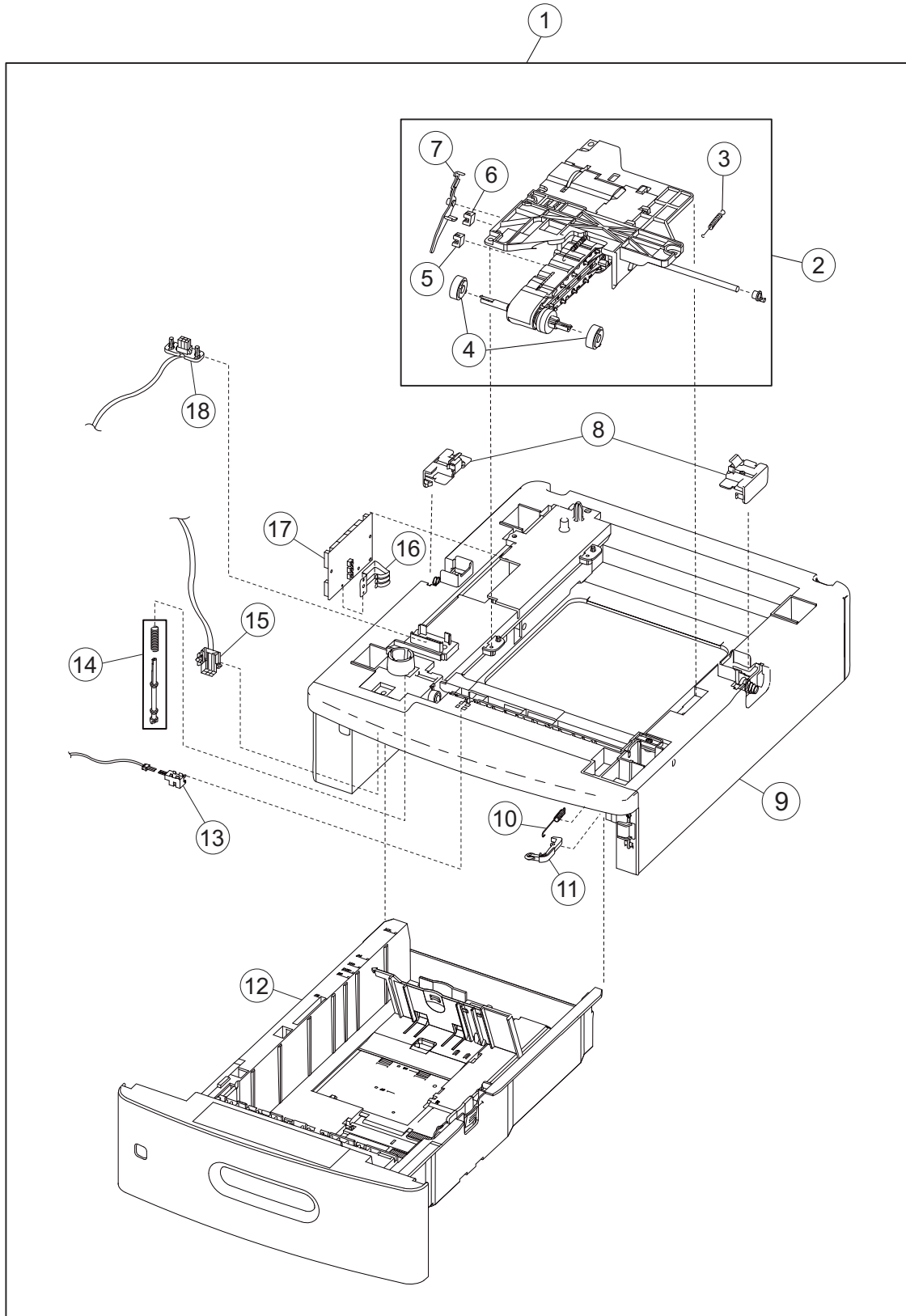

## Assembly 11: 550 Sheet option tray assembly

Asm-Index	Part number	Units/mach	Units/kit or pkg	Description
1	40X4576	1	1	Complete 550 sheet option tray assembly
2	40X3454	1	1	550 Sheet pick arm bracket assembly
3	40X4307	1	1	550 Sheet bellcrank recoil spring
4	40X4308	1	2	Pick roll assembly (2)
5	40X4369	1	1	Sensor (media low)
6	40X4369	1	1	Sensor (media empty)
7	40X4310	1	1	550 Sheet media out actuator
8	40X4570	2	2	Anti-tip latch assembly
9	40X3957	1	1	550 Sheet option drawer assembly
10	40X3822	1	1	Media tray catch spring
11	40X4395	1	1	Media tray roller catch assembly
12	40X4469	1	1	Media tray assembly, 550 sheet
13	40X4575	1	1	Sensor (pass through) with cable
14	40X4473	1	1	550 Option drive shaft with spring
15	40X4572	1	1	Lower interface cable assembly
16	40X3854	1	1	Media size actuator
17	40X4578	1	1	550 Sheet controller card assembly
18	40X4571	1	1	Upper interface cable assembly

### Assembly 12: HCIT Sheet option tray assembly

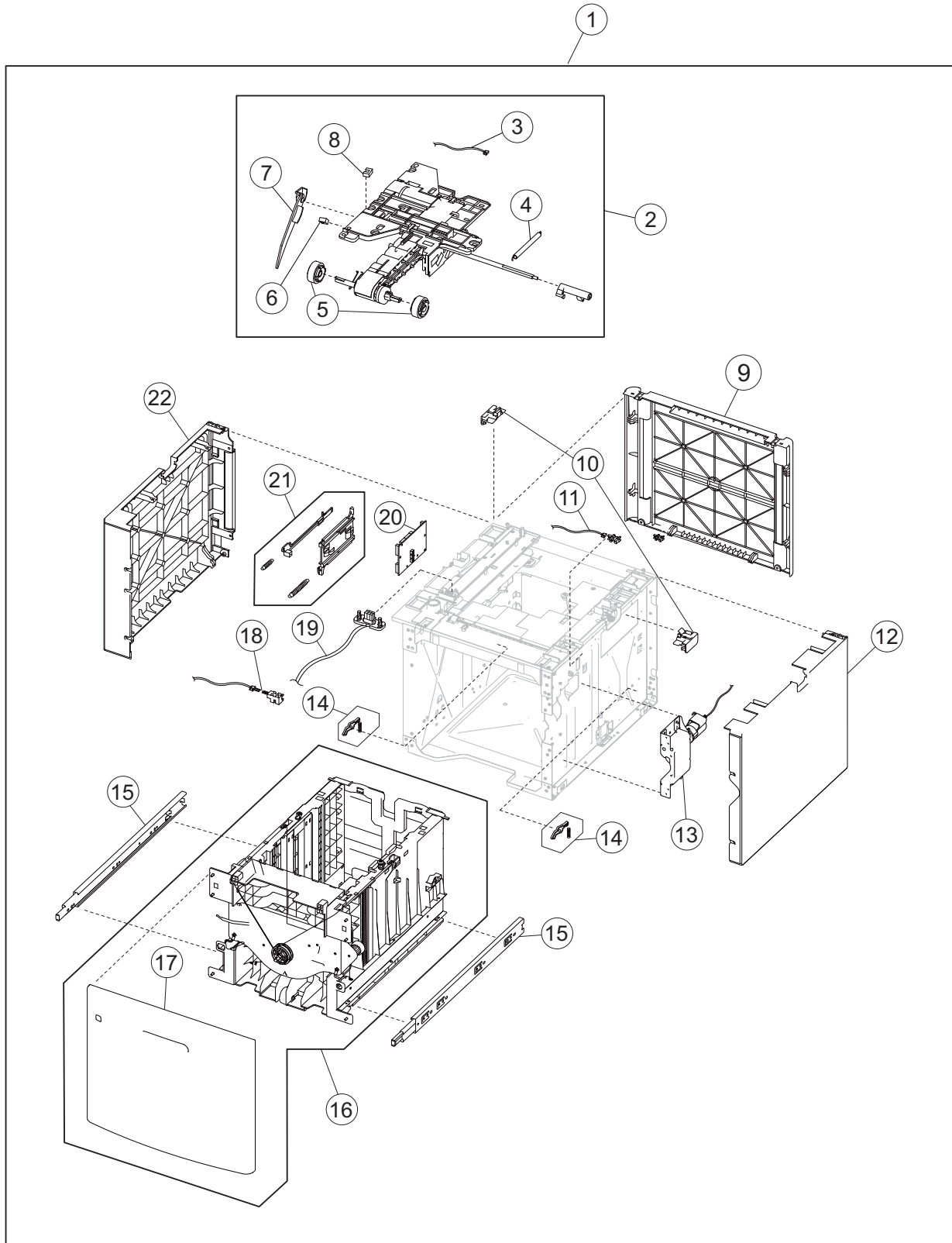



## Assembly 12: HCIT Sheet option tray assembly

Asm-Index	Part number	Units/mach	Units/kit or pkg	Description
1	40X4579	1	1	Complete HCIT option tray assembly
2	40X4590	1	2	HCIT pick arm bracket assembly
3	40X4595	1	1	Pick arm sensor cable assembly
4	40X4591	1	1	HCIT bellcrank recoil spring
5	40X4308	2	2	Pick roll assembly (2)
6	40X4369	2	1	Sensor (media low)
7	40X4310	1	1	550 Sheet media out actuator
8	40X4369	2	1	Sensor (media empty)
9	40X4581	1	1	HCIT cover, rear
10	40X4570	1	1	Anti-tip latch assembly
11	40X4588	1	1	Sensor (HCIT tray raised HP) with cable assembly
12	40X4582	1	1	HCIT cover, right
13	40X4586	1	1	HCIT tray lift drive motor assembly
14	40X4585	1	2	HCIT tray closed latch with spring
15	40X4593	2	2	HCIT drawer slide assembly
16	40X4580	1	1	HCIT media tray assembly
17	40X4584	1	1	HCIT tray cover, front
19	40X4594	1	1	HCIT interface cable assembly
18	40X4589	1	2	Sensor (HCIT pass through) with cable
20	40X4592	1	1	HCIT controller card assembly
21	40X4587	1	4	HCIT media size actuator assembly
22	40X4583	1	1	HCIT cover, left

### Assembly 13: SFP stapler assembly #1

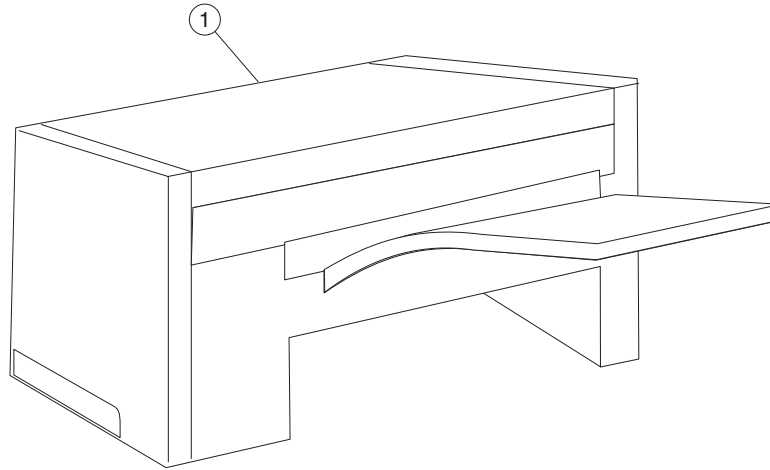

**Assembly 13: SFP stapler assembly # 1**

Asm-Index	Part number	Units/mach	Units/kit or pkg	Description
1	40X5547	1	1	SFP stapler assembly (comes completely assembled)

### Assembly 14: SFP stapler assembly #2

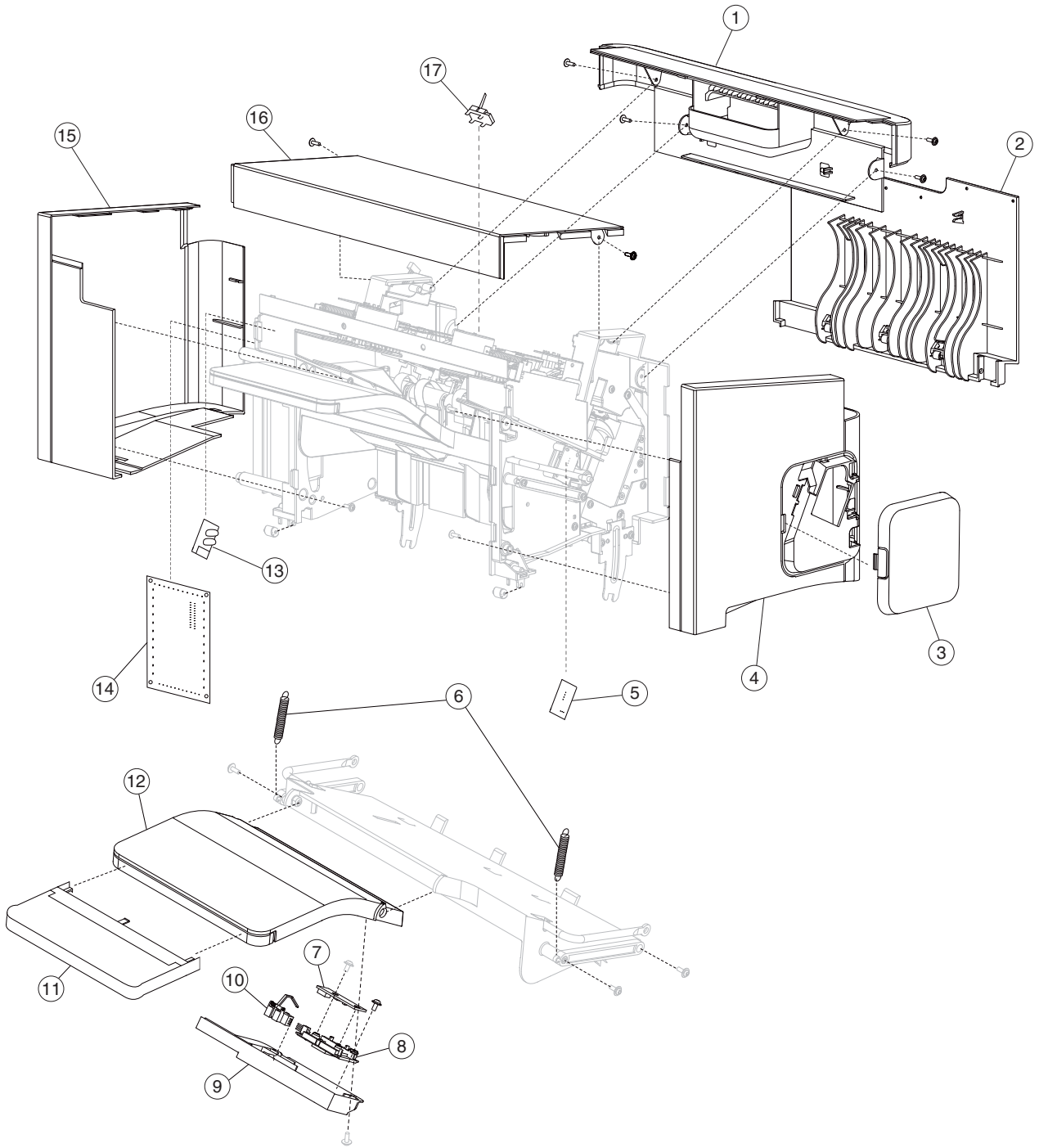

## Assembly 14: SFP stapler assembly #2

Asm-Index	Part number	Units/mach	Units/kit or pkg	Description
1	40X4612	1	1	Handle cover
2	40X4613	1	1	Rear door assembly
3	40X5910	1	1	Stapler cover
4	40X4610	1	1	Right cover
5	40X5544	1	1	Sensor (bin full receive)
6	40X4617	1	2	Finisher bin spring
7	40X5545	1	1	Standard output bin LED
8	40X5727	1	1	LED clear lens
9	40X5720	1	1	LED sensor cover
10	40X4618	1	1	Sensor (finisher bin media present)
11	40X4619	1	1	Media output bin extension
12	40X5541	1	1	Media output bin
13	40X4626	1	1	Sensor (bin full send)
14	40X4625	1	1	Stapler/stacker controller card assembly
15	40X4609	1	1	Left cover
16	40X4611	1	1	Top cover
17	40X5906	1	1	Sensor (stapler/stacker pass through)

### Assembly 15: SFP stapler assembly #3

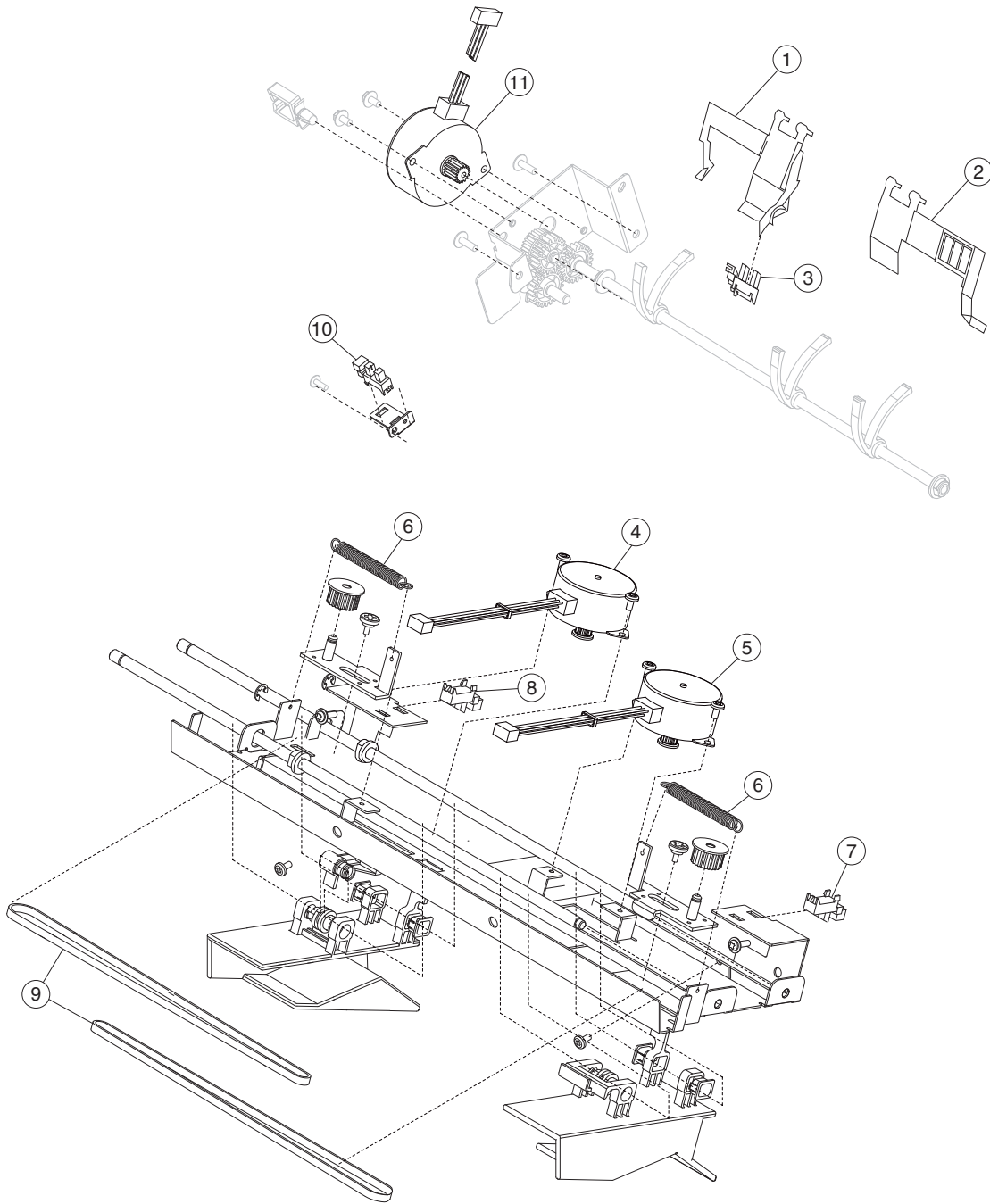

**Assembly 15: SFP stapler assembly #3**

<b>Asm-Index</b>	<b>Part number</b>	<b>Units/mach</b>	<b>Units/kit or pkg</b>	<b>Description</b>
1	40X4645	1	1	Media stack flap actuator
2	40X4646	1	1	Media stack flap
3	40X4369	1	1	Sensor (media stack)
4	40X4621	1	1	Left tamper motor assembly
5	40X4622	1	1	Right tamper motor assembly
6	40X4624	1	2	Tamper recoil spring
7	40X4369	1	1	Sensor (tamper HP right)
8	40X4369	1	1	Sensor (tamper HP left)
9	40X4623	1	1	Tamper drive belt
10	40X4369	1	1	Sensor (paddle HP)
11	40X4615	1	1	Paddle drive motor

## Assembly 16: SFP stapler assembly #4

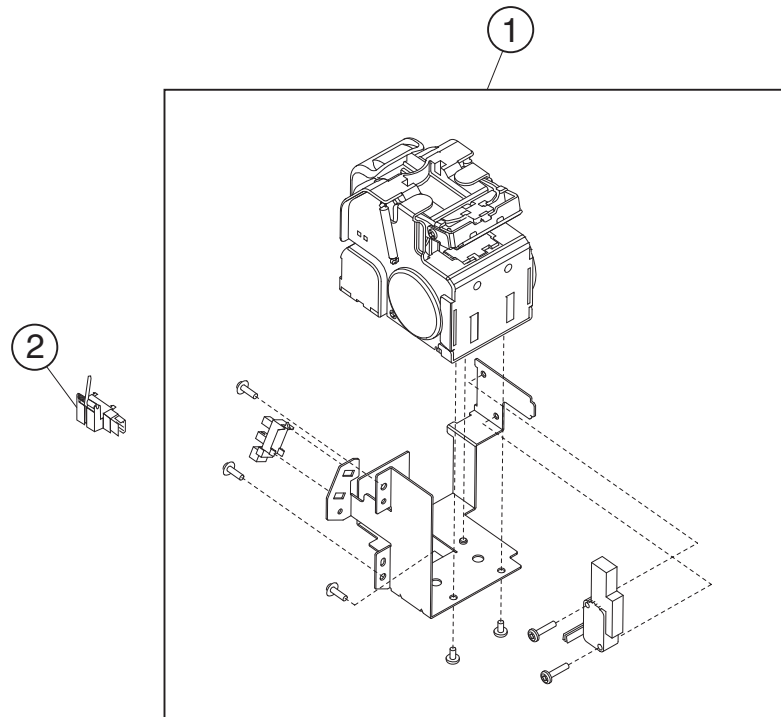



**Assembly 16: SFP stapler assembly #4**

<b>Asm-Index</b>	<b>Part number</b>	<b>Units/mach</b>	<b>Units/kit or pkg</b>	<b>Description</b>
1	40X4641	1	1	Stapler assembly
2	40X5909	1	1	Sensor (media in stapler)

### Assembly 17: 5-bin mailbox #1

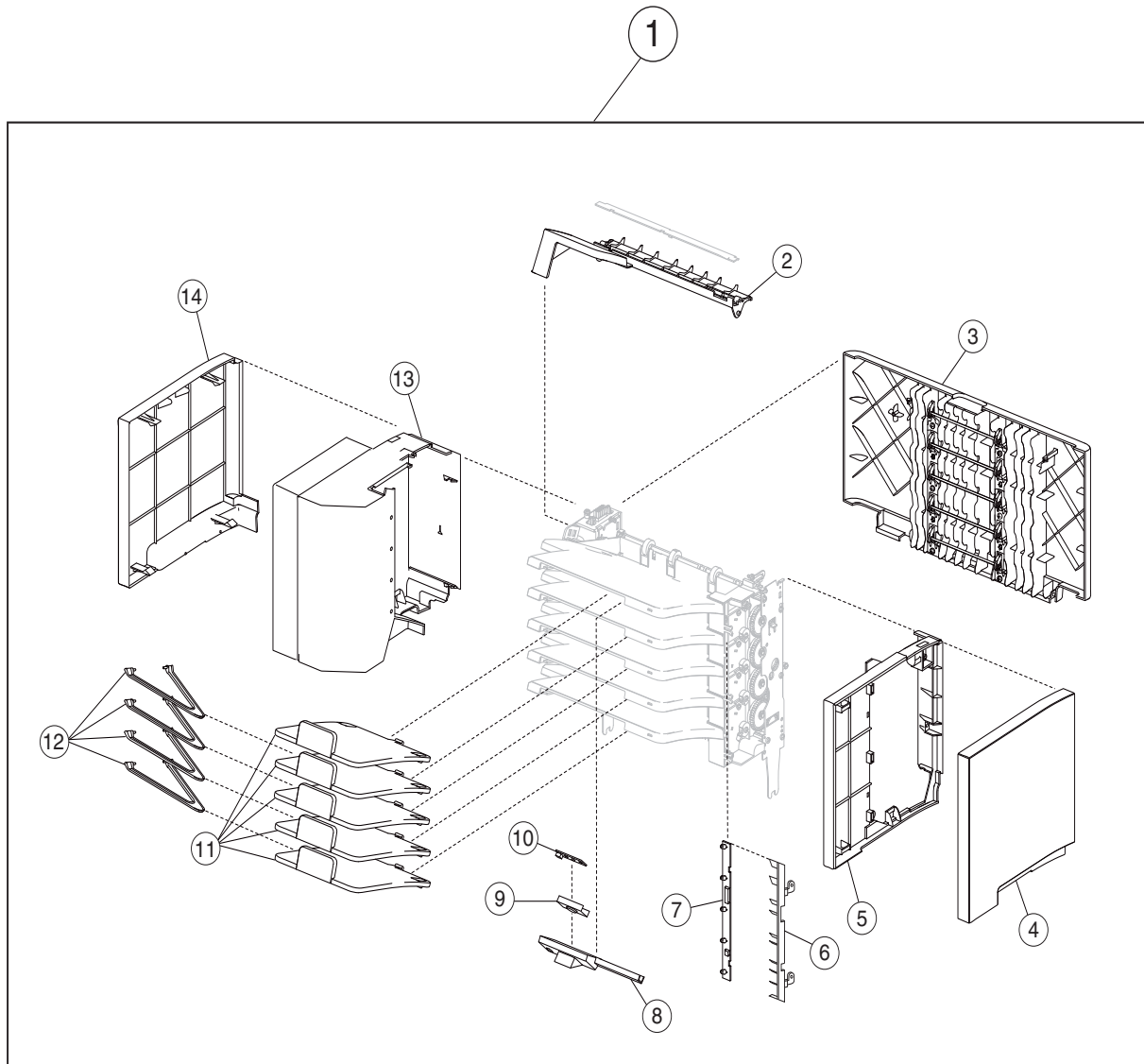

**Assembly 17: 5-bin mailbox #1**

<b>Asm-Index</b>	<b>Part number</b>	<b>Units/mach</b>	<b>Units/kit or pkg</b>	<b>Description</b>
1	40X5550	1	1	Complete 5 bin mailbox unit assembly
2	40X5708	1	1	Top cover
3	40X5709	1	1	Rear door assembly
4	40X5712	1	1	Right outer cover
5	40X5713	1	1	Right inner cover
6	40X5756	1	1	Output bin LED bracket
7	40X5717	1	1	Output bin LED assembly
8	40X5714	1	1	Standard output bin LED bracket
9	40X5755	1	1	LED clear lens
10	40X4773	1	1	Standard output bin LED
11	40X5753	1	1	Media bin extension assembly
12	56P4191	1	1	Media bail assembly
13	40X5711	1	1	Left inner cover
14	40X5710	1	1	Left outer cover

### Assembly 18: 5-bin mailbox #2io

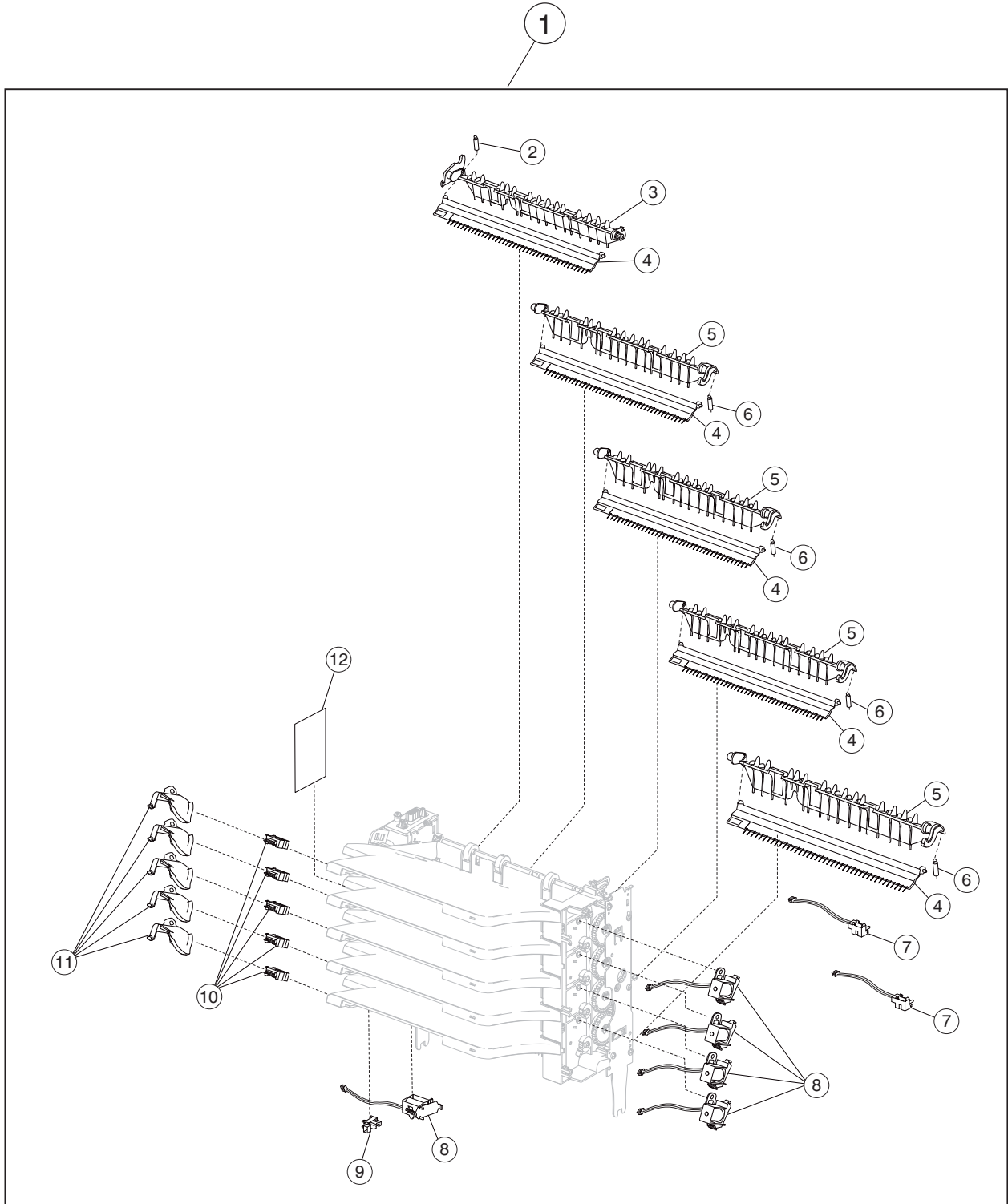

**Assembly 18: 5-bin mailbox #2**

<b>Asm-Index</b>	<b>Part number</b>	<b>Units/mach</b>	<b>Units/kit or pkg</b>	<b>Description</b>
1	40X5550	1	1	Complete 5 bin mailbox unit assembly
2	40X0028	1	1	Spring (top)
3	40X2036	1	1	Deflector gate (top)
4	40X4772	1	1	Static brush mylar assembly
5	40X2037	1	1	Deflector gate
6	40X2065	1	1	Spring
7	40X3242	1	1	Sensor (pass through)
8	40X2061	5	1	Deflector gate solenoid
9	40X4369	1	1	Sensor (deflector gate HP)
10	40X3240	1	1	Sensor (media bin empty)
11	40X2038	1	1	Media bin full actuator
12	40X5718	1	1	5 bin mailbox controller card assembly

# Assembly 19: High capacity stacker

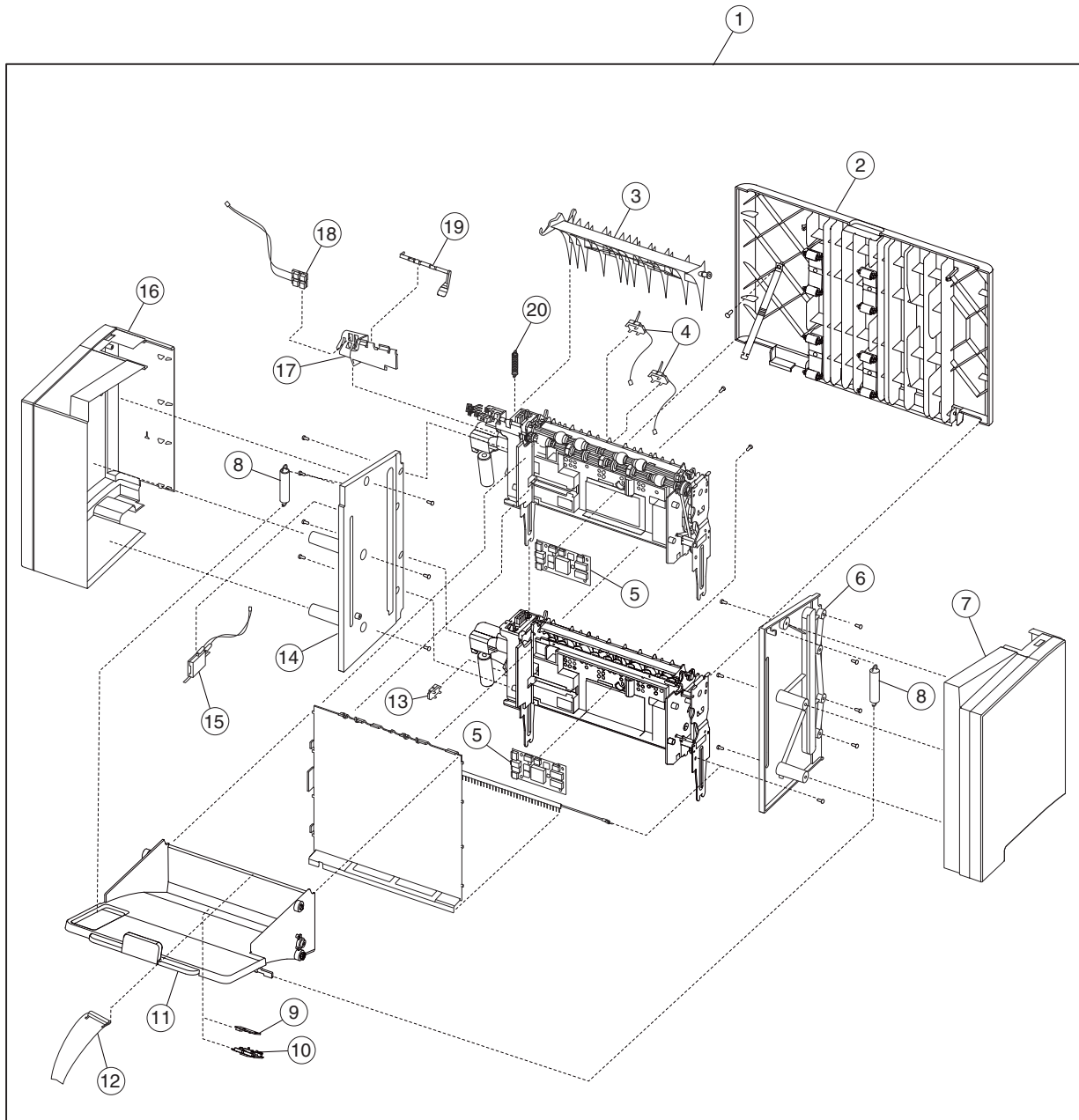

## Assembly 19: High capacity stacker

Asm-Index	Part number	Units/mach	Units/kit or pkg	Description
1	40X5730	1	1	Complete high capacity stacker assembly
2	40X5737	1	1	Rear door assembly
3	40X1988	1	1	Deflector gate
4	40X3264	2	1	Sensor (pass through)
5	40X5733	1	1	High capacity output controller card assembly
6	40X5734	1	1	Right frame
7	40X5735	1	1	Right cover
8	56P4210	1	2	Media output bin recoil spring
9	40X4773	1	1	Standard output bin LED
10	40X5755	1	1	LED clear lens
11	40X5731	1	1	Media output bin assembly
12	40X1998	1	1	Media bail assembly
13	40X4369	1	1	Sensor (deflector gate HP)
14	40X5748	1	1	Left frame
15	56P4208	1	1	Switch (media bin HP)
16	40X5736	1	1	Left cover
17	40X1989	1	1	Sensor bracket
18	40X3265	1	1	Sensor (media bin full assembly)
19	56P4212	1	1	Media bin full actuator
20	40X0028	1	1	Spring (top)

## Assembly 20: Output expander

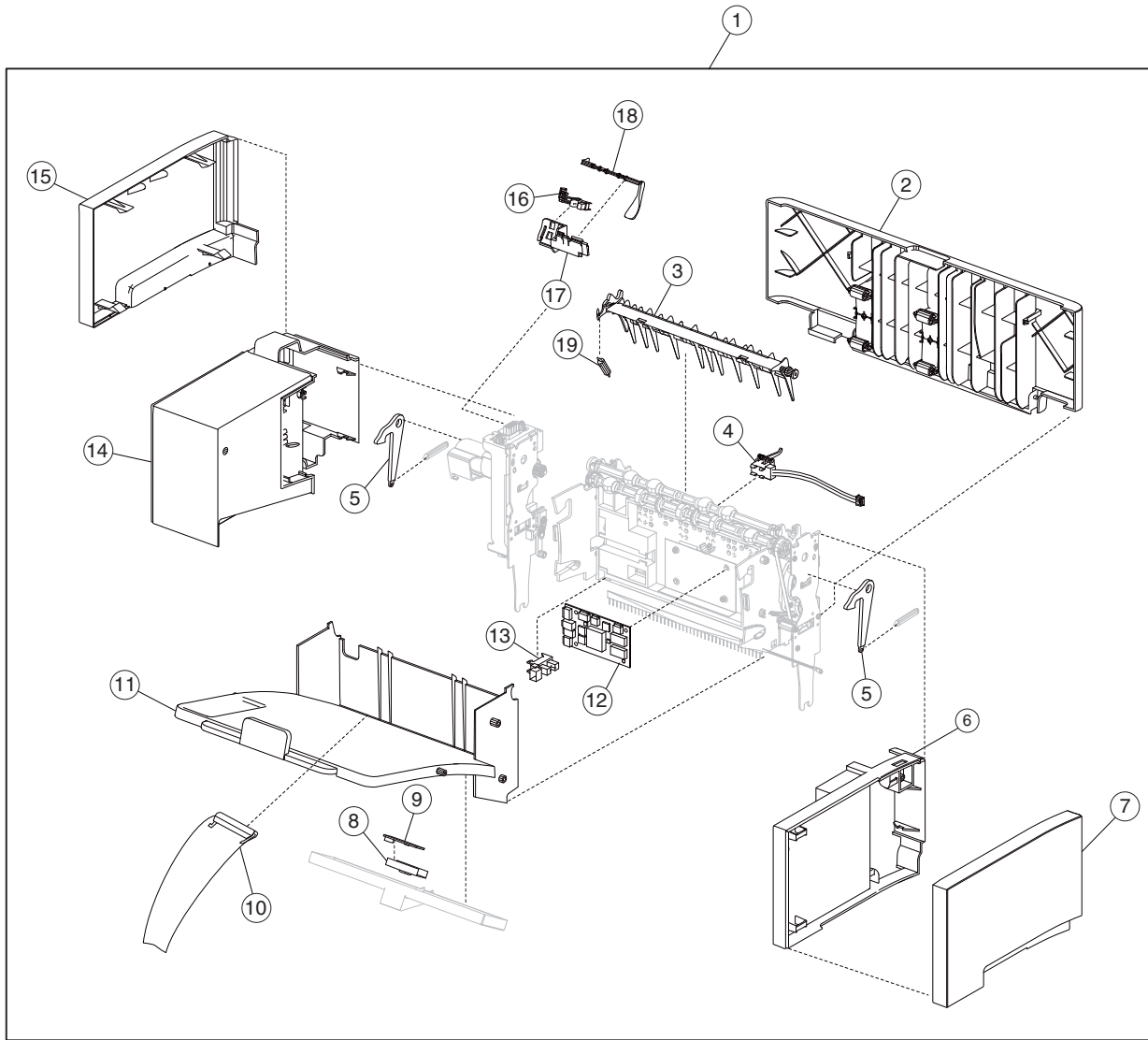



## Assembly 20: Output expander

Asm-Index	Part number	Units/mach	Units/kit or pkg	Description
1	40X5719	1	1	Complete output expander assembly
2	40X5722	1	1	Rear door assembly
3	40X1988	1	1	Deflector gate
4	40X3264	1	1	Sensor (pass through)
5	40X1991	2	1	Output expander media bin latch
6	40X5726	1	1	Right inner cover
7	40X5725	1	1	Right outer cover
8	40X5755	1	1	LED clear lens
9	40X4773	1	1	Standard output bin LED
10	40X1998	1	1	Media bail assembly
11	40X5721	1	1	Media output bin assembly
12	40X5747	1	1	Output expander controller card
13	40X4369	1	1	Sensor (deflector gate HP)
14	40X5724	1	1	Left inner cover
15	40X5723	1	1	Left Outer cover
16	40X3265	1	1	Sensor (media bin full)
17	40X1989	1	1	Sensor bracket
18	40X1990	1	1	Media bin full actuator
19	40X0028	1	1	Spring (top)

## Assembly 21: Envelope feeder and external duplex

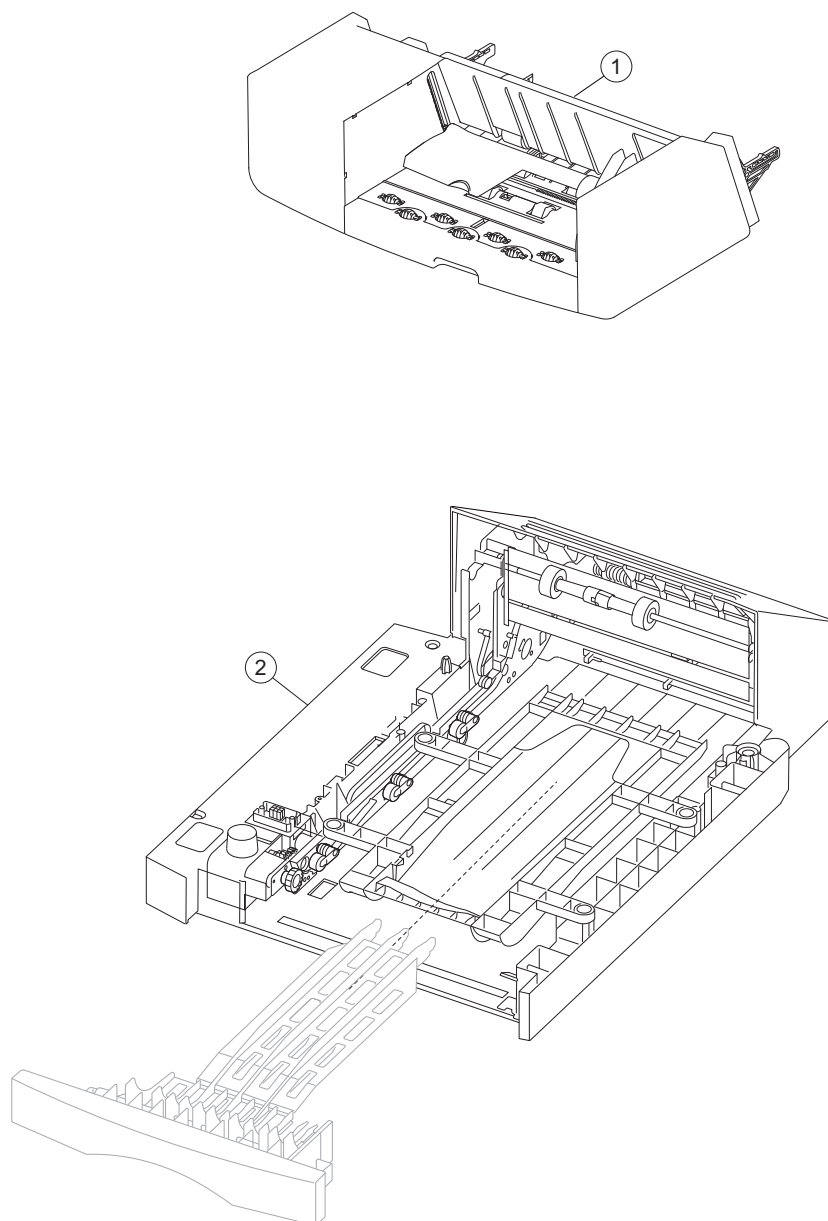

**Assembly 21: Envelope feeder and external duplex**

<b>Asm-Index</b>	<b>Part number</b>	<b>Units/mach</b>	<b>Units/kit or pkg</b>	<b>Description</b>
1	40X5739	1	1	Envelope feeder (T650, T652, and T654 only - will not fit the T656)
2	40X5904	1	1	External duplex

## Assembly 22: RFID UHF Option assembly

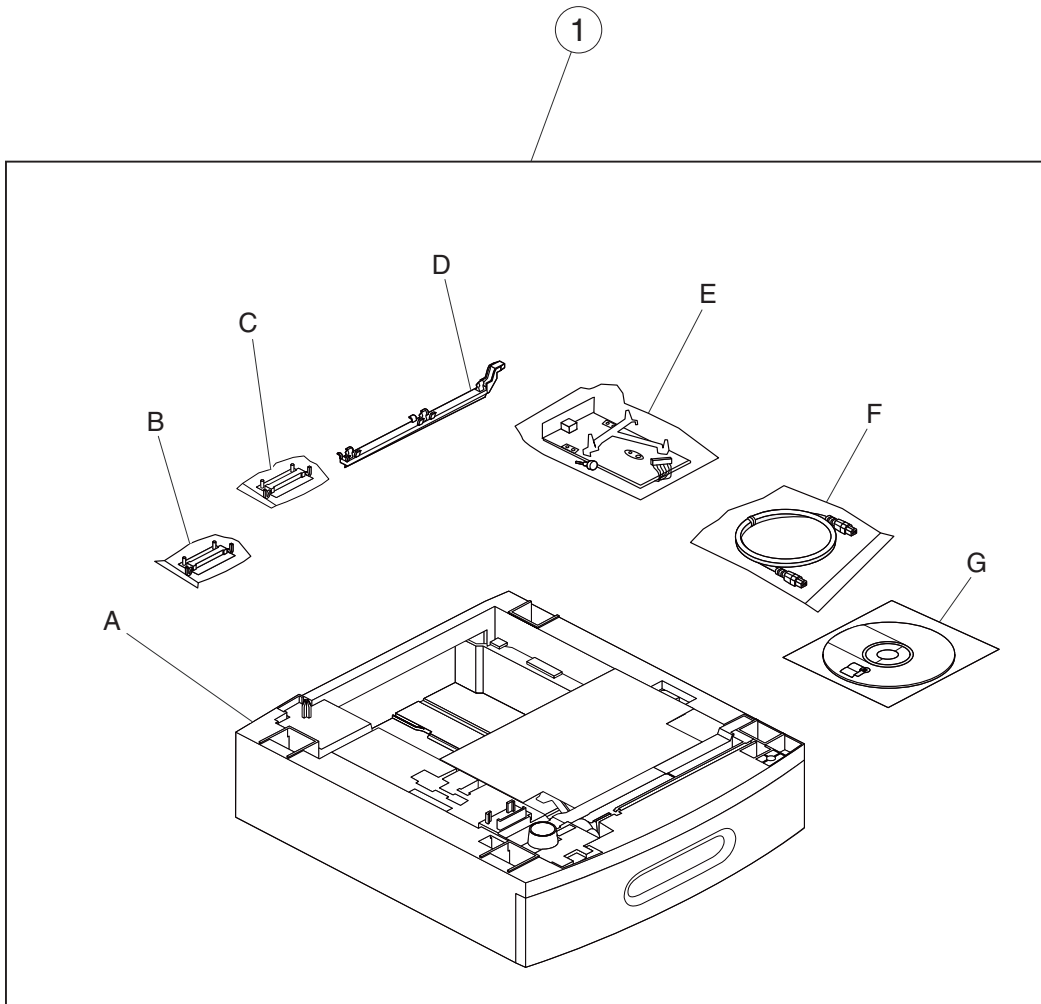

Asm-Index	Part number	Units/mach	Units/kit or pkg	Description
1	40X1483	1	1	US RFID UHF option assembly including: A. RFID UHF option B. Firmware card C. User flash card D. Fuser wiper E. Interface card, plastic tee, screw F. RFID cable G. Documentation CD
1	40X1484	1	1	EU RFID UHF option assembly including: A. RFID UHF option B. Firmware card C. User flash card D. Fuser wiper E. Interface card, plastic tee, screw F. RFID cable G. Documentation CD

## Assembly 23: Miscellaneous

Asm-Index	Part number	Units/mach	Units/kit or pkg	Description
NS	40X5903	1	1	Relocation kit
NS	40X4723	1	1	Printer maintenance kit (100 V type 1 fuser)
NS	40X4724	1	1	Printer maintenance kit (110 V type 1 fuser)
NS	40X4765	1	1	Printer maintenance kit (220 V type 1 fuser)
NS	40X4766	1	1	Printer maintenance kit (100 V type 2 fuser)
NS	40X4767	1	1	Printer maintenance kit (110 V type 2 fuser)
NS	40X4768	1	1	Printer maintenance kit (220 V type 2 fuser)
NS	40X5937	1	1	128MB DIMM, DDR1, for T650 and T652
NS	40X5938	1	1	256MB DIMM, DDR1, for T650 and T652
NS	40X5939	1	1	512MB DIMM, DDR1, for T650 and T652
NS	40X5301	1	1	256 MB SO-DIMM, DDR2 for T654
NS	40X5302	1	1	12MB SO-DIMM, DDR2 for T654
NS	40X5303	1	1	1GB (1024MB) SO-DIMM, DDR2 for T654
NS	40X5704	1	1	256MB user flash memory card for T65X
NS	40X4822	1	1	Hard disk drive for T65X
NS	40X5057	1	1	TAA hard drive assembly with connector
NS	40X7029	1	1	T650/T652 Card for PRESCRIBE Emulation
NS	40X7030	1	1	T654 Card for PRESCRIBE Emulation
NS	40X2863	1	1	T656 Card for PRESCRIBE Emulation
NS	40X5952	1	1	Lexmark PrintCryption card
NS	40X5955	1	1	T650/T652 Forms and Bar code card
NS	40X5956	1	1	T650/T652 Card for IPDS and SCS/TNe
NS	40X5962	1	1	T650/T652 KS emulation card
NS	40X5954	1	1	T654/T656 Forms and Bar code card
NS	40X5957	1	1	T654 card for IPDS and SCS/TNe
NS	40X2862	1	1	T656 card for IPDS and SCS/TNe
NS	40X5969	1	1	Korean font card
NS	40X5970	1	1	Simplified Chinese font card
NS	40X5971	1	1	Traditional Chinese font card
NS	40X5972	1	1	Japanese font card
NS	40X1556	1	1	Parts pack, ISP thumbscrew and standoff
NS	40X5316	1	1	ISP interface cable assembly
NS	40X4826	1	1	MarkNet N8120 gigabit ethernet print server
NS	40X4827	1	1	MarkNet N8130 fiber ethernet print server
NS	40X5038	1	1	MarkNet N8150 802.11n wireless print server (US/Americas)
NS	40X5039	1	1	MarkNet N8150 802.11n wireless print server (WW, except US/Americas)
NS	56P2129	1	1	Lexmark N4000e print server
NS	56P2744	1	1	Lexmark N4050e (1 port USB) wireless 802.11g (US/Americas)
NS	40X1593	1	1	MarkNet N7000e Fast Ethernet 10/100BaseTX-USB
NS	40X1594	1	1	MarkNet N7002e Fast Ethernet 10/100BaseTX - Parallel
NS	40X1592	1	1	Lexmark MarkNet N7020e (4 port USB) ethernet 10base T/100Base TX/1000BaseT
NS	40X4819	1	1	RS-232C serial interface card

<b>Asm-Index</b>	<b>Part number</b>	<b>Units/mach</b>	<b>Units/kit or pkg</b>	<b>Description</b>
NS	40X4823	1	1	Parallel 1284-B interface card
NS	40X1367	1	1	10-Foot parallel printer cable
NS	40X2665	1	1	Fuser oil wiper (black housing)
NS	40X2666	1	1	Fuser wax wiper (gray housing)
NS	40X1368	1	1	2-Meter USB printer cable
NS	40X1462	1	1	Locking universal media drawer with tray, 200 sheet
NS	40X1463	1	1	Locking media drawer with tray, 550 sheet
NS	40X1464	1	1	Locking universal media drawer with tray, 400 sheet

## Assembly 24: Power cords

Asm-Index	Part number	Units/mach	Units/kit or pkg	Description
NS	40X0269	1	1	Power cord LV, USA & Canada, Latin America
NS	40X0288	1	1	Power cord HV, Argentina
NS	40X1766	1	1	Power cord HV, Bolivia & Peru
NS	40X0273	1	1	Power cord HV, Chile, Uruguay
NS	40X3141	1	1	Power cord HV, Paraguay, Austria, Belgium, France, Germany, Italy, Netherlands, Bluemark, Czech & Solvic countries, Greece, Hungary, Medmark 1, Medmark 2, Arabic, Poland, Russia, CIS, Spain, Portugal, & Ireland
NS	40X4596	1	1	Power cord LV, Brazil PPB kits
NS	40X0271	1	1	Power cord HV, Asian, Brunei, Cambodia, Indonesia, Laos, Malaysia, Myanmar, Philippines, Singapore, Thailand, Vietnam, Afghanistan, Bangladesh, Bhutan, India, Nepal, Pakistan, Sri Lanka, Tibet, & Hong Kong
NS	40X0301	1	1	Power cord HV, Australia & New Zealand
NS	40X3609	1	1	Power cord 100 V, Japan
NS	40X1792	1	1	Power cord, HV, Korea
NS	40X0303	1	1	Power cord, HV PRC
NS	40X1791	1	1	Power cord LV, Taiwan
NS	40X1774	1	1	Power cord HV, Denmark, Finland, Norway, Sweden
NS	40X0275	1	1	Power cord, HV, Israel
NS	40X1773	1	1	Power cord HV, South Africa, Namibia, Lesotho, Botswana & Pakistan
NS	40X1772	1	1	Power cord HV, Switzerland

## Assembly 25: Universal trays and accessories

Asm-Index	Part number	Units/mach	Units/kit or pkg	Description
NS	40X5857	1	1	Universal media drawer with tray, 200 sheet
NS	40X5858	1	1	Universal media tray, 200 sheet
NS	40X5859	1	1	Universal media drawer with tray, 400 sheet
NS	40X5860	1	1	Universal media tray, 400 sheet
NS	40X5945	1	1	33" banner drawer with tray
NS	40X5946	1	1	33" banner tray
NS	40X5947	1	1	48" banner drawer with tray
NS	40X7007	1	1	48" banner tray
NS	40X5863	1	1	Adjustable label stacking device
NS	40X5861	1	1	Kiosk presenter
NS	40X7001	1	1	Wear strips, smooth 250 sheet
NS	40X7002	1	1	Wear strips, dimpled 250 sheet
NS	99A1206	1	1	Wear strips, 3 row dimpled 250 sheet
NS	40X2786	1	1	Wear strips, 4 row dimpled 250 sheet
NS	40X7003	1	1	Wear strips, 3 row dimpled 550 sheet
NS	40X7004	1	1	Wear strips, dinky 550 sheet
NS	40X2787	1	1	Wear strips, 3 row dimpled 550 sheet
NS	40X2788	1	1	Wear strips, 4 row dimpled 550 sheet
NS	40X7009	1	1	250 sheet tray replacement wear strip kit
NS	40X7010	1	1	550 sheet tray replacement wear strip kit



# Index

## Numerics

5-bin mailbox  
output sensor test **3-18**

## A

acronyms **1-9, 3-89**  
adjustments  
fuser solenoid **4-6**  
gap adjustment **4-6**

## B

Button Test **3-8, 3-36**  
buttons  
accessing service menus **3-2, 3-30**  
Button Test **3-8, 3-36**

## C

Clear Custom Status **3-58**  
code update **3-2**  
Configuration ID **3-20, 3-45**  
configuration menu  
accessing **3-2, 3-25, 3-30, 3-49**  
available menus **3-25, 3-49**  
Demo Mode **3-27**  
Disk Encryption **3-56**  
Energy Conserve **3-28, 3-54**  
Env Prompts **3-28**  
Envelope Prompts **3-55**  
Factory Defaults **3-28, 3-54**  
Font Sharpening **3-57**  
Jobs On Disk **3-55**  
Key Repeat Initial Delay **3-58**  
Key Repeat Rate **3-58**  
LES Applications **3-58**  
Maint Cnt Value **3-25**  
Maintenance Page Count **3-49**  
Panel Menus **3-27, 3-52**  
Paper Prompts **3-28, 3-55**  
PPDS Emulation **3-27, 3-52**  
Print Quality Pages **3-51**  
Prt Quality Pgs **3-26**  
Require Standby **3-57**  
Reset Maint Cnt **3-26**  
Reset Maintenance Counter **3-50**  
SIZE SENSING **3-27, 3-52**  
Wipe Disk **3-57**  
Wiper Message **3-58**

covers  
parts catalog **7-2**

## D

defaults  
EP defaults **3-21, 3-46**  
factory defaults **3-28, 3-54**  
US/Non-US defaults **3-19, 3-44**

diagnostic information  
confirm the installation status **2-2**  
Power-on Reset sequence **2-2**  
diagnostics  
error code table **2-14**  
diagnostics menu  
accessing **3-30**  
available tests **3-31**  
BASE SENSOR TEST **3-42**  
DEVICE TESTS  
Disk Test/Clean **3-43**  
Quick Disk Test **3-43**  
DUPLEX TESTS  
Duplex Feed 1 **3-40**  
Duplex Feed 2 **3-40**  
Motor Test **3-39**  
Quick Test **3-38**  
Sensor Test **3-39**  
Top Margin **3-38, 3-39**  
EP SETUP  
Charge Roll **3-46**  
EP Defaults **3-46**  
Fuser Page Count **3-46**  
Fuser Temp **3-46**  
Gap Adjust **3-47**  
Print Contrast **3-46**  
Transfer **3-46**  
Warm Up Time **3-46**  
EVENT LOG  
Clear Log **3-48**  
Display Log **3-47**  
Print Log **3-48**  
exiting **3-33**  
HARDWARE TESTS  
Button Test **3-36**  
DRAM Test **3-37**  
Panel Test **3-36**  
INPUT TRAY TESTS  
Feed Test **3-40**  
Sensor Test **3-41**  
OUTPUT BIN TESTS  
Feed Test **3-41**  
Sensor Tests **3-41**  
PRINT TESTS  
input source **3-35**  
Prt Quality Pgs **3-35**  
PRINTER SETUP  
Configuration ID **3-45**  
Defaults **3-44**  
Edge to Edge **3-45**  
engine settings **3-44**  
Model Name **3-44**  
Page Count **3-44**  
Perm Page Count **3-44**  
Serial Number **3-44**

REGISTRATION **3-33**  
 Quick Test **3-34**  
 diagnostics mode **3-3**  
 accessing **3-2**  
 available tests **3-3**  
 BASE SENSOR TEST **3-19**  
 DUPLEX TESTS  
 Duplex Feed 1 **3-14**  
 Duplex Feed 2 **3-14**  
 Motor Test **3-14**  
 Quick Test **3-12**  
 Sensor Test **3-13**  
 Top Margin **3-13**  
 EP SETUP  
 Auto Dark Adj **3-22**  
 Charge Roll **3-22**  
 EP Defaults **3-21**  
 Fuser Page Count **3-21**  
 Fuser Temp **3-21**  
 Gap Adjust **3-22**  
 Print Contrast **3-22**  
 Transfer **3-21**  
 Warm Up Time **3-21**  
 EVENT LOG  
 Clear Log **3-24**  
 Display Log **3-23**  
 Print Log **3-23**  
 exiting **3-5**  
 FINISHER TESTS  
 Feed Test **3-18**  
 Sensor Test **3-18**  
 Staple Test **3-18**  
 HARDWARE TESTS  
 Button Test **3-8**  
 DRAM Test **3-8**  
 Panel Test **3-8**  
 INPUT TRAY TESTS  
 Feed Test **3-15**  
 Sensor Test **3-15**  
 OUTPUT BIN TESTS  
 Diverter Test **3-18**  
 Feed Test **3-15**  
 Feed to All Bins **3-16**  
 Sensor Tests **3-16**  
 PRINT TESTS  
 input source **3-7**  
 Prt Quality Pgs **3-7**  
 PRINTER SETUP  
 Configuration ID **3-20**  
 Defaults **3-19**  
 Edge to Edge **3-21**  
 engine settings **3-20**  
 Model Name **3-20**  
 Perm Page Count **3-20**  
 Printed Page Count **3-19**  
 Serial Number **3-20**  
 REGISTRATION **3-5**  
 Disk Encryption **3-56**  
 Diverter Test **3-18**

DRAM Test **3-8, 3-37**  
 Duplex **3-93**  
 duplex tests  
 Duplex Feed 1 **3-14, 3-40**  
 Duplex Feed 2 **3-14, 3-40**  
 Left Margin **3-39**  
 Motor Test **3-14, 3-39**  
 Quick Test **3-12, 3-38**  
 Sensor Test **3-13, 3-39**  
 Top Margin **3-13, 3-38**

## E

Edge to Edge **3-45**  
 Energy Conserve **3-54**  
 Engine Setting **3-44**  
 Envelope Prompts **3-55**  
 error codes  
 200.00 sensor (registration) late jam **2-129, 2-141, 2-142**  
 200.01 sensor (registration) lag jam **2-132**  
 ESD-sensitive parts **4-1**  
 event log  
 clear log (diagnostics menu) **3-48**  
 clear log (diagnostics mode) **3-24**  
 display log (diagnostics mode) **3-23, 3-47**  
 print log (diagnostics menu) **3-48**  
 print log (diagnostics mode) **3-23**

## F

finisher tests  
 Feed Tests **3-18**  
 Sensor Test **3-18**  
 Font Sharpening **3-57**  
 fuser solenoid  
 adjustment **4-6**

## G

gap adjustment **3-22, 3-47, 4-6**

## H

high-capacity output stacker  
 output sensor tests **3-17**

## I

image quality trouble **2-157**  
 blank print (no print) **2-160**  
 faint print (low contrast) **2-158**  
 image quality **2-158**  
 solid black **2-162**  
 troubleshooting **2-157**  
 vertical blank lines (white stripes in media transport direction) **2-163**  
 image quality troubles  
 after image **2-171**  
 background (fog) **2-172**  
 horizontal band printheads out **2-164**  
 horizontal stripes **2-166**  
 media damage **2-174**  
 no fuse **2-176**  
 partial lack **2-168**

- skew **2-173**
- spots **2-169**
- vertical stripes **2-165**
- input sensor tray tests **3-15, 3-41**
- input source tests **3-7, 3-35**
- input tray feed test **3-15, 3-40**

**J**

- Jobs On Disk **3-55**

**K**

- Key Repeat Initial Delay **3-58**
- Key Repeat Rate **3-58**

**L**

- Left Margin
  - duplex **3-39**
- LES Applications **3-58**
- Lexmark Embedded Solution **3-58**
- lithium battery **ii-xxi, 4-76**
- lubrication specifications **6-1**

**M**

- maintenance
  - ESD-sensitive parts **4-1**
  - lubrication **6-1**
  - maintenance kit **6-2**
  - safety inspection guide **6-1**
- maintenance approach **1-1**
- menus
  - accessing service menus **3-2, 3-30**
  - configuration menu **3-49**
  - diagnostics menu **3-31**
- Model Name **3-20, 3-44**

**O**

- operator panel
  - Button Test **3-8, 3-36**
  - Panel Test **3-8, 3-36**
  - parts catalog **7-2**
- options and features
  - description **3-60**
- output bin sensor tests **3-41**
  - 5-bin mailbox **3-18**
  - high-capacity output stacker **3-17**
  - output expander **3-17**
  - standard bin **3-16**
- output expander
  - output sensor test **3-17**

**P**

- page count
  - Fuser Page Count **3-21, 3-46**
  - Page Count **3-44**
  - permanent page count **3-20, 3-44**
  - Printed Page Count **3-19**
- Panel Menus **3-52**
- Panel Test **3-8, 3-36**
- Paper Prompts **3-55**
- parts catalog
  - covers **7-2**

- PPDS Emulation **3-52**
- print quality pages **3-7, 3-26, 3-35, 3-51**
- print registration **3-5, 3-33**
- printer overview **3-60**
- printer theory **3-61**
  - control **3-77**
    - fuser control **3-77**
    - printhead control **3-77**
  - drive **3-75**
  - electrical components and controller **3-76**
  - exit **3-74**
  - functions of main components **3-62**
    - media tray assembly **3-62, 3-90**
    - rear media guide **3-62, 3-90**
  - media tray assembly **3-63, 3-91**
    - detection of media size **3-63, 3-91**
    - sensor (feed-out) **3-65**
    - sensor (media level) **3-65, 3-87, 3-92**
    - sensor (media out) **3-65, 3-87, 3-91**
    - switch (media size) **3-65, 3-87, 3-91**
  - multi-purpose feeder (MPF) **3-65**
    - MPF feed roll **3-65**
    - MPF pick solenoid **3-65**
    - sensor (MPF media out) **3-65**
    - sensor (MPF media width) **3-65**
  - printhead assembly **3-69**
    - front thermistor **3-73**
    - fuser exit sensor **3-73**
    - heat roll **3-73**
    - pressure belt **3-73**
    - thermostat **3-73**
  - registration **3-67**
    - sensor (registration) **3-67**
  - standard media exit roll assembly
    - sensor (standard bin full) **3-74**
  - transfer **3-68**
    - 2nd transfer roll assembly **3-68**
  - xerographic process during a print cycle **3-78**

**Q**

- quality pages **3-7, 3-26, 3-35, 3-51**
- Quick Disk Test **3-43**
- Quick Test **3-6, 3-12, 3-34, 3-38**

**R**

- REGISTRATION **3-5, 3-33**
- registration **3-5, 3-33**
- Require Standby **3-57**

**S**

- safety information **ii-xxi**
- safety inspection guide **6-1**
- scheduled maintenance **6-2**
- serial number **3-20, 3-44**
- Service checks **2-126**
- system code **3-2**

**T**

- tools **1-8, 3-88**
- Top Margin

## 4062-XXX

duplex **3-13, 3-38**  
simplex (front side) **3-5, 3-33**

## U

unique tools **1-8, 3-88**  
upper front cover  
parts catalog **7-2**  
USB speed **3-59**

## W

warm up time **3-21, 3-46**  
Wipe Disk **3-57**  
Wiper Message **3-58**

## Part number index

P/N	Description	Page
40X0028	Spring (top) -----	7-37, 7-39, 7-41
40X0269	Power cord LV, USA & Canada, Latin America -----	7-47
40X0271	Power cord HV, Asian, Brunei, Cambodia, Indonesia, Laos, Malaysia, Myanmar, Philippines, Singapore, Thailand, Vietnam, Afghanistan, Bangladesh, Bhutan, India, Nepal, Pakistan, Sri Lanka, Tibet, & Hong Kong - 7-47	7-47
40X0273	Power cord HV, Chile, Uruguay -----	7-47
40X0275	Power cord, HV, Israel -----	7-47
40X0288	Power cord HV, Argentina -----	7-47
40X0301	Power cord HV, Australia & New Zealand -----	7-47
40X0303	Power cord, HV PRC -----	7-47
40X1367	10-Foot parallel printer cable -----	7-46
40X1368	2-Meter USB printer cable -----	7-46
40X1385	Operator panel door assembly (T656) -----	7-7
40X1462	Locking universal media drawer with tray, 200 sheet -----	7-46
40X1463	Locking media drawer with tray, 550 sheet -----	7-46
40X1464	Locking universal media drawer with tray, 400 sheet -----	7-46
40X1483	US RFID UHF option assembly -----	7-44
40X1484	EU RFID UHF option assembly -----	7-44
40X1556	Parts pack, ISP thumbscrew and standoff -----	7-45
40X1592	Lexmark MarkNet N7020e (4 port USB) ethernet 10base T/100Base TX/1000BaseT -----	7-45
40X1593	Lexmark MarkNet N7002e (1 port parallel) ethernet 10baseT/100BaseTX -----	7-45
40X1594	Lexmark MarkNet N7002e (1 port parallel) ethernet 10base T/100Base TX -----	7-45
40X1766	Power cord HV, Bolivia & Peru -----	7-47
40X1772	Power cord HV, Switzerland -----	7-47
40X1773	Power cord HV, South Africa, Namibia, Lesotho, Botswana & Pakistan -----	7-47
40X1774	Power cord HV, Denmark, Finland, Norway, Sweden -----	7-47
40X1791	Power cord LV, Taiwan -----	7-47
40X1792	Power cord, HV, Korea -----	7-47
40X1862	Side cover, right (T652) -----	7-3
40X1863	250 Option drive shaft with spring -----	7-21
40X1863	Option drive shaft with spring (T650) -----	7-9
40X1864	Print cartridge ID connector assembly -----	7-13
40X1865	Printhead cable (T652, T654, and T656) -----	7-13
40X1866	Sensor shield assembly -----	7-17
40X1868	Print cartridge clamp assembly -----	7-11
40X1869	Transfer deflector with static brush -----	7-11
40X1870	100 V type 1 fuser assembly -----	7-17
40X1871	220 V type 1 fuser assembly -----	7-17
40X1876	MPF gear shield -----	7-15
40X1883	MPF pick roll assembly with flanges and clip -----	7-15
40X1884	MPF tray door assembly (T654) -----	7-15
40X1886	Transfer roll assembly with tool -----	7-13
40X1887	Transfer roll bracket with cable assembly, left -----	7-13
40X1888	Transfer roll bracket assembly, right -----	7-13
40X1889	Duplex deletion assembly (T652, T654) -----	7-11
40X1892	Charge roll arm assembly, left -----	7-13
40X1893	Charge roll arm assembly with cable, right -----	7-13
40X1900	Media turn guide with actuator -----	7-11
40X1971	Inner cover, left (T656) -----	7-7
40X1972	Inner cover, right (T656) -----	7-7
40X1973	Media support (T656) -----	7-3
40X1988	Deflector gate -----	7-39, 7-41
40X1989	Sensor bracket -----	7-39, 7-41
40X1990	Media bin full actuator -----	7-41

40X1991	Output expander media bin latch	7-41
40X1998	Media bail assembly	7-39, 7-41
40X2036	Deflector gate (top)	7-37
40X2037	Media bin 1st - 4th diverter	7-37
40X2038	Media bin full actuator	7-37
40X2045	Operator panel cable assembly (T656)	7-7
40X2051	USB cable assembly (T656)	7-7
40X2061	Deflector gate solenoid	7-37
40X2065	Spring	7-37
40X2077	Counterbalance spring (T656)	7-7
40X2078	Spring connector (T656)	7-7
40X2089	MPF tray door assembly (T656)	7-7
40X2665	Fuser oil wiper (black housing)	7-46
40X2666	Fuser wax wiper (gray housing)	7-46
40X2786	Wear strips, 4 row dimpled 250 sheet	7-48
40X2787	Wear strips, 3 row dimpled 550 sheet	7-48
40X2788	Wear strips, 4 row dimpled 550 sheet	7-48
40X2862	T656 card for IPDS and SCS/TNe	7-45
40X2863	T656 Card for PRESCRIBE Emulation	7-45
40X3141	Power cord HV, Paraguay, Austria, Belgium, France, Germany, Italy, Netherlands, Bluemark, Czech & Solvic countries, Greece, Hungary, Medmark 1, Medmark 2, Arabic, Poland, Russia, CIS, Spain, Portugal, & Ireland	7-47
40X3240	Sensor (media bin empty)	7-37
40X3242	Sensor (pass through)	7-37
40X3264	Sensor (pass through)	7-39, 7-41
40X3265	Sensor (media bin full assembly)	7-39
40X3265	Sensor (media bin full)	7-41
40X3447	250 Sheet pick arm bracket assembly	7-21
40X3448	250 Sheet bellcrank recoil spring	7-21
40X3449	Media tray assembly, 250 sheet	7-21
40X3453	250 Sheet option drawer assembly	7-21
40X3454	550 Sheet pick arm bracket assembly	7-23
40X3609	Power cord 100 V, Japan	7-47
40X3822	Media tray catch spring	7-21, 7-23
40X3854	Media size actuator	7-21, 7-23
40X3957	550 Sheet option drawer assembly	7-23
40X4302	Aligner assembly with ground strap and adj. screw (T650)	7-9
40X4303	Aligner assembly with ground strap and adj. screw (T652, T654, and T656)	7-9
40X4304	Pick arm assembly with spring, 250 sheet (T650)	7-15
40X4305	Pick arm assembly with spring, 500 sheet (T652, T654, and T656)	7-15
40X4306	Pick arm spring (T650)	7-15
40X4307	550 Sheet bellcrank recoil spring	7-23
40X4307	Pick arm spring (T652, T654, and T656)	7-15
40X4308	Pick roll assembly (2)	7-15, 7-21, 7-23, 7-25
40X4309	250 Sheet media out actuator	7-21
40X4309	250 Sheet media out actuator (T650)	7-15
40X4310	550 Sheet media out actuator	7-23, 7-25
40X4310	550 Sheet media out actuator (T652, T654, and T656)	7-15
40X4311	Media support (T650, T652)	7-3
40X4313	Pick arm sensor cable assembly	7-15
40X4314	Connection access cover, rear (T652, T654, and T656)	7-3
40X4316	Charge roll link spring, left	7-13
40X4317	Charge roll link spring, right	7-13
40X4318	Fuser access door assembly (T652, T654, and T656)	7-11
40X4319	Fuser access door assembly (T650)	7-11
40X4320	Laser cover assembly, 250 sheet output (T650 and T652)	7-3
40X4321	Laser cover assembly, 500 sheet output (T654)	7-3
40X4322	Inner cover, left (T650, T652, and T654)	7-3
40X4323	Side cover, left (T654)	7-3

40X4324	Side cover, left (T650) -----	7-3
40X4325	Side cover, left (T652) -----	7-3
40X4326	Output cover assembly -----	7-3
40X4329	Door assembly, rear (T652) -----	7-3
40X4330	Connection access cover, rear (T650) -----	7-3
40X4331	Door assembly, rear (T654 and T656) -----	7-3
40X4332	Door assembly, rear (T650) -----	7-3
40X4334	Cover assembly, rear lower (T652 and T654) -----	7-3
40X4335	Cover assembly, rear lower (T652, T654, and T656) -----	7-3
40X4336	Inner cover, right (T650, T652, and T654) -----	7-3
40X4337	Side cover, right (T654) -----	7-3
40X4338	Side cover, right (T650) -----	7-3
40X4339	Access door -----	7-3
40X4343	Redrive motor assembly (T652, T654, and T656) -----	7-9
40X4344	Duplex drive motor assembly (T652, T654, and T656) -----	7-9
40X4345	Duplex (input) sensor assembly (T652, T654, and T656) -----	7-9
40X4346	Duplex assembly with 2 belts and 2 pulleys (T652, T654, and T656) -----	7-9
40X4348	Duplex guide assembly, front (T652, T654, and T656) -----	7-9
40X4349	Duplex guide spring, right (T652, T654, and T656) -----	7-9
40X4350	Duplex drive belt, lower (T652, T654, and T656) -----	7-9
40X4351	Duplex guide handle (T652, T654, and T656) -----	7-9
40X4352	Duplex guide, rear (T652, T654, and T656) -----	7-9
40X4353	Duplex guide spring, rear (T652, T654, and T656) -----	7-9
40X4354	Duplex drive belt, upper (T652, T654, and T656) -----	7-9
40X4355	LVPS card assembly -----	7-17
40X4356	Duplex cooling fan -----	7-17
40X4357	Duplex cooling fan cable assembly -----	7-17
40X4358	Envelope / input option tray cable assembly -----	7-19
40X4359	Print cartridge cooling fan -----	7-17
40X4360	Print cartridge cooling fan cable assembly -----	7-17
40X4361	HVPS / sensor cable assembly -----	7-19
40X4362	HVPS card assembly -----	7-19
40X4363	Main cooling fan (T650) -----	7-13
40X4364	Main cooling fan (T652, T654, and T656) -----	7-13
40X4365	MPF pick solenoid assembly -----	7-15
40X4366	Operator panel cable assembly -----	7-5
40X4367	Printhead cable assembly (T650) -----	7-13
40X4368	Sensor (input) -----	7-19
40X4369	Sensor (deflector gate HP) -----	7-37, 7-39, 7-41
40X4369	Sensor (duplex input) (T652, T654, and T656) -----	7-9
40X4369	Sensor (media empty) -----	7-21, 7-23, 7-25
40X4369	Sensor (media low) -----	7-21, 7-23, 7-25
40X4369	Sensor (media stack) -----	7-31
40X4369	Sensor (paddle HP) -----	7-31
40X4369	Sensor (standard bin exit) -----	7-13
40X4369	Sensor (tamper HP left) -----	7-31
40X4369	Sensor (tamper HP right) -----	7-31
40X4370	Sensor (toner empty) -----	7-19
40X4372	Sensor (standard bin exit) actuator assembly -----	7-13
40X4375	System card assembly (T650) -----	7-19
40X4376	Output option interface cable assembly -----	7-19
40X4377	USB cable assembly -----	7-5
40X4378	Sensor (toner density) -----	7-17
40X4379	Toner density sensor cable assembly -----	7-17
40X4380	Counterbalance spring -----	7-5
40X4381	Drum grounding contact -----	7-19
40X4382	Print cartridge HV contact -----	7-19
40X4383	Cleaning blade contact -----	7-19
40X4384	EP cooling fan duct -----	7-11



40X4385	Envelope feeder interface cover	7-11
40X4386	Fuser drive release linkage	7-9
40X4387	Inner deflector (T650)	7-11
40X4388	Inner deflector (T652, T654, and T656)	7-11
40X4389	LVPS cooling duct	7-11
40X4390	Machine pad	7-11
40X4391	Main cooling duct (T650)	7-11
40X4392	Main cooling duct (T652, T654, and T656)	7-11
40X4394	Tray catch spring	7-15
40X4395	Media tray roller catch assembly	7-21, 7-23
40X4395	Tray roller catch assembly	7-15
40X4396	Operator panel hinge assembly, left	7-5
40X4397	Operator panel hinge assembly, right	7-5
40X4406	Print cartridge support roller	7-11
40X4415	LCD screen bezel (T650n)	7-5
40X4417	Fuser wiper cover assembly	7-3
40X4418	110 V type 1 fuser assembly	7-17
40X4419	Fuser interface cable assembly	7-17
40X4457	MPF cam gear	7-15
40X4458	MPF lift plate assembly (T650)	7-15
40X4459	MPF lift plate assembly (T652, T654, and T656)	7-15
40X4460	MPF tray door assembly (T650)	7-15
40X4461	MPF tray door assembly (T652)	7-15
40X4462	Operator panel door assembly	7-5
40X4463	Printhead with cable assembly (T650)	7-13
40X4464	Printhead with cable assembly (T652 and T654)	7-13
40X4465	Redrive assembly (T650)	7-9
40X4466	Redrive assembly (T652)	7-9
40X4467	Redrive assembly (T654 and T656)	7-9
40X4468	Media tray assembly, 250 sheet	7-15
40X4469	Media tray assembly, 550 sheet	7-15, 7-23
40X4470	Output bail	7-3
40X4471	LCD screen bezel (T652dn)	7-5
40X4472	Switch (media size) assembly	7-15
40X4473	550 Option drive shaft with spring	7-23
40X4473	Option drive shaft with spring (T652, T654, and T656)	7-9
40X4474	System card assembly (T652)	7-19
40X4494	LCD screen bezel (T652n)	7-5
40X4569	Complete 250 sheet option tray assembly	7-21
40X4570	Anti-tip latch assembly	7-21, 7-23, 7-25
40X4571	Upper interface cable assembly	7-21, 7-23
40X4572	Lower interface cable assembly	7-21, 7-23
40X4574	250 Sheet controller card assembly	7-21
40X4575	Sensor (pass through) with cable	7-21, 7-23
40X4576	Complete 550 sheet option tray assembly	7-23
40X4578	550 Sheet controller card assembly	7-23
40X4579	Complete HCIT option tray assembly	7-25
40X4580	HCIT media tray assembly	7-25
40X4581	HCIT cover, rear	7-25
40X4582	HCIT cover, right	7-25
40X4583	HCIT cover, left	7-25
40X4584	HCIT tray cover, front	7-25
40X4585	HCIT tray closed latch with spring	7-25
40X4586	HCIT tray lift drive motor assembly	7-25
40X4587	HCIT media size actuator assembly	7-25
40X4588	Sensor (HCIT tray raised HP) with cable assembly	7-25
40X4589	Sensor (HCIT pass through) with cable	7-25
40X4590	HCIT pick arm bracket assembly	7-25
40X4591	HCIT bellcrank recoil spring	7-25



40X4592	HCIT controller card assembly	7-25
40X4593	HCIT drawer slide assembly	7-25
40X4594	HCIT interface cable assembly	7-25
40X4595	Pick arm sensor cable assembly	7-25
40X4596	Power cord LV, Brazil PPB kits	7-47
40X4602	Card reader assembly (3121 contact) (T656)	7-7
40X4603	Card reader assembly (5121 contact/RFID) (T656)	7-7
40X4604	Card reader assembly (5125 contact/HID) (T656)	7-7
40X4609	Left cover	7-29
40X4610	Right cover	7-29
40X4611	Top cover	7-29
40X4612	Handle cover	7-29
40X4613	Rear door assembly	7-29
40X4615	Paddle drive motor	7-31
40X4616	Operator panel latch assembly	7-5
40X4617	Finisher bin spring	7-29
40X4618	Sensor (finisher bin media present)	7-29
40X4619	Media output bin extension	7-29
40X4621	Left tamper motor assembly	7-31
40X4622	Right tamper motor assembly	7-31
40X4623	Tamper drive belt	7-31
40X4624	Tamper recoil spring	7-31
40X4625	Stapler/stacker controller card assembly	7-29
40X4626	Sensor (bin full send)	7-29
40X4627	LCD screen bezel (T654dn)	7-5
40X4628	LCD screen bezel (T654n)	7-5
40X4629	Connection bezel assembly, rear (T652, T654, and T656)	7-3
40X4630	Connection bezel assembly, rear (T650)	7-3
40X4631	Operator panel door latch assembly (T656)	7-7
40X4641	Stapler assembly	7-33
40X4645	Media stack flap actuator	7-31
40X4646	Media stack flap	7-31
40X4697	Media support (T654)	7-3
40X4723	Printer maintenance kit (100 V type 1 fuser)	7-45
40X4724	Printer maintenance kit (110 V type 1 fuser)	7-45
40X4765	Printer maintenance kit (220 V type 1 fuser)	7-45
40X4766	Printer maintenance kit (100 V type 2 fuser)	7-45
40X4767	Printer maintenance kit (110 V type 2 fuser)	7-45
40X4768	Printer maintenance kit (220 V type 2 fuser)	7-45
40X4772	Static brush mylar assembly	7-37
40X4773	Standard output bin LED	7-35, 7-39, 7-41
40X4819	RS-232C serial interface card	7-45
40X4822	Hard disk drive for T65X	7-45
40X4823	Parallel 1284-B interface card	7-46
40X4826	MarkNet N8120 gigabit ethernet print server	7-45
40X4827	MarkNet N8130 fiber ethernet print server	7-45
40X5038	MarkNet N8150 802.11n wireless print server (US/Americas)	7-45
40X5039	MarkNet N8150 802.11n wireless print server (WW, except US/Americas)	7-45
40X5057	TAA hard drive assembly with connector	7-45
40X5301	256 MB SO-DIMM, DDR2 for T654	7-45
40X5302	12MB SO-DIMM, DDR2 for T654	7-45
40X5303	1GB (1024MB) SO-DIMM, DDR2 for T654	7-45
40X5316	ISP interface cable assembly	7-45
40X5541	Media output bin	7-29
40X5544	Sensor (bin full receive)	7-29
40X5545	Standard output bin LED	7-29
40X5547	SFP stapler assembly (comes completely assembled)	7-27
40X5550	Complete 5 bin mailbox unit assembly	7-35, 7-37
40X5551	Duplex guide spring, left (T652, T654, and T656)	7-9

40X5704	256MB user flash memory card for T65X	7-45
40X5708	Top cover	7-35
40X5709	Rear door assembly	7-35
40X5710	Left outer cover	7-35
40X5711	Left inner cover	7-35
40X5712	Right outer cover	7-35
40X5713	Right inner cover	7-35
40X5714	Standard output bin LED bracket	7-35
40X5717	Output bin LED assembly	7-35
40X5718	5 bin mailbox controller card assembly	7-37
40X5719	Complete output expander assembly	7-41
40X5720	LED sensor cover	7-29
40X5721	Media output bin assembly	7-41
40X5722	Rear door assembly	7-41
40X5723	Left Outer cover	7-41
40X5724	Left inner cover	7-41
40X5725	Right outer cover	7-41
40X5726	Right inner cover	7-41
40X5727	LED clear lens	7-29
40X5729	Operator panel bezel, left (NON USB)	7-5
40X5730	Complete high capacity stacker assembly	7-39
40X5731	Media output bin assembly	7-39
40X5733	High capacity output controller card assembly	7-39
40X5734	Right frame	7-39
40X5735	Right cover	7-39
40X5736	Left cover	7-39
40X5737	Rear door assembly	7-39
40X5739	Envelope feeder (T650, T652, and T654 only - will not fit the T656dne)	7-43
40X5746	Operator panel bezel, left	7-5
40X5747	Output expander controller card	7-41
40X5748	Left frame	7-39
40X5749	Main drive motor assembly with option drive shaft	7-9
40X5753	Media bin extension assembly	7-35
40X5755	LED clear lens	7-35, 7-39, 7-41
40X5756	Output bin LED bracket	7-35
40X5852	Charge roll assembly with tool	7-13
40X5853	100 V type 2 fuser assembly	7-17
40X5854	110 V type 2 fuser assembly	7-17
40X5855	220 V type 2 fuser assembly	7-17
40X5857	Universal media drawer with tray, 200 sheet	7-48
40X5858	Universal media tray, 200 sheet	7-48
40X5859	Universal media drawer with tray, 400 sheet	7-48
40X5860	Universal media tray, 400 sheet	7-48
40X5861	Kiosk presenter	7-48
40X5863	Adjustable label stacking device	7-48
40X5903	Relocation kit	7-45
40X5904	External duplex	7-43
40X5906	Sensor (stapler pass through)	7-29
40X5909	Sensor (media in stapler)	7-33
40X5910	Stapler cover	7-29
40X5911	System card assembly (T654)	7-19
40X5937	128MB DIMM, DDR1, for T650 and T652	7-45
40X5938	256MB DIMM, DDR1, for T650 and T652	7-45
40X5939	512MB DIMM, DDR1, for T650 and T652	7-45
40X5945	33" banner drawer with tray	7-48
40X5946	33" banner tray	7-48
40X5947	48" banner drawer with tray	7-48
40X5952	Lexmark PrintCryption card	7-45
40X5954	T654/T656 Forms and Bar code card	7-45

40X5955	T650/T652 Forms and Bar code card	7-45
40X5956	T650/T652 Card for IPDS and SCS/TNe	7-45
40X5957	T654 card for IPDS and SCS/TNe	7-45
40X5962	T650/T652 KS emulation card	7-45
40X5969	Korean font card	7-45
40X5970	Simplified Chinese font card	7-45
40X5971	Traditional Chinese font card	7-45
40X5972	Japanese font card	7-45
40X7001	Wear strips, smooth 250 sheet	7-48
40X7002	Wear strips, dimpled 250 sheet	7-48
40X7003	Wear strips, 3 row dimpled 550 sheet	7-48
40X7004	Wear strips, dinky 550 sheet	7-48
40X7007	48" banner tray	7-48
40X7009	250 sheet tray replacement wear strip kit	7-48
40X7010	550 sheet tray replacement wear strip kit	7-48
40X7029	T650/T652 Card for PRESCRIBE Emulation	7-45
40X7030	T654 Card for PRESCRIBE Emulation	7-45
40X7031	Laser cover assembly, 500 sheet output (T656)	7-3
40X7032	Side cover, left (T656)	7-3
40X7033	Side cover, right (T656)	7-3
40X7034	Access cover (T656)	7-3
40X7035	Hard drive cooling fan (T656)	7-7
40X7036	System card assembly (T656DNE)	7-19
40X7037	Card reader cable assembly (T656)	7-7
40X7038	Operator panel bezel (T656)	7-7
40X7039	Card reader cable assembly (T656)	7-7
40X7040	Printhead with cable assembly (T656)	7-13
40X7042	Card reader mounting bracket (T656)	7-7
56P2129	Lexmark N4000e print server	7-45
56P2744	Lexmark N4050e (1 port USB) wireless 802.11g (US/Americas)	7-45
56P4191	Media bail assembly	7-35
56P4208	Switch (media bin HP)	7-39
56P4210	Media output bin recoil spring	7-39
56P4212	Media bin full actuator	7-39
99A0954	Bevel gear with grease packet and washer	7-9
99A1206	Wear strips, 3 row dimpled 250 sheet	7-48



# Print defects guide

Match a set of repeating defects on a print job to the marks on one of the vertical lines. The line that best matches the defects on the print job indicates which particular part may be causing the defect.

For example, the distance between these two marks represents a repeating defect that occurs every 28.3 mm (1.11 in.), which means the charge rollers may need to be replaced.

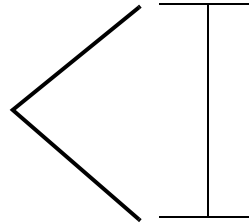

**Note:** If the defect appears on the printed side of a single-sided print job, replace the **toner cartridge** before replacing the **fuser**.

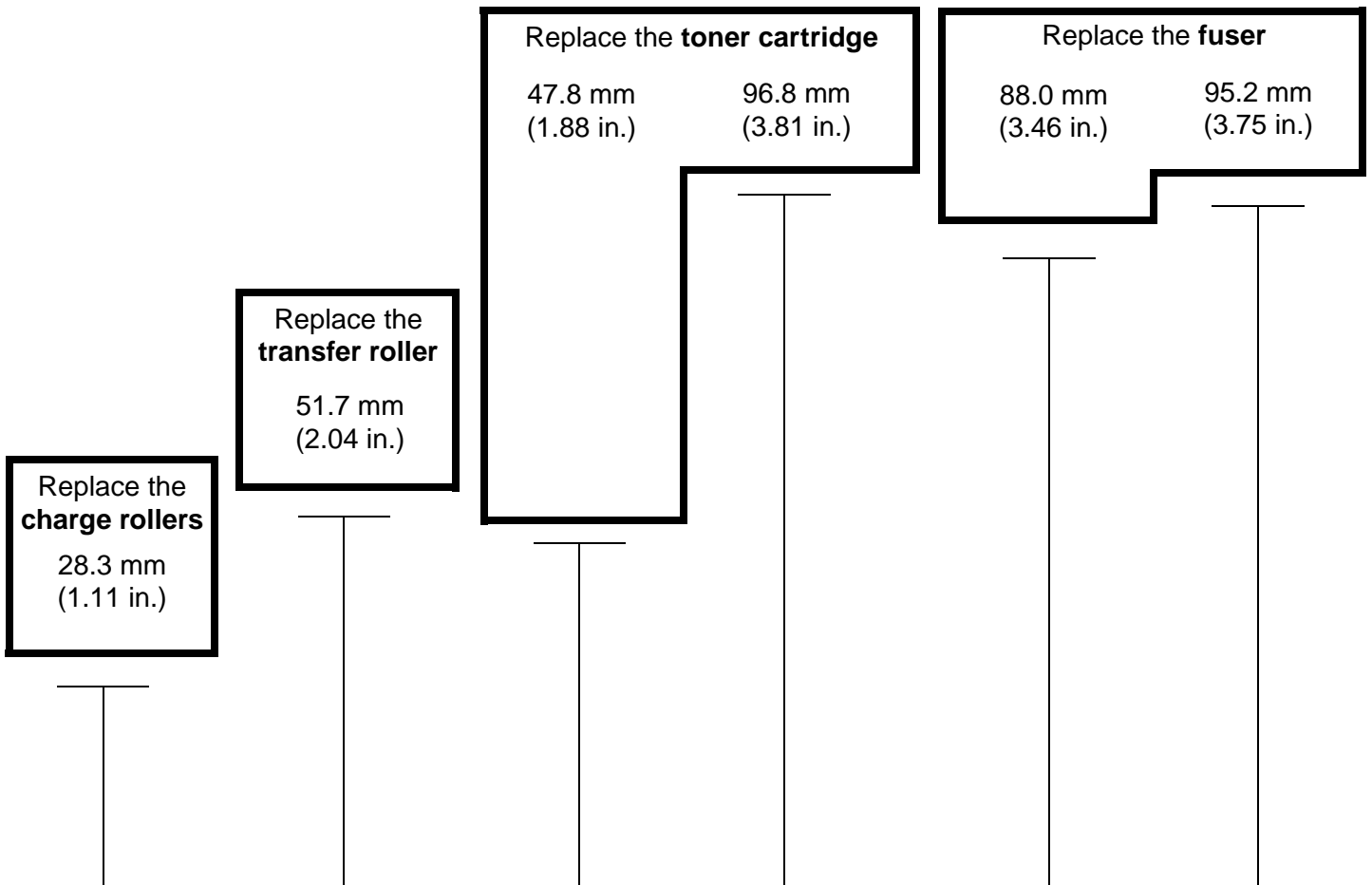

# 4062-T650 PRINTER

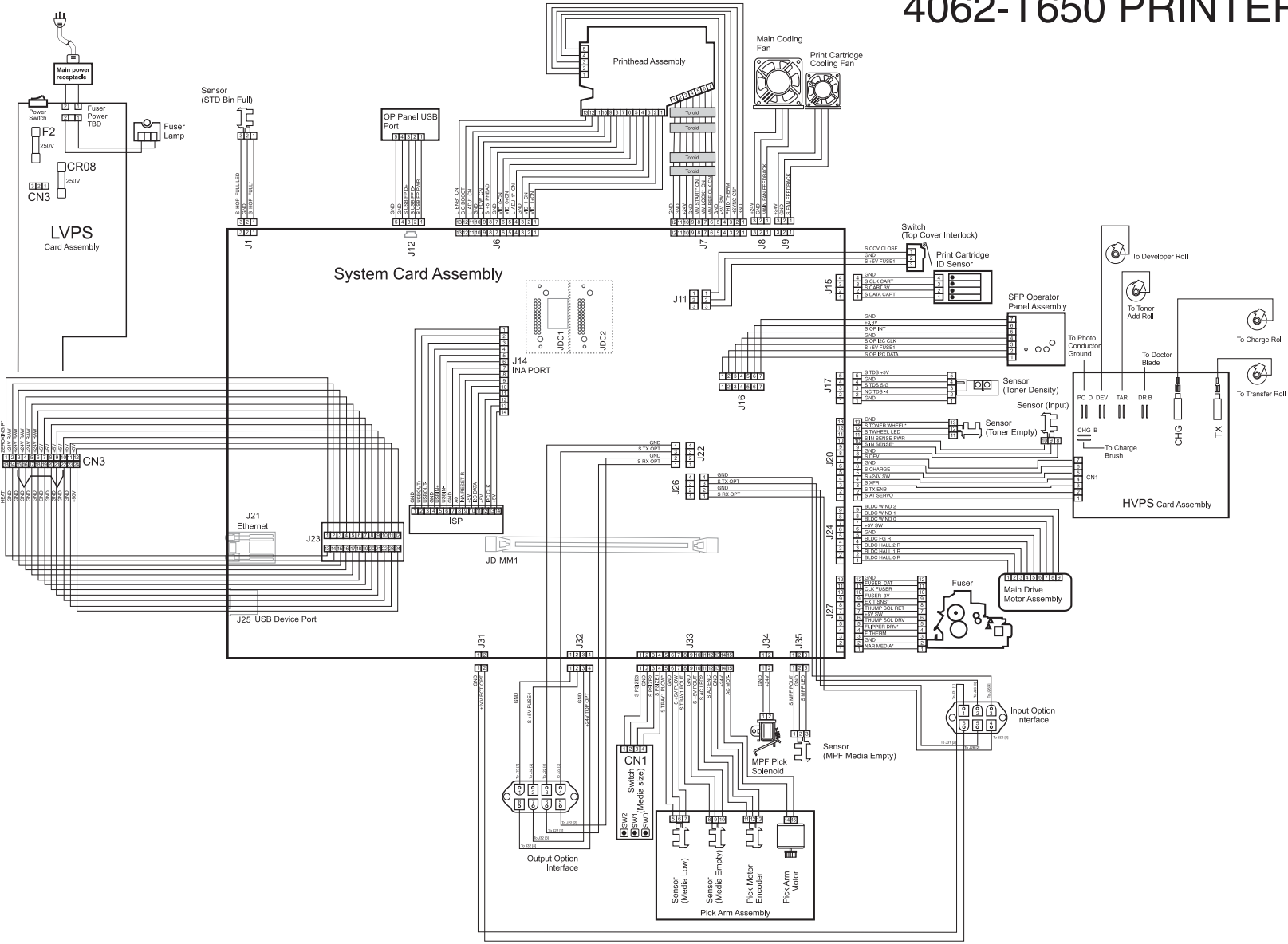

# 4062-T654 PRINTER

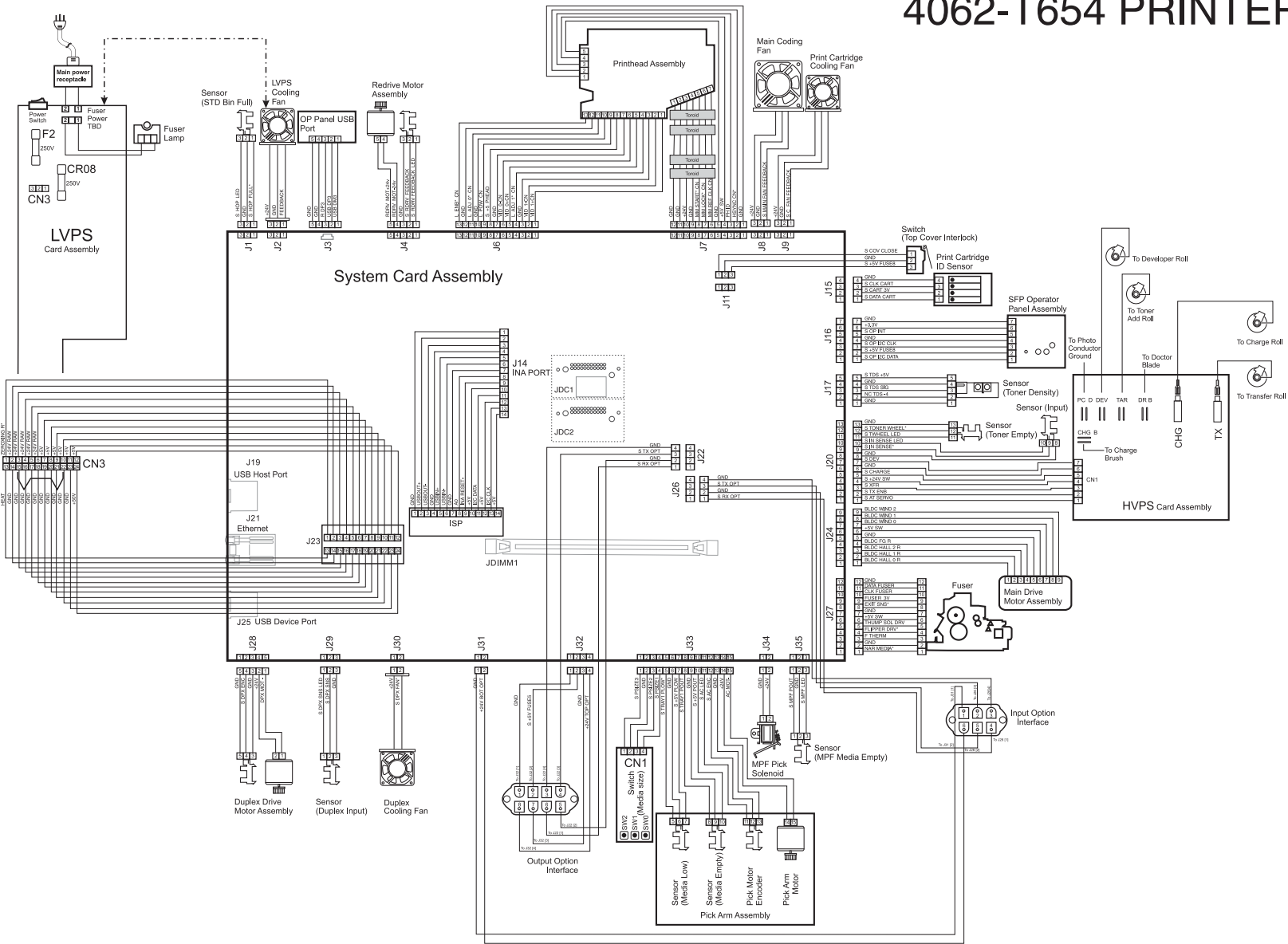

# 4062-T652 PRINTER

